

# Route 710 Tunnel Technical Feasibility Assessment Report

Task Order PS-4310-1268-05-01-2

*Submitted to:*



Los Angeles County Metropolitan Transportation Authority  
One Gateway Plaza  
Los Angeles, CA 90026  
MS 99-22-8

*Submitted by:*



June 7, 2006

**TABLE OF CONTENTS****TABLE OF CONTENTS**

<b>ES 1.0</b>	<b>Executive Summary .....</b>	<b>1</b>
<b>ES 1.1</b>	<b>Project Background .....</b>	<b>1</b>
<b>ES 1.2</b>	<b>Tunnel Technical Feasibility Assessment .....</b>	<b>1</b>
<b>ES 1.3</b>	<b>Tunnel Technical Feasibility Assessment – Findings .....</b>	<b>3</b>
<b>ES 1.4</b>	<b>Physical Feasibility.....</b>	<b>3</b>
ES 1.4.1	Tunneling Technologies.....	4
ES 1.4.2	Physical Characteristics .....	5
ES 1.4.3	Traffic Demand.....	5
<b>ES 1.5</b>	<b>Environmental/Social Feasibility.....</b>	<b>6</b>
<b>ES 1.6</b>	<b>Financial Feasibility.....</b>	<b>6</b>
<b>ES 1.7</b>	<b>Conclusion .....</b>	<b>6</b>
<b>1.0</b>	<b>Introduction.....</b>	<b>1</b>
<b>1.1</b>	<b>Project Background .....</b>	<b>1</b>
<b>1.2</b>	<b>Project History .....</b>	<b>1</b>
<b>1.3</b>	<b>MTA Team .....</b>	<b>3</b>
<b>1.4</b>	<b>MTA Tunnel Advisory Panel.....</b>	<b>3</b>
<b>1.5</b>	<b>MTA Working Group .....</b>	<b>3</b>
<b>1.6</b>	<b>Study Goals and Objectives .....</b>	<b>4</b>
<b>2.0</b>	<b>Summary of Large Highway Tunnels Domestic and International.....</b>	<b>5</b>
<b>2.1</b>	<b>A-86 Tunnel, Malmaison, France .....</b>	<b>6</b>
<b>2.2</b>	<b>M30 Project Madrid, Spain .....</b>	<b>8</b>
<b>2.3</b>	<b>Mt. Baker Ridge Tunnel, Seattle, Washington.....</b>	<b>9</b>
<b>3.0</b>	<b>Geotechnical Evaluation.....</b>	<b>13</b>
<b>3.1</b>	<b>Regional Geology and Tectonics.....</b>	<b>13</b>
<b>3.2</b>	<b>Site Geology .....</b>	<b>13</b>
<b>3.3</b>	<b>Stratigraphy and Structure.....</b>	<b>15</b>
3.3.1	Crystalline Basement Rock.....	15
3.3.2	Topanga Formation.....	15
3.3.3	Monterey/Puente Formation .....	21
3.3.4	Unnamed Shale .....	21
3.3.5	Fernando Formation.....	21
3.3.6	Quaternary Alluvium .....	21

<b>3.4</b>	<b>Faults</b> .....	<b>22</b>
3.4.1	Sierra Madre Fault .....	22
3.4.2	Santa Monica-Hollywood Fault System .....	22
3.4.3	Raymond Hill Fault.....	23
3.4.4	York Boulevard Fault .....	23
3.4.5	Eagle Rock Fault.....	23
<b>3.5</b>	<b>Local Seismicity</b> .....	<b>23</b>
<b>3.6</b>	<b>Structure Along Tunnel Study Alignment</b> .....	<b>24</b>
<b>3.7</b>	<b>Site Exploration and Testing in 2006</b> .....	<b>25</b>
3.7.1	Field Exploration for Feasibility Study.....	25
3.7.2	Testing.....	25
3.7.2.1	Soil Properties.....	26
3.7.2.2	Rock properties .....	26
<b>3.8</b>	<b>Groundwater</b> .....	<b>28</b>
<b>3.9</b>	<b>Subsurface Gas</b> .....	<b>29</b>
<b>3.10</b>	<b>Feasibility for Tunneling</b> .....	<b>29</b>
<b>3.11</b>	<b>Additional Exploration and Testing</b> .....	<b>30</b>
<b>4.0</b>	<b>Tunneling Technologies</b> .....	<b>31</b>
<b>4.1</b>	<b>Introduction</b> .....	<b>31</b>
<b>4.2</b>	<b>Tunnel Conditions and Requirements</b> .....	<b>31</b>
4.2.1	Horizontal Alignment and Controls.....	31
4.2.2	Vertical Alignment and Controls .....	31
4.2.3	Tunnel Cross Sectional Requirements .....	32
4.2.4	Cross-passages and Shafts .....	32
4.2.5	Geologic and Groundwater Conditions .....	32
<b>4.3</b>	<b>Tunneling Methods</b> .....	<b>33</b>
4.3.1	Tunnel Boring Machines.....	33
4.3.2	Sequential Excavation Methods.....	38
4.3.3	Fault Crossings.....	41
4.3.4	Underground Ventilation Buildings and Shafts .....	42
4.3.5	Hauling of Soil.....	42
4.3.6	Protection of Adjacent Structures .....	43
4.3.7	Instrumentation and Monitoring .....	44
4.3.8	Summary .....	44
<b>4.4</b>	<b>Tunnel Ventilation</b> .....	<b>45</b>
4.4.1	Ventilation System Types .....	45
4.4.2	Air Cleaning Technology.....	46
4.4.3	Tunnel Alternatives.....	47
4.4.4	Criteria .....	47
4.4.5	Analysis Approach.....	48

4.4.6	Analysis.....	49
4.4.7	Ventilation Installation.....	50
<b>5.0</b>	<b>Traffic Modeling / Traffic Analysis.....</b>	<b>52</b>
<b>5.1</b>	<b>Introduction.....</b>	<b>52</b>
<b>5.2</b>	<b>Scope and Limitations of the Traffic Analysis .....</b>	<b>52</b>
<b>5.3</b>	<b>Scenarios Analyzed .....</b>	<b>52</b>
<b>5.4</b>	<b>Route 710 Tunnel Traffic Volume Forecast .....</b>	<b>53</b>
5.4.1	2030 Average Daily Traffic (ADT) Volumes.....	53
5.4.2	2030 AM Peak Hour Traffic Volumes.....	53
5.4.3	2030 PM Peak Hour Traffic Volumes .....	55
<b>5.5</b>	<b>Gap-Closure Capacity Analysis.....</b>	<b>55</b>
<b>5.6</b>	<b>Comparison of Alternative Scenarios .....</b>	<b>55</b>
<b>5.7</b>	<b>Changes in Freeway and Arterial Street Traffic Volumes.....</b>	<b>60</b>
5.7.1	Freeway Traffic Volume Changes .....	60
5.7.2	Arterial Street Traffic Volume Changes .....	60
5.7.3	Arterial Streets Volume-to-Capacity Ratios .....	62
<b>5.8</b>	<b>Traffic Analysis Conclusions .....</b>	<b>66</b>
<b>6.0</b>	<b>Tunnel Configuration and Alignment.....</b>	<b>68</b>
<b>6.1</b>	<b>Introduction.....</b>	<b>68</b>
<b>6.2</b>	<b>Engineering Considerations.....</b>	<b>68</b>
6.2.1	Geotechnical .....	68
6.2.2	Traffic .....	69
6.2.3	Tunnel Construction Technology .....	69
<b>6.3</b>	<b>Tunnel Configuration .....</b>	<b>69</b>
6.3.1	Cross-section A1 .....	72
6.3.2	Cross-section A2.....	72
6.3.3	Cross-section A3.....	72
6.3.4	Cross-sections B1, B2, and B3 .....	73
6.3.5	Cross-sections C1, C2, and C3 .....	73
<b>6.4</b>	<b>Alignment.....</b>	<b>74</b>
6.4.1	Three Typical Alignments .....	74
6.4.2	Portal Locations .....	77
<b>6.5</b>	<b>Profiles .....</b>	<b>77</b>
6.5.1	Cross-passages and Refuges .....	78
6.5.2	Shafts for Access and Ventilation.....	78
<b>6.6</b>	<b>Tunnel Ventilation System Facilities.....</b>	<b>80</b>
<b>6.7</b>	<b>Tunnel Approaches.....</b>	<b>81</b>
<b>6.8</b>	<b>Tunnel Construction Requirements.....</b>	<b>81</b>

<b>6.9</b>	<b>Tunnel Operational Requirements.....</b>	<b>82</b>
<b>6.10</b>	<b>Huntington Drive Interchange.....</b>	<b>83</b>
<b>7.0</b>	<b>Architectural Renderings.....</b>	<b>86</b>
<b>7.1</b>	<b>Portals .....</b>	<b>87</b>
7.1.1	Type A Portal Wall Dominant Options .....	87
7.1.2	Type B Landscape Dominant Options.....	88
7.1.3	Portal Renderings.....	90
<b>8.0</b>	<b>Preliminary Environmental Analysis.....</b>	<b>102</b>
<b>8.1</b>	<b>Introduction.....</b>	<b>102</b>
<b>8.2</b>	<b>Existing Conditions.....</b>	<b>102</b>
8.2.1	Noise .....	102
8.2.2	Air Quality .....	102
8.2.3	Land Use .....	103
8.2.4	Historic Properties .....	103
8.2.5	Archeological Impacts .....	104
8.2.6	Hazardous Materials/Waste .....	104
8.2.7	Storm Water and Drainage.....	104
8.2.8	Parklands and Recreational Facilities .....	104
<b>8.3</b>	<b>Environmental Constraints.....</b>	<b>105</b>
8.3.1	Location of Portals.....	105
8.3.2	Ventilation Buildings and Shafts .....	106
8.3.3	Construction Related.....	107
<b>8.4</b>	<b>Potential Impacts that Could Occur and Typical Mitigation Measures.....</b>	<b>108</b>
8.4.1	Noise .....	108
8.4.2	Air Quality .....	109
8.4.3	Historic Properties .....	110
8.4.4	Aesthetics.....	110
8.4.5	Archeological Impacts .....	111
8.4.6	Hazardous Materials and Waste.....	111
8.4.7	Disposal of Soil During Construction.....	111
8.4.8	Storm Water Impacts .....	111
<b>8.5</b>	<b>Summary.....</b>	<b>112</b>
<b>9.0</b>	<b>Cost Analysis and Schedule .....</b>	<b>114</b>
<b>9.1</b>	<b>Introduction.....</b>	<b>114</b>
<b>9.2</b>	<b>Methodology .....</b>	<b>115</b>
9.2.1	Study Alignment and Main Tunnel Elements.....	115
9.2.2	Tunnel Excavation Comparison.....	116
9.2.3	Other Tunnel Cost Elements.....	116
<b>9.3</b>	<b>Assumed Construction Schedule and Sequencing .....</b>	<b>117</b>

<b>9.4</b>	<b>Operations and Maintenance</b> .....	<b>122</b>
<b>9.5</b>	<b>Summary of Cost Estimate</b> .....	<b>122</b>
<b>10.0</b>	<b>Potential Funding</b> .....	<b>124</b>
<b>10.1</b>	<b>Purpose of Financial Strategy Report</b> .....	<b>124</b>
<b>10.2</b>	<b>Potential Funding Sources</b> .....	<b>124</b>
10.2.1	Federal Sources.....	124
10.2.2	State Sources.....	126
10.2.3	Proceeds from the Sale of Previously Acquired Right-of-Way.....	127
10.2.4	Tolling.....	128
<b>10.3</b>	<b>Screening of Sources</b> .....	<b>131</b>
<b>10.4</b>	<b>Financial Scenarios</b> .....	<b>133</b>
<b>10.5</b>	<b>Financial Scenarios Without Tolling</b> .....	<b>137</b>
10.5.1	Scenario 1.....	137
10.5.2	Scenario 2.....	138
10.5.3	Scenario 3.....	139
<b>10.6</b>	<b>Scenarios with Tolling</b> .....	<b>140</b>
10.6.1	Scenario 4.....	141
10.6.2	Scenario 5.....	142
10.6.3	Scenario 6.....	143
10.6.4	Scenario 7.....	144
<b>10.7</b>	<b>Next Steps</b> .....	<b>145</b>
<b>11.0</b>	<b>Feasibility Assessment Conclusions</b> .....	<b>148</b>
<b>11.1</b>	<b>Introduction</b> .....	<b>148</b>
<b>11.2</b>	<b>Physical Feasibility</b> .....	<b>148</b>
11.2.1	Traffic Considerations .....	148
11.2.2	Geologic and Geotechnical Considerations.....	151
11.2.3	Tunnel Technology.....	152
11.2.3.1	Horizontal Alignment .....	153
11.2.3.2	Vertical Alignment.....	153
11.2.3.3	Tunnel Cross-Sectional Requirements.....	154
11.2.3.4	Tunneling Methods .....	154
11.2.3.5	Fault Crossings.....	155
<b>11.3</b>	<b>Environmental Feasibility</b> .....	<b>155</b>
11.3.1	Potential Impacts and Mitigation Measures.....	156
11.3.1.1	Noise .....	156
11.3.1.2	Air Quality .....	157
11.3.1.3	Historic Properties .....	158
11.3.1.4	Archeological Impacts .....	159
11.3.1.5	Hazardous Materials/Waste .....	159

11.3.1.6	Disposal of Soil During Construction.....	159
11.3.1.7	Storm Water Impacts .....	159
<b>11.4</b>	<b>Financial Feasibility.....</b>	<b>160</b>
11.4.1	Financial Feasibility.....	160
11.4.2	Financial Strategy .....	160
11.4.3	Financial Strategy Development.....	161
11.4.4	Potential Funding Sources .....	162
11.4.4.1	Federal Sources.....	162
11.4.4.2	State Sources.....	163
11.4.4.3	Regional/Local Sources .....	163
11.4.4.4	Tolling.....	163
11.4.5	Financial Scenarios.....	163
<b>11.5</b>	<b>Summary.....</b>	<b>164</b>
11.5.1	Summary Points.....	164

## List of Figures

<b>Figure 2-1</b>	<b>A86 Tunnel Schematic Tunnel Cross Section.....</b>	<b>6</b>
<b>Figure 2-2</b>	<b>Schematic of A-86 Tunnel and Emergency Exit Shaft.....</b>	<b>7</b>
<b>Figure 2-3</b>	<b>Rendering of M 30 Tunnel cross section with cross passages between tunnels for emergency use.....</b>	<b>9</b>
<b>Figure 2-4</b>	<b>East Portal – Shows Approach Structure and Reversible Lanes Below .....</b>	<b>10</b>
<b>Figure 2-5</b>	<b>Traditional Rendering of Mt. Baker Ridge Tunnel Showing Stacked Drift Construction Concept, Bike Lane at Tunnel Crown .....</b>	<b>10</b>
<b>Figure 2-6</b>	<b>Park and Vent Structures above west approach cut.....</b>	<b>11</b>
<b>Figure 3-1</b>	<b>Regional Physiography and Active Faults .....</b>	<b>14</b>
<b>Figure 3-2</b>	<b>Geotechnical Profile 1 .....</b>	<b>17</b>
<b>Figure 3-3</b>	<b>Geotechnical Profile 2 .....</b>	<b>18</b>
<b>Figure 3-4</b>	<b>Geotechnical Profile 3 .....</b>	<b>19</b>
<b>Figure 3-5</b>	<b>Geotechnical Profile 4 .....</b>	<b>20</b>
<b>Figure 4-2</b>	<b>Section through Earth Pressure Balance TBM.....</b>	<b>35</b>
<b>Figure 4-3</b>	<b>Slurry TBM (spoil material pumped out in slurry) .....</b>	<b>36</b>

<b>Figure 4-4 Slurry Face TBM used for the 4th Tube, Elbe River Tunnel, Hamburg, Germany</b>	<b>36</b>
<b>Figure 4-5 Precast Segmental lining for A-86 Tunnel, France</b>	<b>38</b>
<b>Figure 4-6 Typical SEM Excavation Sequence – with Dowels Around Circumference</b>	<b>40</b>
<b>Figure 4-7 SEM Construction</b>	<b>40</b>
<b>Figure 4-8 Roadheader for Tunnel Mining</b>	<b>41</b>
<b>Figure 4-9 Longitudinal Ventilation with Jet Fans</b>	<b>46</b>
<b>Figure 4-10 Example of a Portal Building Ventilation Arrangement for Longitudinal Ventilation using a Saccardo Nozzle</b>	<b>51</b>
<b>Figure 4-11 Example of a Mid-Tunnel Ventilation Arrangement for Longitudinal Ventilation using a Saccardo Nozzle</b>	<b>51</b>
<b>Figure 5-1 2030 Route 710 Tunnel Average Daily Traffic (in PCE)</b>	<b>54</b>
<b>Figure 5-2 2030 Route 710 Tunnel AM Peak Hour Traffic (in PCE)</b>	<b>56</b>
<b>Figure 5-3 2030 Route 710 Tunnel PM Peak Hour Traffic (in PCE)</b>	<b>57</b>
<b>Figure 5-4 Route 710 Tunnel Configuration Scenarios</b>	<b>58</b>
<b>Figure 5-5 Comparison of Scenarios</b>	<b>59</b>
<b>Figure 5-6 Freeway Traffic Pattern Changes from 2030 Base</b>	<b>61</b>
<b>Figure 5-7 2030 BASE AM and PM Peak Hour Arterial Streets Traffic Volumes</b>	<b>63</b>
<b>Figure 5-8 2030 Traffic Pattern Changes – Scenario 6 and 7 vs. Base Arterials Streets</b>	<b>64</b>
<b>Figure 5-9 2030 Volume to Capacity Ratios</b>	<b>65</b>
<b>Figure 6-1 Cross Section Matrix</b>	<b>71</b>
<b>Figure 6-2 Alignment Map</b>	<b>76</b>
<b>Figure 6-3 Typical Profile</b>	<b>79</b>
<b>Figure 7-1 Landscape Prototype Images</b>	<b>89</b>
<b>Figure 7-2 Portal Option 1</b>	<b>90</b>
<b>Figure 7-3 Portal Option 2</b>	<b>91</b>



<b>Figure 7-4 Portal Option 3 .....</b>	<b>91</b>
<b>Figure 7-5 Portal Option 4 .....</b>	<b>92</b>
<b>Figure 7-6 Portal Option 5 .....</b>	<b>92</b>
<b>Figure 7-7 Portal Option 6 .....</b>	<b>93</b>
<b>Figure 7-8 Tunnel Roadway Approach.....</b>	<b>94</b>
<b>Figure 7-9 Ventilation Tower Profile 1 .....</b>	<b>95</b>
<b>Figure 7-10 Ventilation Tower Profile 2 .....</b>	<b>95</b>
<b>Figure 7-11 Ventilation Tower Profile 3 .....</b>	<b>96</b>
<b>Figure 7-12 Ventilation Tower Profile 4 .....</b>	<b>96</b>
<b>Figure 7-13 Ventilation Tower Profile 5 .....</b>	<b>97</b>
<b>Figure 7-14 Ventilation Tower Profile 6 .....</b>	<b>98</b>
<b>Figure 7-15 Ventilation Tower Landscape Feature.....</b>	<b>98</b>
<b>Figure 7-16 Ventilation Tower w/ Cross Section .....</b>	<b>99</b>
<b>Figure 7-17 Ventilation Tower- Bird’s Eye View.....</b>	<b>100</b>
<b>Figure 9-1 Schedule For TBM Construction.....</b>	<b>120</b>
<b>Figure 9-2 Schedule For SEM Construction .....</b>	<b>121</b>
<b>Figure 10-1: Composition of Proposed Revenues – No Toll Revenue Bond Scenarios .....</b>	<b>134</b>
<b>Figure 10-2: Composition of Proposed Revenues – Toll Revenue Bond Scenarios .....</b>	<b>135</b>
<b>Figure 10-3 Scenario 1: (48% Federal, 12% State, 40% Regional/Local) Capital Funding Required, by Year (2006 Dollars).....</b>	<b>138</b>
<b>Figure 10-4 Scenario 2: (30% Federal, 20% State, 50% Regional/Local) Capital Funding Required, by Year (2006 Dollars).....</b>	<b>139</b>
<b>Figure 10-5 Scenario 3: (30% Federal, 12% State, 58% Regional/Local) Capital Funding Required, by Year (2006 Dollars).....</b>	<b>140</b>
<b>Figure 10-6 Scenario 4: (30% Federal, 12% State, 28% Regional/Local, 30% Toll Revenue Bonds) Capital Funding Required, by Year (2006 Dollars).....</b>	<b>141</b>

<b>Figure 10-7 Scenario 5: (25% Federal, 12% State, 33% Regional/Local, 30% Toll Revenue Bonds) Capital Funding Required, by Year (2006 Dollars).....</b>	<b>143</b>
<b>Figure 10-8 Scenario 6: (10% Federal, 12% State, 38% Regional/Local, 40% Toll Revenue Bonds) Capital Funding Required, by Year (2006 Dollars).....</b>	<b>144</b>
<b>Figure 10-9 Scenario 7: (0% Federal, 12% State, 38% Regional/Local, 50% Toll Revenue Bonds) Capital Funding Required, by Year (2006 Dollars).....</b>	<b>145</b>
<b>Table of Tables</b>	
<b>Table 5-1 Route 710 Gap Closure Alternatives Analyzed.....</b>	<b>52</b>
<b>Table 9-1 Estimate of ROM Construction Costs .....</b>	<b>123</b>
<b>Table 10-1: Potential Federal Funding Sources for the Route 710 Tunnel Project...</b>	<b>124</b>
<b>Table 10-2: Potential State, User Fee, Regional and Local Funding Sources for the Route 710 Tunnel Project.....</b>	<b>126</b>
<b>Table 10-3: Order of Magnitude Toll Revenue and Level of Bonding Estimate – Autos Only (2006 dollars).....</b>	<b>128</b>
<b>Table 10-4: Estimated Percent of Total Construction Cost Paid by Toll Revenue Bonds – Autos and Trucks.....</b>	<b>130</b>
<b>Table 10-5: Levels of Federal, State, Regional/Local and Toll Revenue Funding Comprising the Financial Scenarios (2006 dollars) .....</b>	<b>133</b>
<b>Table 10-6: Preliminary Route 710 Tunnel Financial Scenarios - No Toll Revenue Bonds (2006 dollars) .....</b>	<b>133</b>
<b>Table 10-7: Preliminary Route 710 Tunnel Financial Scenarios – Includes Toll Revenue Bonds (2006 dollars) .....</b>	<b>136</b>

## **ES 1.0 Executive Summary**

### **ES 1.1 Project Background**

The Interstate 710 (I-710) “Long Beach” freeway serves as a major north-south link in the Los Angeles County transportation network. The freeway is an extensively traveled facility and its level of service has deteriorated as congestion and demand grow within the corridor. This facility currently extends from its southern terminus in the City of Long Beach to Valley Boulevard, just north of the Interstate 10 (I-10) “San Bernardino” freeway near the boundary between Cities of Los Angeles and Alhambra. Beyond this northern terminus is a 4.5 mile gap in the Route 710 until the freeway resumes at Del Mar Boulevard, in the City of Pasadena, where it extends 0.6 miles to the north --- to its junction with the Interstate 210 (I-210) “Foothill” freeway.

The California Department of Transportation (Caltrans), Federal Highway Administration (FHWA), the Southern California Association of Governments (SCAG) and the Los Angeles County Metropolitan Transportation Authority (MTA) support the completion of Route 710 to relieve regional and local traffic congestion and to enhance regional air quality. Consequently, SCAG has included this project in its Regional Transportation Plan (RTP) since 1989 and in its Regional Transportation Improvement Plan (RTIP) since 1991.

Over the past forty years, alternative concepts have been proposed and evaluated to complete the I-710 freeway and close the 4.5 mile gap in the corridor. To date, none of the previously proposed and evaluated alternatives has been successful in satisfying the regional mobility needs and community/ environmental concerns. These alternatives were traditional “surface” freeway alternatives through the communities of Los Angeles, South Pasadena and Pasadena. All alternatives considered traversed through highly developed urbanized neighborhoods and required a substantial volume of right-of-way along the alignments. Many members of the community were concerned with the impact of these “right-of-way” intensive “surface” alternatives and consequently, opposed to the extension of the Route 710 freeway. In response to this reaction and to lessen the potential impact of completing the Route 710 freeway, a tunnel concept was proposed for assessment as a potential option to the surface alternatives.

### **ES 1.2 Tunnel Technical Feasibility Assessment**

The MTA, in conjunction with Caltrans, has taken the initiative to conduct this technical assessment to evaluate the feasibility of constructing a tunnel to complete Route 710 freeway between Valley Boulevard and Del Mar Boulevard. Recent advances in tunnel construction technologies appear to give merit to completing the Route 710 corridor using a tunnel. This technical feasibility assessment is intended to ascertain whether the tunnel concept is physically, environmentally and financially viable, as well as resulting in congestion relief, and worthy of more comprehensive evaluation and technical consideration. A map of the Route 710 Tunnel Study Area is shown in Figure ES-1.

Figure ES 1 Study Area Map

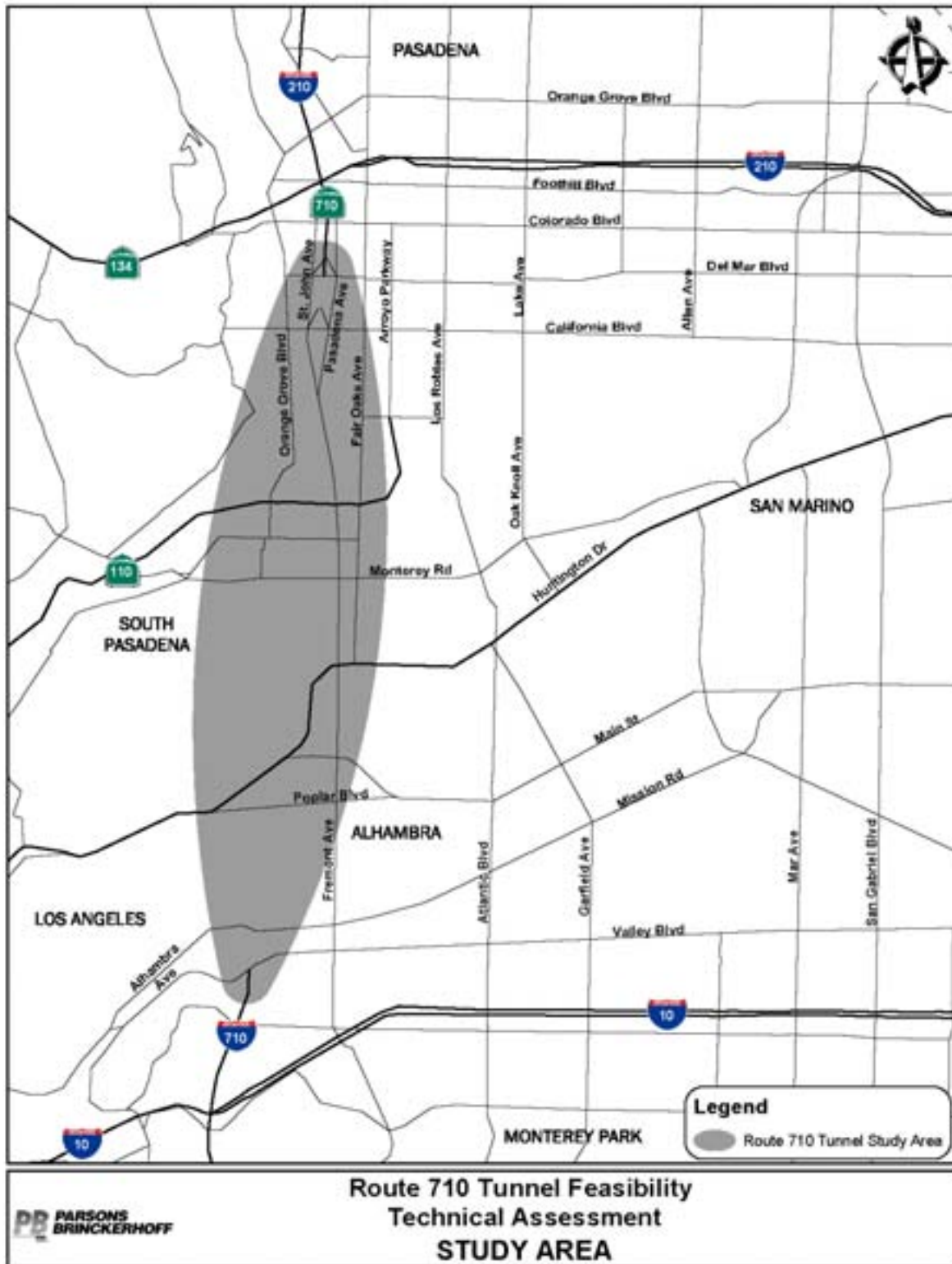

The intent of the assessment is to determine the feasibility of completing this freeway gap by tunneling underground. Specifically, this evaluation is principally focused on deep subterranean bored or mined tunnel construction methods instead of the more environmentally intrusive shallow trench excavation or “cut-and-cover” tunnel methods. The purposes of this feasibility study were to:

- Determine if a tunnel is technically, operationally and financially feasible;
- Identify preliminary potential physical, environmental, and financial impacts to neighboring communities;
- Validate the concept of a bored tunnel(s); and
- Develop a preliminary project scope and cost estimates.

Although this assessment has examined a variety of issues related to a tunnel, it was by no means intended to be comprehensive nor exhaustive in scope. The purpose of this assessment is to serve as a technical foundation to allow decision-makers sufficient information to determine what appropriate actions should be initiated regarding the tunnel option.

### **ES 1.3 Tunnel Technical Feasibility Assessment – Findings**

Based upon the technical feasibility assessment, the tunnel concept appears physically and environmentally feasible. The technical feasibility assessment considered a range of tunnel alternatives and features with the construction cost ranging from approximately \$2.3 billion to \$3.6 billion (2006 dollars). As part of financial strategies, a number of potential fund sources including federal, state, local and toll revenues were explored. Based on these preliminary findings, it is determined that the tunnel concept is technically viable and warranted to be advanced for more comprehensive and detailed evaluations to validate the findings of this assessment.

### **ES 1.4 Physical Feasibility**

One of the primary purposes of this assessment was to evaluate the viability and suitability of implementing a tunnel through the Route 710 Gap based on current engineering and construction practices. This assessment was performed in consideration of the suitability of the geotechnical, geologic, hydrological, seismic conditions and the ability of the tunnel concept to satisfy traffic demand, highway standards, ventilation requirements, and other safety criteria.

The subsections below provide a brief discussion of some of the major physical elements that led to the conclusion that the tunnel option is physically feasible.

### ES 1.4.1 Tunneling Technologies

Over the past thirty years, significant advancements have been made in the field of tunnel construction. Current tunnel construction practices and methods have seen tunnels constructed with interior dimensions approaching the fifty-foot threshold. The traffic modeling and forecasting results of this technical assessment indicate that tunnels of this magnitude will be necessary to accommodate the anticipated traffic demand along the Route 710 corridor.

This technical assessment focused on deep tunneling as the primary construction method for the tunnel scenario. The two types of excavation methods were examined including the Tunnel Boring Machine (TBM) method and the Sequential Excavation Method (SEM) technique. The TBM method uses a large mechanized excavator to bore the full diameter opening while the SEM technique uses smaller equipment to excavate several small diameter shafts or drifts to construct the full tunnel opening. See Figures ES 2 and ES 3 and Section 4 of this report for further descriptions of these techniques. Both of these construction methods are routinely used in the tunneling industry depending on the geologic conditions, length of the tunnel, cross-sections, project schedule, and various other considerations. It is anticipated that the use of surface trenching or “cut-and-cover” tunnel construction method will be limited to the shallower transition areas near the tunnel portals.

For the Route 710 tunnel concept, both the TBM and SEM construction techniques are considered valid for the anticipated conditions along the corridor and the size needed to accommodate the anticipated traffic demand.

Figure ES-2 Tunnel Boring Machine – Madrid, Spain



**Figure ES-3 Sequential Excavation Method of Construction**

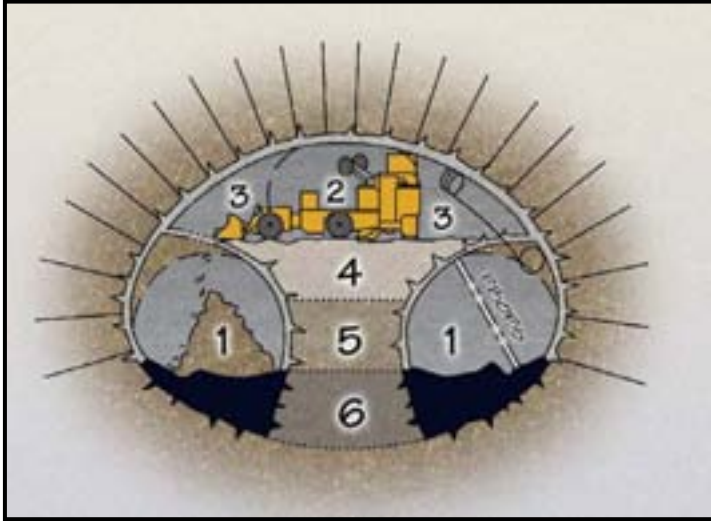

#### **ES 1.4.2 Physical Characteristics**

Based upon the limited existing geologic and geotechnical information and the exploratory drilling program conducted for this feasibility assessment, the physical ground properties are considered to be suitable for tunneling in the study area. Although the conditions appear favorable for tunneling, there are several subsurface challenges that need to be quantified including location of the seismic faults and depth of the groundwater. Consequently, significant additional subsurface investigation is needed to more fully characterize the subsurface conditions.

#### **ES 1.4.3 Traffic Demand**

As a result of the traffic modeling and analysis, it was determined that the 2030 forecast demand along this proposed section of the Route 710 freeway would require four lanes of traffic in each direction to provide an acceptable level of service. As described above in Section ES 1.4.1, current tunneling technologies are capable of constructing tunnels of the size warranted to accommodate the anticipated traffic demand. Consequently, it will be necessary to construct a minimum of two tunnels to meet the anticipated two-way demand along the corridor.

In general, the traffic modeling revealed that the completion of the Route 710 would result in a re-distribution of traffic within the regional area surrounding the gap. Many trips that now use local arterials will use the Route 710 tunnel and some trips on adjacent freeways will transfer to the Route 710 freeway. Except for freeway segments at the two ends of the tunnel, the re-distribution of trips throughout the study area has generally positive impacts on arterial network and the surrounding freeways.

**ES 1.5 Environmental Feasibility**

The focus of the preliminary environmental assessment was to identify and address the potential tunnel issues and impacts -- impacts associated with both the construction and operation of a major highway tunnel -- to the adjacent and surrounding communities and the local environment within the study area. And, finally to determine if any of these issues or constraints will preclude additional consideration of the tunnel concept to complete the Route 710 freeway.

From the environmental perspective, the tunnel concept appears to be viable and feasible. Environmental impacts to the following resources may occur: noise, air quality, historic properties, aesthetics, archaeology, hazardous waste, soil disposal, and storm water. However the impacts or the severity of the impacts can be minimized, eliminated or mitigated using proven measures and techniques. Based upon this preliminary environmental assessment, no insurmountable environmental issues have been identified that would preclude further consideration of the tunnel alternative.

If a decision is made to advance the tunnel concept, more comprehensive consideration would be needed to further identify and quantify the potential environmental impacts of this concept within the Study Area and in close regional proximity of the corridor.

**ES 1.6 Financial Feasibility**

The funding sources and financial scenarios considered in this report provide a starting point for development of a financial plan for the project, should the tunnel concept be advanced. The Route 710 gap closure is a project of regional significance. This technical assessment examined a myriad of tunnel alternatives that would provide four-lanes of traffic per direction. The construction cost estimates for these alternatives were prepared with the estimates ranging from approximately \$2.3 billion to \$3.6 billion (2006 dollars). A cost estimate of \$3 billion (2006 dollars) was used for the purposes of identifying potential funding sources and developing financial strategies to reflect the range of tunnel alternatives considered.

As part of this technical assessment, several potential financial strategies were developed that considered various federal, state, regional, and local funding sources. These sources included traditional funding sources and non-traditional sources such as bonds leveraged from anticipated toll revenues. Using these revenue sources and assumptions on the level of contribution from each source, seven preliminary financial scenarios were developed -- including four scenarios that contained toll based financing.

**ES 1.7 Conclusion**

It is the conclusion of this technical feasibility assessment that the tunnel concept to complete the Route 710 freeway is feasible from the physical perspective. Further, since the anticipated environmental issues or impacts can be eliminated, minimized or mitigated by proven methods, the concept also appears to be environmentally feasible. Although, the determination of the



financial feasibility is dependent on several external factors, it is warranted that the tunnel concept be advanced to the next more detailed stage to further validate the findings of this assessment and to determine whether the tunnel concept can ultimately serve as the alternative to complete the Route 710 freeway.

## 1.0 Introduction

### 1.1 Project Background

The Interstate 710 (I-710) “Long Beach” freeway serves as a major north-south link in the Los Angeles County transportation network. The freeway is an extensively traveled facility and its level of service has deteriorated as congestion and demand grow within the corridor. This facility was developed as one of the early freeways in the Los Angeles basin and it currently extends from its southern terminus in the City of Long Beach to Valley Boulevard, just north of Interstate 10 (I-10) “San Bernardino” freeway in the cities of Los Angeles and Alhambra. Beyond this northern terminus is a 4.5 mile gap in the Route 710. At Del Mar Boulevard, in the City of Pasadena, the I-710 freeway resumes and extends north 0.6 miles to its junction with the Interstate 210 (I-210) “Foothill” freeway.

The California Department of Transportation (Caltrans), Federal Highway Administration (FHWA), the Southern California Association of Governments (SCAG) and the Los Angeles County Metropolitan Transportation Authority (MTA) each supports the completion of Route 710 to relieve regional and local traffic congestion and to enhance regional air quality. Consequently, SCAG has included this project in its Regional Transportation Plan (RTP) since 1989 and in its Regional Transportation Improvement Plan (RTIP) since 1991. Over the past forty years, alternative concepts have been proposed and evaluated to complete the Route 710 freeway. To date, none of the previously proposed and evaluated alternatives has been successful in satisfying both regional mobility needs and community/environmental concerns.

The MTA has taken the initiative to conduct this study to evaluate the constructing of a tunnel to complete Route 710 and to close the missing segment between Valley Boulevard and Del Mar Boulevard. Recent advances in tunnel construction technologies may be applicable to the Route 710 tunnel concept in the determination of this concept’s physical, environmental and financial viability.

In April 2005, the MTA retained the firm of Parsons Brinckerhoff (PB) as the engineering consultant to perform the Route 710 Tunnel Feasibility Technical Assessment to determine whether it would be prudent to initiate further and more comprehensive evaluations of a tunnel alternative to complete Route 710.

### 1.2 Project History

The **first Draft Environmental Impact Statement (DEIS)** was circulated in 1975, which included draft and supplemental environmental documents relating to an at-grade solution to provide closure of the ‘Gap.’

The **SR-710 Final Environmental Impact Statement**, Volumes I and II, (FHWA and Caltrans) **was issued in 1992** providing the final environmental document within the official Federal and State environmental processes. This FEIS summarized previous environmental documents from

the first DEIS of 1975 and updates to all of the environmental resources and their impacts within the project area.

The **Route 710 Meridian Variation Enhancement and Mitigation Advisory Committee** produced a **Final Report in 1993**, which summarized the main environmental issues and included mitigation recommendations to advance the project and obtain a Record of Decision (ROD) for the at-grade “Meridian Route”. A summary of the public comments is also included in the Final Report.

Another 1993 report provided **Caltrans’s Recommendations** for the Route 710 Meridian Variation Enhancement and Mitigation Advisory Committee. In this report, it was concluded that the proposed Meridian Variation alternative would have significant impacts in all the local communities, but that impacts and required mitigation measures would vary for each city. The affected local communities were skeptical of the implementation of the mitigation measures recommended in both the FEIS and the report. Recommendations of the report were to reduce the footprint of the alternative, to ban trucks on the proposed facility, and thus reduce environmental impacts associated with the project.

In 1996, Caltrans District 7 produced the **Route 710, ‘Model Evaluation of the City of South Pasadena’s Multi - Mode Low Build Proposal**. In this document, general trends were observed in terms of expected traffic volume reductions of 10 per cent to 50 per cent to the major streets in the area, with a freeway gap closure. This modeling effort did not specifically address the issue of truck traffic.

The next main development was the **1998 FHWA Record of Decision**, which selected a modified version of the Meridian Variation Alternative as described in the FEIS. This version was named the **‘Depressed Meridian Variation Alternative Reduced with Shift’** design variation. This modified version was selected to reduce overall impacts of the project by reducing the highway width, including sections of depressed alignment below ground level in residential areas, providing short sections of cut-and-cover tunnel, making an alignment shift to avoid the Short Line Villa Tract Historic District, and making a commitment to further depress the highway in the El Sereno area of the City of Los Angeles and in South Pasadena.

Also in **1998, Caltrans District 7** produced the document entitled **‘Questions and Answers and Preliminary Design Plans’**. Topics covered included: the purpose of the project; benefits of closing the gap; adverse impacts; air quality; proposed ways to decrease environmental impacts; project cost and funding source; a brief summary of lawsuits filed from March 1973 to June 1998; a proposed “Low-Build” Plan; and suggested ‘next steps.’ It also provided a colorized strip map showing project features such as the connector ramp or auxiliary lanes, bridge, new street connection, busway / HOV lane, shoulder and historic resources.

In **1999, a Motion for Preliminary Injunction** was heard by Judge Dean D. Pregerson of the **U.S. District Court** Central District of California. Judge Pregerson granted in part and denying

in part the Plaintiff's complaints regarding the extension of the 710 Freeway. The plaintiffs were the City of South Pasadena, the National Trust for Historic Preservation, the Sierra Club, the California Preservation Foundation, the Los Angeles Conservancy, Pasadena Heritage, the South Pasadena Preservation Foundation, and the South Pasadena Unified School District. The defendants were the United States Secretary of Transportation, the Federal Highway Administrator, the Federal Highway Administration (FHWA), the Director of the California Department of Transportation, and Caltrans.

This Complaint sought a preliminary injunction preventing future planning and monetary expenditures, and imposed certain requirements on the defendants. The court determined that a preliminary injunction was appropriate and ruled that the defendants would be prohibited from specific actions to extend the 710 Freeway and further actions regarding the disposition of right-of-way related to the proposed 710 Freeway. This court order granted and denied elements of the plaintiffs' motion for the preliminary injunction, and this injunction remains in effect today.

### **1.3 MTA Team**

The sponsor of this tunnel technical feasibility assessment is MTA, Transportation and Implementation (Planning) Division. A study team consisting of staff from the MTA's San Gabriel Valley Team was charged with the project management, project guidance and oversight, and the outreach efforts relating to this Feasibility Assessment. It was also assigned responsibility for execution of the feasibility study, providing direction to the study team, and principal review of the study products.

Additionally, the MTA study team was responsible, along with its consultant, for coordinating the study with other public agencies including Caltrans, SCAG, and affected local jurisdictions.

### **1.4 MTA Tunnel Advisory Panel**

During the study, the team was also advised by the MTA internal Tunnel Advisory Panel (TAP), which is comprised of the following recognized underground experts:

- Dr. Dan Eisenstein, Professor Emeritus of Civil Engineering, University of Alberta
- Dr. Geoffrey Martin, Professor of Civil Engineering, University of Southern California

TAP was consulted throughout the study to review previous related reports and to advise on tunneling and geotechnical aspects of the study deliverables including the Technical Memoranda and Final Report.

### **1.5 MTA Working Group**

In addition to the MTA Study Team, TAP, and the Consultant Team, another important committee of project stakeholders to this feasibility assessment was the Working Group which

included technical staff representatives from Caltrans, SCAG and the cities of Alhambra, La Canada Flintridge, Los Angeles, Pasadena, San Marino, and South Pasadena.

The MTA study team has met on an approximately monthly basis with the Working Group to obtain the Working Group's input on the development of all tasks of the feasibility assessment.

## **1.6 Study Goals and Objectives**

The intent of the assessment is to determine the feasibility of completing this freeway gap by tunneling. Specifically, this evaluation has principally focused on mined tunneling construction methods rather than more environmentally intrusive 'cut-and-cover' tunneling methods. The purposes of this feasibility study were to:

- Determine if a tunnel is technically, operationally and financially feasible;
- Identify preliminary potential physical, environmental and financial impacts to neighboring communities;
- Validate the concepts for a mined tunnel(s); and
- Develop a more refined project scope and cost estimates.

Although this assessment has examined a variety of issues related to a tunneled gap closure, it is by no means intended to be comprehensive and exhaustive in scope. The objective has been to determine whether a tunnel solution would be feasible and worthy of further consideration so that the responsible agency(ies) may determine the next appropriate actions needed for closure of the Route 710 Gap in accordance with local, state and federal project development guidelines.

The study tasks included examination of world tunneling achievements, identification of examples of similar completed tunnels, examination of available local geological information, a review of possible tunneling technologies, initial traffic modeling, and identification of feasible tunnel configurations and alignment to be used as the basis of the initial feasibility assessment. With these assumptions it was then possible to examine potential environmental issues that would need to be addressed and to identify potential aesthetic solutions to illustrate possible concepts for mitigating visual impacts of tunnel structures. Rough order of magnitude costs and financial analysis were included to allow an assessment of project feasibility.

## 2.0 Summary of Large Highway Tunnels Domestic and International

For background on similar tunnel projects, this chapter provides a summary of large diameter (two to three lanes each direction) vehicular tunnels from around the world. The tunnels reviewed represent many of the world's most recent large diameter road tunnels that feature state-of-the-art construction methods, equipment, and operational concepts.

In general, these tunnels are in urban environments and are either complete, under construction, or in planning phases. Technologies used and lessons learned from these projects may be applicable to the proposed Route 710 Tunnel.

In addition, MTA's Tunnel Advisory Panel (TAP), in its February 2005<sup>1</sup> report on Tunneling Feasibility, identified over 40 roadway tunnels world-wide.

For this feasibility study task, tunnel projects were selected as being of particular interest due to tunnel size, urban environments, tunneling technology used, traffic volumes, and operational practice. These projects include:

- A-86 Malmaison, France
- SMART, Kuala Lumpur, Malaysia
- Westersschelde, Netherlands
- 4<sup>th</sup> Tube Elbe River, Hamburg, Germany (and Lefortovo Tunnel, Moscow)
- M30, Madrid, Spain
- Mrazovka Highway, Prague, Czechoslovakia
- Dublin Port Tunnel, Ireland
- Mt. Baker Ridge, Seattle, Washington
- Melbourne City Link, Melbourne, Australia
- Caldecott Tunnel, Oakland, California
- Hsuehshan (also known as Pinglin), Taiwan

Of these similar tunnels, the three considered most comparable are presented for this report: the A-86, M30, and Mount Baker Ridge projects. These tunnels have similar intended function of a multi-lane highway, in an urbanized setting and their cross section and configuration requirements also have some similarities. More information on tunnels' physical characteristics, construction methods, configuration (single or multiple tunnels, number of lanes), fire/life safety elements, and operational information (single or joint use tunnel, mixed traffic or "auto-only" use) follow.

---

<sup>1</sup> Eisenstein, Dan and Geoffrey Martin, MTA Tunnel Advisory Panel, "Report on Tunneling Feasibility: Preliminary Geological and Geotechnical Evaluation and Review of Associated Tunneling Technologies, February, 2005

## 2.1 A-86 Tunnel, Malmaison, France

The A-86 tunnel project is a large diameter highway tunnel currently under construction near Paris, France in the town of Malmaison.

This tunnel is under construction as of May 2006 by the French government, in association with the Cofiroute Company under a Design-Build-Operate contract. Two separate tunnels have been planned. The first (east) tunnel, which is projected to be completed for revenue service in 2007, is a stacked, two-level roadway configuration and is approximately six miles in length, with a large diameter planned to carry truck traffic and may be completed at a later stage. This tunnel is considered comparable to the Route 710 tunnel project due to its size, configuration and function as a multi-lane highway in a suburban, environmentally sensitive area. Figure 2-1 illustrates its proposed stacked two-lane configuration.

This project extends the existing A-86 motorway to complete the final link of the outer ring road around greater Paris. It passes under areas of forest, parkland, historic sites and residential areas. Environmental restrictions were the driving force behind the tunnel section. The tunnels will be toll financed. The east tunnel will be 6.2 miles long, for light vehicles only. The second (west) tunnel will be 4.7 miles long and will include heavy vehicles and trucks.

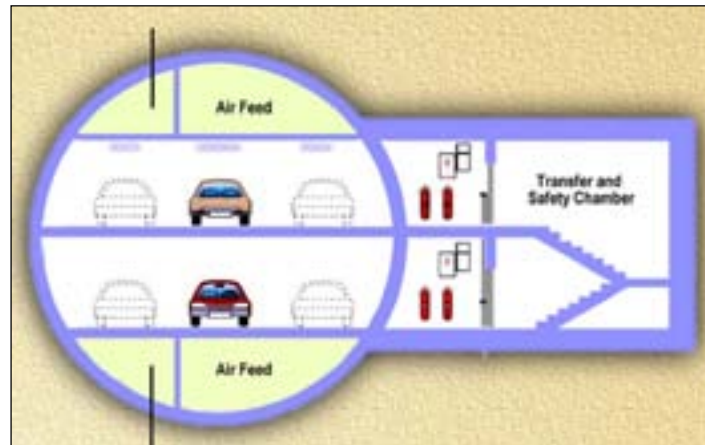
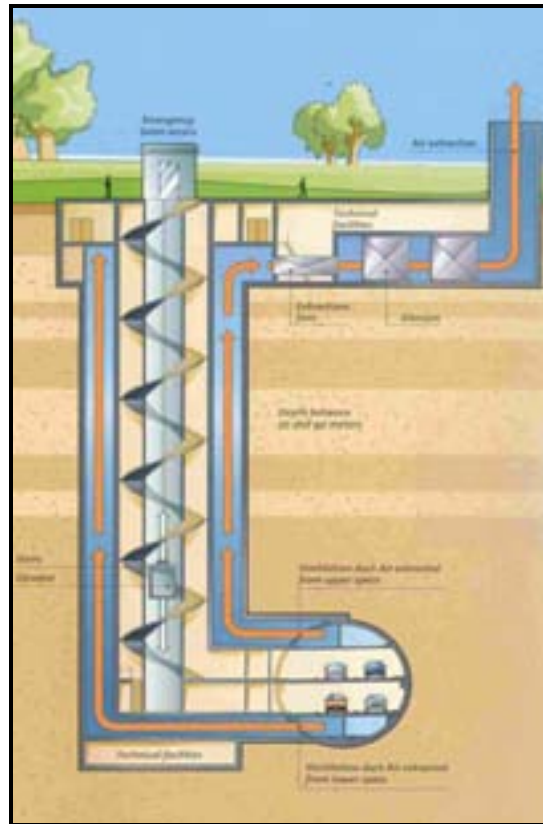

Figure 2-1 A86 Tunnel Schematic Tunnel Cross Section



**Figure 2-2 Schematic of A-86 Tunnel and Emergency Exit Shaft**

The tunnel’s inside diameter of 34 ft. allows an internal height of 8.4 ft per level. This clearance allows vehicles of 6.6 ft. or less to enter the tunnel, thus accommodating most private and small commercial vehicles in France. Each traffic level is sealed and independent, with its own ventilation system. There are two traffic lanes and one emergency lane in each direction.

Geologic conditions at the location are variable including sands, limestones, and clays with variable groundwater conditions. The tunnel is being constructed using a Tunnel Boring Machine (TBM) with pressure-face capability. The TBM operation modes adjust for soil conditions and can be changed from Earth Pressure Balance (EPB) to Slurry to “open” in rock conditions. The lining consists of pre-cast concrete segments. Chapter 4 provides more information on tunneling technology.

Ventilation and safety features will include a full transverse ventilation system and an incident detection system. The DIVA (Instant Detection of Stationary Vehicles) system uses a system of cameras at 330 ft. spacing and a central control system to monitor for problems. Twenty-four hour surveillance is also to be provided by security agents who will patrol and assist users.

Refuge bays are provided at 650 ft spacing. The bays can be sealed and pressurized to house up to 100 people each, and would also allow the people to keep in contact with the central tunnel



monitoring station. Each bay has a stairway connecting to the upper or lower tunnel levels for evacuation. Exit shafts to the surface (Figure 2-2) are spaced on the average of approximately 3,300 ft.

Smoke extraction systems are sized for large accidents involving light vehicles. Smoke release hatches are provided at minimum 1,300 ft. spacing. Drivers upstream of the fire are protected from smoke through smoke venting and directional blowing of fresh air to the venting shaft. A fire suppression system will be installed that automatically activates in event of fire by releasing water through a misting network. This system was tested under simulated conditions (real tunnel fire in similar tunnel configuration) at a test facility in Switzerland.

## **2.2 M30 Project Madrid, Spain**

The M30 motorway in Madrid, Spain is at the center of a major urban renewal project and serves as the city's inner ring road. As of 2004, congestion on the existing road was considered a "barrier" to traffic movement in the urban area. Project objectives were to refurbish the existing roadway and to re-route major sections through tunnels under the city to allow existing paved surface areas to be restored to green spaces and new housing. The project has 15 separate sections and four regions. The South By-Pass twin tunnel portion is 2.2 miles in length and the tunnel has a 50-ft outside diameter. The project is currently under construction by the Spanish government and tunneling for the first bore of the large diameter road will be completed in mid-2006. The project has two tunnels providing three traffic lanes in each direction, on single level road decks.

This tunnel now has the distinction of being driven using the largest Earth Pressure Balance TBM. Geologic conditions consist of clays and sandy clays typical of the Madrid area. The tunnel lining is prefabricated concrete, bolted, gasketed segments each 28 inches thick and 6.5 feet in length. Features of this tunnel include inspection and escape routes from under the roadways (Figure 2-3), as well as gas detection (CO, NO<sub>2</sub>) and alarms, and fire suppression systems.

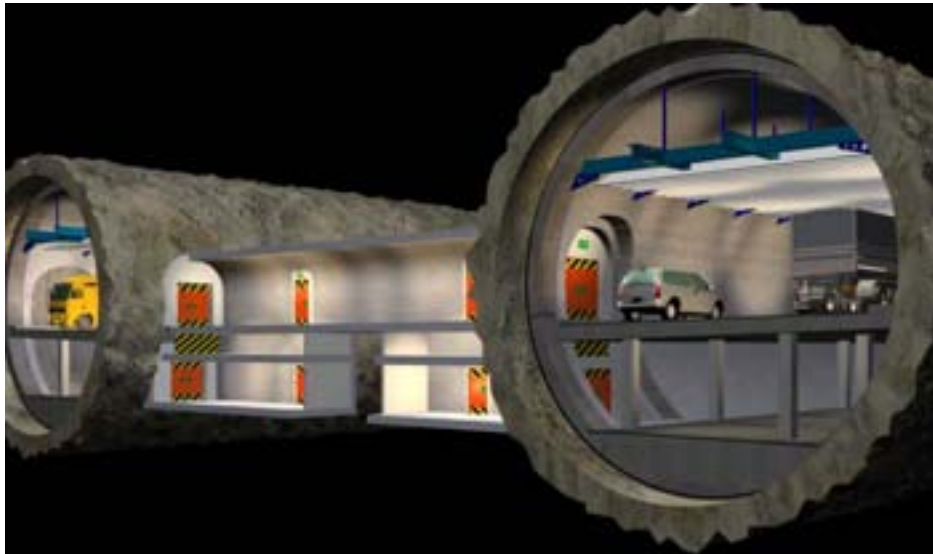

**Figure 2-3** Rendering of M 30 Tunnel cross section with cross passages between tunnels for emergency use.

### 2.3 Mt. Baker Ridge Tunnel, Seattle, Washington

This highway tunnel connects western Seattle through Mount Baker Ridge and onto a bridge structure over Puget Sound. It was completed in 1986, is 1500 feet long, and provided five additional traffic lanes, on 2 levels, built alongside the original 1940s tunnel. The large diameter tunnel, as opposed to several smaller tunnels, was “mandated” by public input to reduce effects on the overlying residential area and to reduce required rights of way. The tunnel supplemented an existing tunnel constructed decades earlier. An innovative “stacked drift” method of construction was used in which a tunnel lining consisting of 24 individual concrete-filled drifts were constructed to form the initial tunnel lining, followed by removal of the soil core (Figures 2.4 and 2.5). The tunnel diameter is about 87 ft. in outside diameter, with two and three lanes of traffic on the upper and lower levels respectively. Traffic on the lower level is reversible for commute directions. A bike path enters the tunnel at the upper most level.

The west approach to the Mount Baker Ridge Tunnel includes a cut and cover section and the ventilation structures. This cut and cover area was later incorporated for use as parkland (Figure 2.6). Additional safety features of this relatively short tunnel include an automatic fire detection and foam suppression system.

The ‘stacked drift’ construction method used was well suited to the shallow, soft soils found along that alignment to achieve the large spans required for the traffic cells. The method is relatively slow but adequate for this short length of tunnel. It would not be appropriate when compared to other methods for a much longer, relatively deep tunnel in soft rock conditions anticipated on the Route 710 alignment.



**Figure 2-4** East Portal – Shows Approach Structure and Reversible Lanes Below



**Figure 2-5** Traditional Rendering of Mt. Baker Ridge Tunnel Showing Stacked Drift Construction Concept, Bike Lane at Tunnel Crown



**Figure 2-6** Park and Vent Structures above west approach cut and cover section

This Page Intentionally Left Blank

### 3.0 Geotechnical Evaluation

Evaluation of tunneling feasibility requires information of sub-surface geologic and groundwater conditions. This chapter provides background from previous studies and some new investigation for this feasibility study.

#### 3.1 Regional Geology and Tectonics

The Los Angeles region lies along the boundary of the Western Transverse Mountain Ranges on the north and the Peninsular Ranges on the south. The region is characterized by northerly trending hills and valleys on the south and east-west trending hills and valleys on the north. The Los Angeles region is an area of active geological deformation (tectonics) and earthquakes. Presently the site region is in regional crustal compression oriented in a north-northeast direction as determined from geological structure, earthquakes, and both land and space geodetic surveys. The region is contracting at about 0.19 to 0.35 in/year. The boundaries between the mountains and the valleys are generally coincident with geological earthquake faults.

Except for a few marginal zones, the geologic structure of the San Gabriel basin is characterized by relatively flat-lying, late-Quaternary (between 700,000 years ago and the present day) strata overlying folded Pliocene to Miocene-age strata (29 million up to 1.8 million years ago). The central part of the basin is a deep trough that rises abruptly due to faulting and folding at the Sierra Madre fault zone (Figure 3-1 illustrates regional faults).

The bulk of seismotectonic activity in the San Gabriel Basin region during Quaternary time appears to have occurred along the Sierra Madre, Hollywood, and Whittier faults which border the more prominent uplifts in the Los Angeles Basin. The Raymond Hill fault (also referred to as the Raymond fault) had activity but probably at a lesser rate. If these characteristics can be applied basin wide, the greatest tectonic activity within late Pleistocene time has occurred primarily in proximity to the major surface faults such as the Santa Monica-Hollywood, Newport Inglewood Structural Zone, Whittier, and Sierra Madre faults. The subsurface thrust faults within the region have not been active enough to create similar prominent uplifts, and only a few (e.g. Santa Fe Springs) have even subtle recognizable surface expression.

#### 3.2 Site Geology

The tunnel study assumed initial alignments lie within a corridor along the western margin of the San Gabriel Basin which constitutes a broad southerly sloping plain within the transition zone between the Western Transverse Ranges and the Peninsular Ranges. The northern reach of the route corridor (north of the Raymond Hill fault) is commonly referred to as the Raymond Basin. The San Gabriel/Raymond Basin(s) is bordered on the north by the San Gabriel Mountains, on the west by the Repetto Hills, on the south by the Puente Hills, on the east by the San Jose Hills.

The basin floor comprises broad alluvial fans, gently sloping to the south-southeast, overlying folded sedimentary rocks in the southern part of the alignment corridor and crystalline basement rocks in the northern part. Most of the route is characterized by flat ground or subtle small

Figure 3-1 Regional Physiography and Active Faults

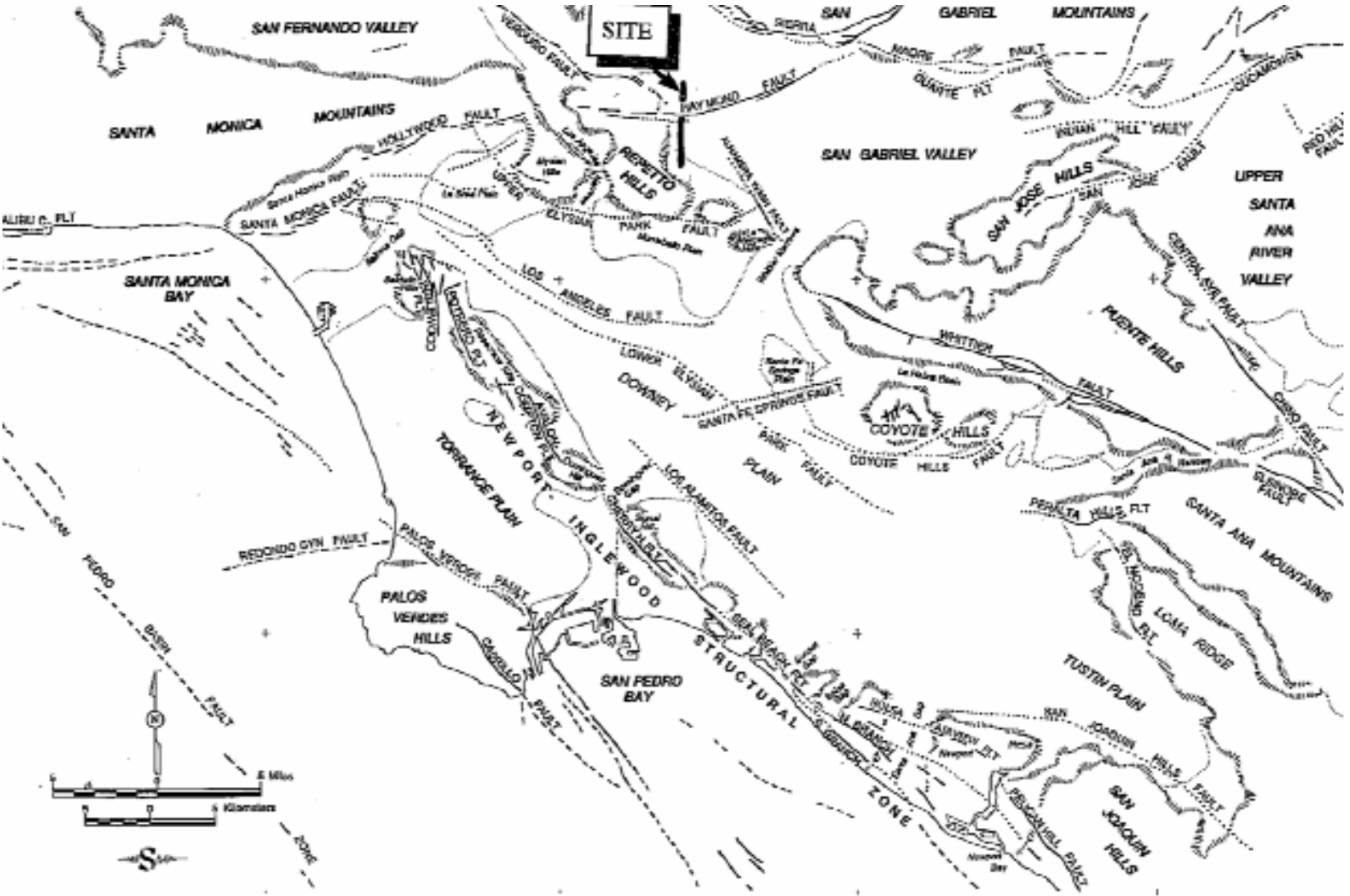

rounded rises, but several higher hills occur just west of the alignment corridor. Elevations along the assumed study alignments range from about 820 feet in the north to about 420 feet in the south for an elevation change of about 400 feet. The highest elevation along the route corridor is at Raymond Hill which rises to an elevation of about 830 feet. Outcrops of folded bedrock occur locally as small hills and knolls along the alignment corridor and in the Repetto Hills to the west.

### 3.3 Stratigraphy and Structure

The stratigraphy and the structure of the site vicinity are presented on a longitudinal profile along tunnel study corridor in Figures 3.2 through 3.5. From the San Bernardino Freeway (I-10) north to the concealed extension of the York Boulevard fault (at Mission Street), the stratigraphy consists generally of thinly-bedded Tertiary (about 67 to 2 million years old) shale and siltstone of the Puente (Monterey) Formation unconformably overlain by Quaternary (less than 10,000 years) alluvium. It should be noted that different investigators have assigned different names to the same formations. Generally speaking, the Monterey and the Puente formations (noted on the profile) are very similar rocks of about the same age and, for engineering purposes, can be considered the same lithologic unit.

#### 3.3.1 Crystalline Basement Rock

Along the assumed tunnel study profile, basement rock has the potential to be encountered only from north of the Eagle Rock fault near Glenarm Street to the Foothill and Ventura freeways. Basement rock will likely consist of Cretaceous quartz diorite: (geologic map symbol **qd**), a massive, non-gneissoid quartz diorite; and (**gqd**), and massive to gneissoid quartz diorite, which locally includes unmapped biotite-rich gneiss.

There is little subsurface information on these rocks locally. While crystalline basement rock has been encountered in a few water well borings located north of the Eagle Rock fault, the geological logging for those borings was generalized and is of limited usefulness. A previous boring by Caltrans (boring ES-3) and an EMI boring (06-2), placed for this project, located further south, encountered granodiorite basement rock at a depth of about 150 ft. The rock, described as mostly soft and weathered to highly weathered, may not be typical of basement rock north of the Eagle Rock fault. The nearest surface exposures are in Arroyo Seco about a kilometer to the west of the route corridor.

#### 3.3.2 Topanga Formation

The Topanga Formation, of middle and/or late Miocene age (10 to 20 million years ago) unconformably overlies crystalline basement rock. Along the assumed tunnel profile it would be encountered north the Raymond Hill fault zone to the Eagle Rock fault. Along this reach, the Topanga Formation is found at or very near surface to an estimated 3,000 ft depth (Dibblee, 1989). The formation is subdivided into three units: (**Ttqdc**), a gray to brown, crudely bedded conglomerate and breccia, all composed of biotite hornblende quartz diorite in semi-friable sandstone matrix, very similar in appearance to granodiorite; (**Ttsc**), a light gray to brown, semi-friable sandstone, and interbedded brown sandy to silty shale, semi-siliceous shale, and pebble-conglomerate of quartz diorite detritus; and (**Ttqdb**), a gray to brown breccia, massive to vaguely



bedded, composed of angular detritus and a few rounded cobbles and boulders, all of biotite hornblende quartz diorite.

Figure 3-2 Geotechnical Profile 1

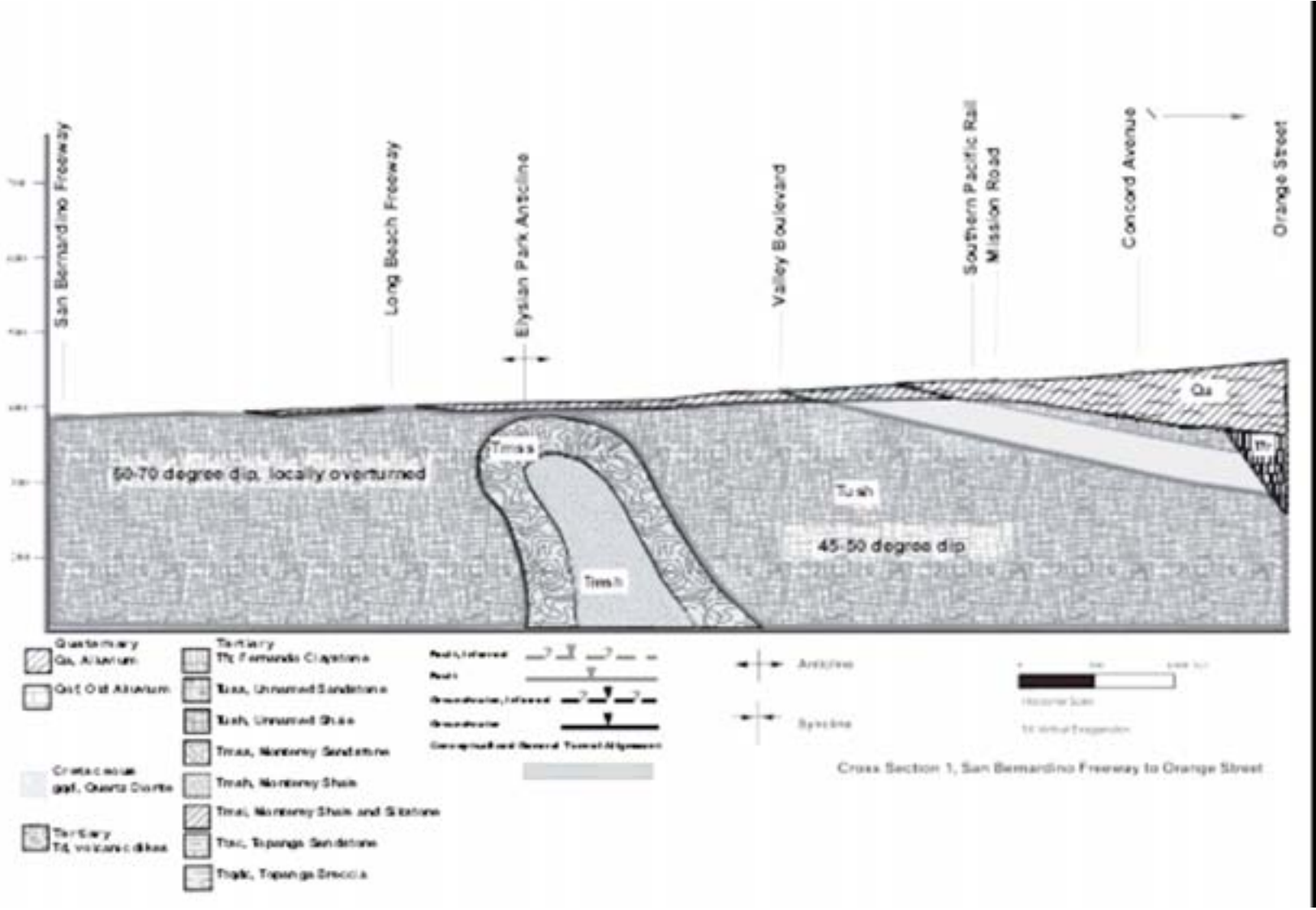

Figure 3-3 Geotechnical Profile 2

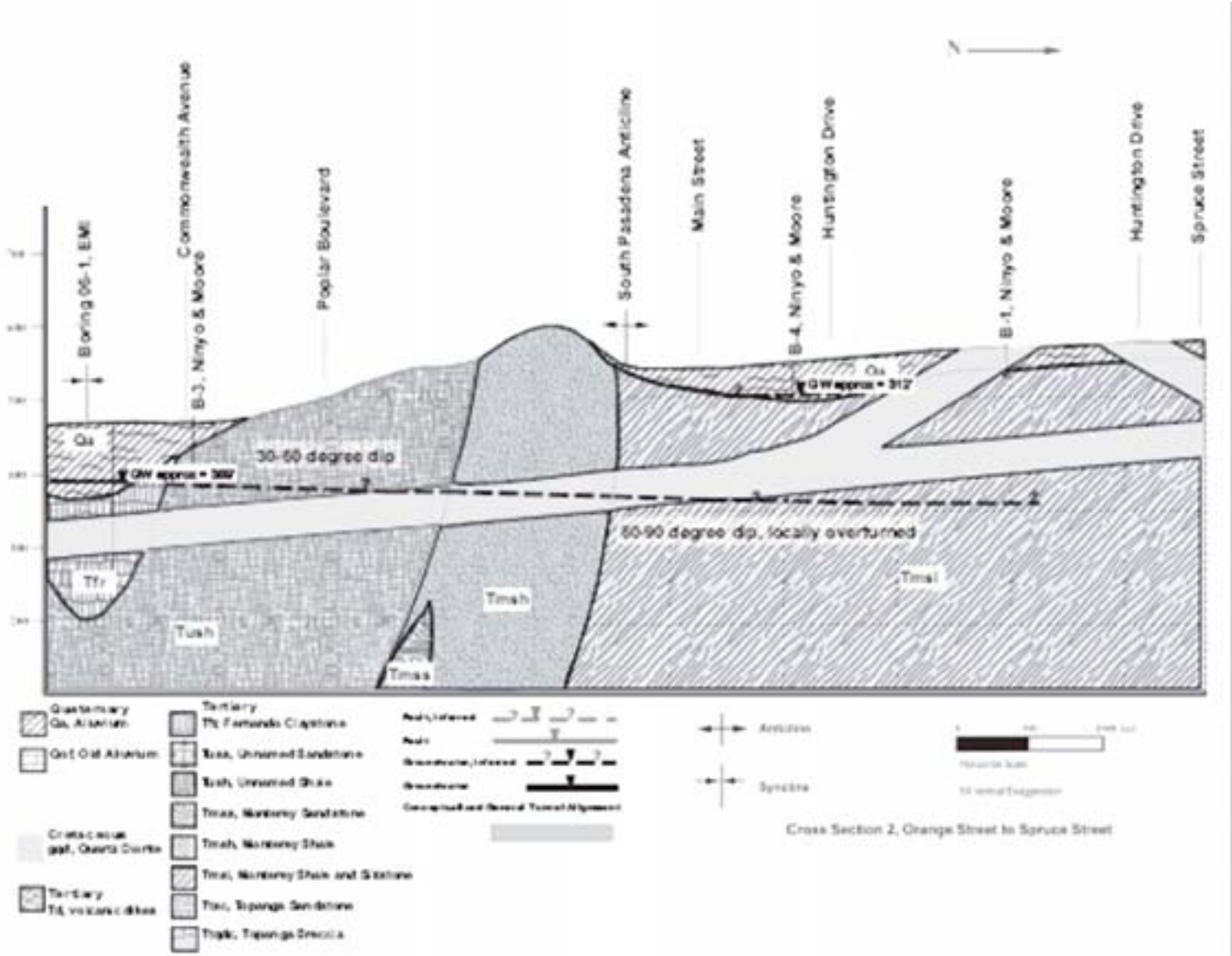

Figure 3-4 Geotechnical Profile 3

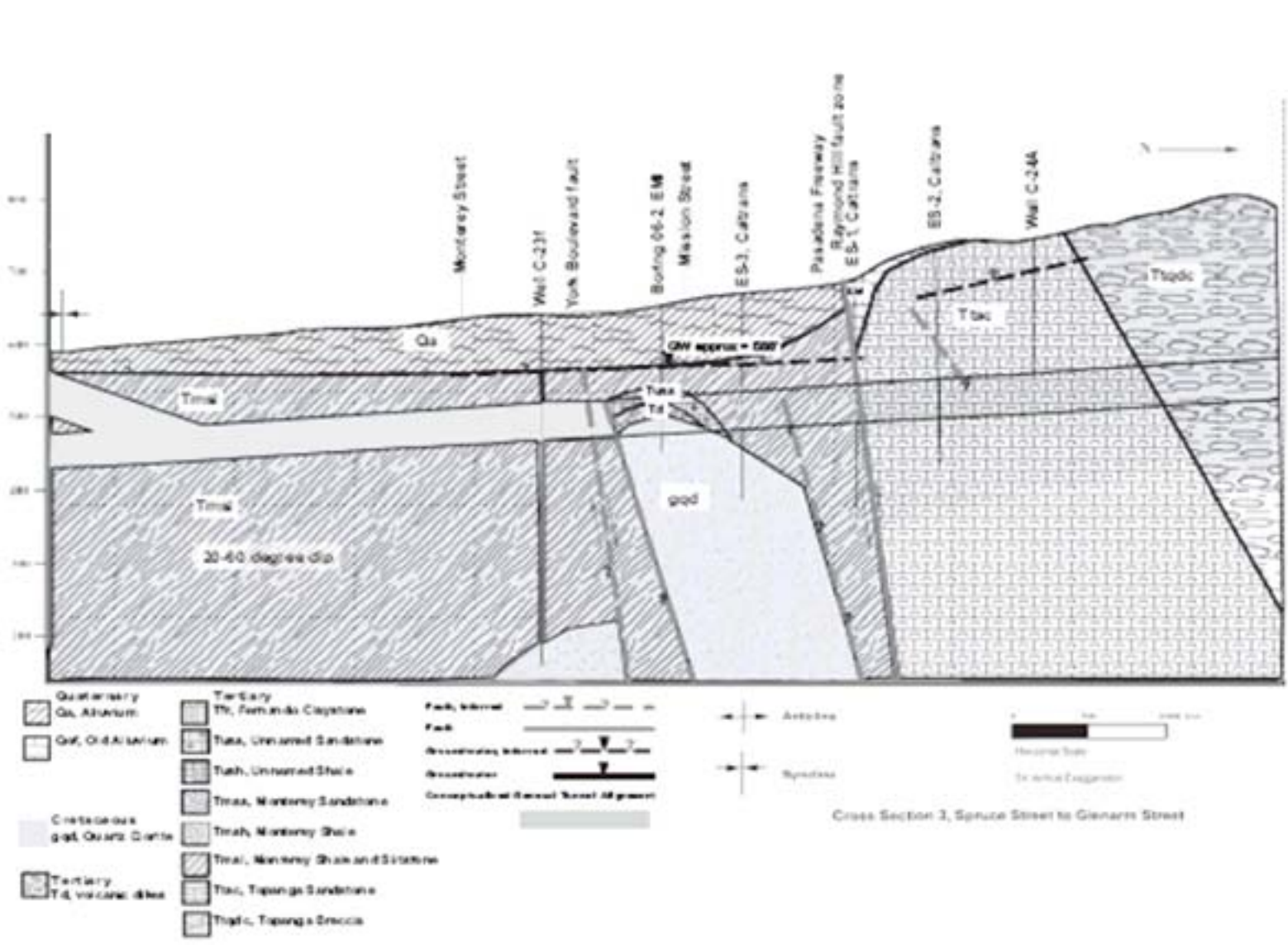
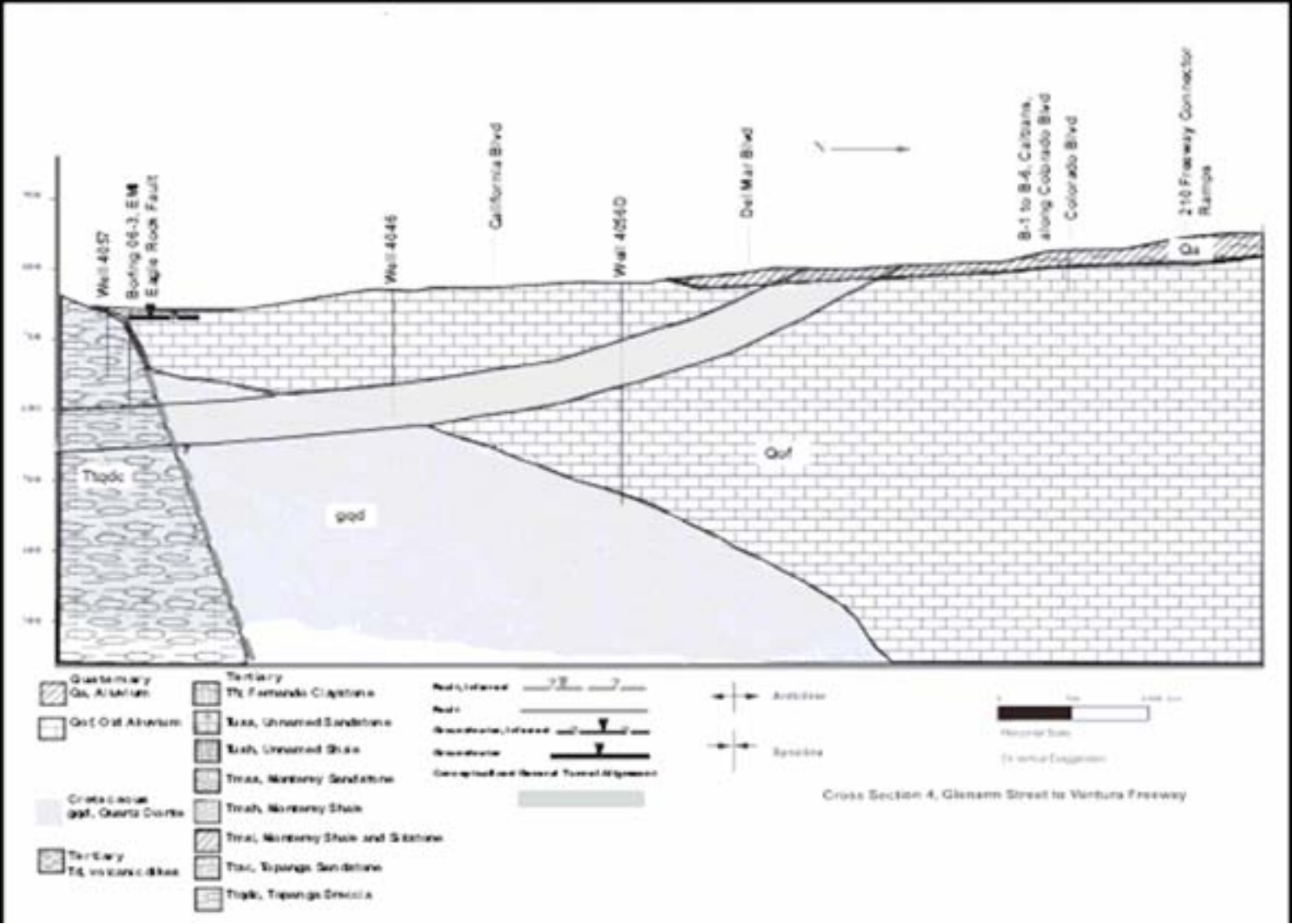

Figure 3-5 Geotechnical Profile 4



### 3.3.3 Monterey/Puente Formation

The Monterey/Puente Formation will be encountered between approximately Hellman Avenue to Valley Boulevard and from Hampton Terrace to the York Boulevard fault (Mission Street) along the study profile (Figures 3.2 to 3.5). As stated previously, the Monterey and Puente formations have been shown interchangeably on various maps. These formations are very similar in characteristics, and therefore no attempt was made to distinguish between them for tunneling characterization. The Monterey/Puente Formation is a marine deposit of middle- to late-Miocene age and conformably overlies and the Topanga Formation. The Monterey/Puente Formation is subdivided into three units: (**Tmsh**), a white-weathering, thin-bedded, platy, siliceous shale which is locally porcelaneous and silty; (**Tmss**), a tan to light gray, semi-friable, arkosic sandstone which includes some interbedded silty shale; and (**Tmsl**), a gray, micaceous silty shale and siltstone. Tmsl rocks are considered by Lamar (1970) to be part of the Topanga Formation.

### 3.3.4 Unnamed Shale

The late-Miocene-age marine “unnamed” shale of Dibblee is referred to as a member of the Puente Formation by others (e.g. Lamar, 1970). Along the study profile this material would be encountered between the San Bernardino Freeway to Hellman Avenue and Valley Boulevard to Hampton Terrace. The shale is subdivided into two units: (**Tush**), a gray to light-brown, thinly bedded, silty clay shale, locally containing scattered large calcareous nodules; in places the subunit contains thin interbeds of fine-grained sandstone; the lower part locally contains thin lenses of light tan, platy, semi-siliceous or diatomaceous shale; (**Tuss**) consists of light gray to tan, semi-friable, sandstone with thin interbeds of silty shale.

### 3.3.5 Fernando Formation

The Fernando Formation includes over three thousand ft thickness of Pliocene siltstone, sandstone, pebbly sandstone, and conglomerate. The formation is generally soft, poorly indurated, and friable. The formation is most extensive just south of the assumed route corridor, but would be encountered for a short section between Concord and Commonwealth Avenues. The geotechnical properties of this formation are not greatly different than the Monterey/Puente rocks.

### 3.3.6 Quaternary Alluvium

Surficial sediments unconformably overlie bedrock along the flat-lying ground surface of assumed tunnel corridor. While depth of alluvium is not well-known throughout the project area, south of the Eagle Rock fault, based on previous borings it is not believed to exceed about 100 ft in thickness and is likely much less over most of the area. Except near the tunnel portals where the tunnel depth is shallow, it is unlikely that deposits will be encountered along tunnel profile. Quaternary alluvium is divided into the following subunits: (**Qa**), unconsolidated Holocene floodplain deposits of silt, sand and gravel; (**Qg**), Holocene stream channel deposits of gravel, sand and silt; and (**Qof**), Pleistocene alluvial fan gravel and sand.

### 3.4 Faults

As described in Section 3.1 of this chapter, the area has undergone active geologic deformation. Active faults in proximity of, or crossing the corridor, will influence tunnel design for ground shaking and displacements during earthquakes. The following summarizes the known faults which could impact the seismic criteria for tunnel design.

#### 3.4.1 Sierra Madre Fault

The Sierra Madre fault is one of the major faults in the Los Angeles region and lies along the southern margin of the San Gabriel Mountains and along the northern edge of the San Fernando Valley and the San Gabriel Valley. The fault zone is very complex and over much of its length comprises several sub-parallel branches. The fault may also be divided into segments along length with somewhat different rupture characteristics and histories. For example, the Raymond Hill fault, which crosses the Study area, intersects the Sierra Madre fault in the Sierra Madre area and aligns with similar faults (Clamshell-Sawpit faults) north of the Sierra Madre fault, thus suggesting a fundamental discontinuity in the Sierra Madre fault. About 12.4 miles of the westernmost part of the Sierra Madre fault ruptured during the 1971 San Fernando earthquake (moment magnitude,  $M_w = 6.7$ ).

#### 3.4.2 Santa Monica-Hollywood Fault System

One of the major faults in the Los Angeles Basin is the frontal fault system along the southern edge of the Santa Monica Mountains, separating Mesozoic-age plutonic and metamorphic rocks from Tertiary sedimentary rocks. The fault system consists of the Santa Monica and Hollywood faults and smaller segments such as the Malibu and Potrero faults. The Santa Monica Mountains rise abruptly to 1600-2000 ft above the Los Angeles Basin floor and are indicative of a large vertical component of faulting as well as a left-lateral component.

There have been no large historical earthquakes associated with the Santa Monica-Hollywood fault system, but geological studies (e.g. Crook and Proctor, 1992; Drumm, 1992; Dolan et al, 2000) have documented late-Quaternary faulting. Although it seems certain that the fault system is one of the major active features in the Los Angeles Basin, success at determining slip rates and recurrence intervals has been limited. The most recent surface rupture on the Hollywood fault appears to have occurred 6,000 to 9,000 years ago (Dolan et al., 2000).

The Metro Rail Red Line has driven a tunnel through the Hollywood segment of the fault system. The tunneling and boring program found the plutonic rocks of the Santa Monica Mountains uplifted and thrust over 262 to 328 ft. of alluvium and colluvium (Guptill et al, 1997).



### 3.4.3 Raymond Hill Fault

One of the major faults along the project study corridor is the Raymond Hill fault or as commonly referred to, the Raymond fault. The Raymond Hill fault is about 16 miles long and extends approximately east-west through the communities of San Marino, Arcadia, and South Pasadena. The fault zone crosses the Study area in the vicinity of the Pasadena Freeway, where the freeway is oriented East-West.

The Raymond Hill fault is characterized by left-lateral oblique reverse slip. This fault dips at about 75 degrees to the north. The rate of slip is between 0.003 and 0.008 in/yr. The fault has been considered by some geoscientists to be interconnected with the Hollywood fault because they have similar trends and similar types of displacement. However, the disparity between recurrence intervals and the age of latest surface rupture suggests they are discrete features. The Caltrans seismic map considers Raymond Hill fault as part of the Malibu Coast-Santa Monica-Hollywood-Raymond fault system (MMR) and is assigned an earthquake magnitude of 7.5.

The most recent major rupture occurred in Holocene time, about 1,000 to 2,000 years ago (Weaver and Dolan, 2000). From paleoseismic and trenching studies of the slip rate of the Raymond Hill fault, there is geological evidence of at least eight surface-rupturing events along this fault in the last 40,000 years. At least five surface ruptures occurred in the past 40,000 years. However, four of these events occurred between 31,500 and 41,500 years ago (Weaver and Dolan, 2000). This indicates that surface ruptures occur over very irregular intervals and may be more random than systematic.

### 3.4.4 York Boulevard Fault

The York Boulevard fault trends east-west through Repetto Hills. Very little is known about the fault and it is not believed to be active. In the central part of the fault, Pliocene-age rocks are inferred to be faulted against basement rocks. The vertical separation would be more than 10,006 ft. (Lamar, 1970). The slip rate is unknown. The fault is projected across the assumed corridor by Dibblee (1989) and is shown as a subsurface fault south of the Raymond Hill fault on Figure 3.3.

### 3.4.5 Eagle Rock Fault

The Eagle Rock fault trends southeasterly for about 11 miles from the southwestern flank of the Verdugo Hills across the southern part of Pasadena (Figure 3.5). The fault appears to be a northerly dipping thrust fault. Very little is known about the fault. The slip rate is probably on the order of less than 0.003 in/yr (Wesnousky, 1986). The fault may be interconnected with the Verdugo fault to the northwest. The fault extends toward the projection of the Alhambra Wash fault but no evidence of any connection has ever been suggested.

## 3.5 Local Seismicity

The southern Los Angeles area is well known to be seismically active. In the project Study area, two small but locally significant earthquakes occurred in the Pasadena region in 1988 and 1991.



The 1988 earthquake had a magnitude of 4.9 ( $M_w$ ) and may have occurred on the Raymond Hill fault at a depth of about 10 miles. (Jones et al, 1990). The 1991 earthquake had a magnitude of 5.8 ( $M_w$ ) and occurred at a depth of about 7 miles. below the San Gabriel Mountains.

A number of regional faults are capable of producing ground shaking at the project site. A number of earthquakes of moderate to major magnitude have occurred in the Southern California area in the last 73 years. The earliest of these was the magnitude 6.4 ( $M_w$ ) Long Beach earthquake, with an epicenter over 35 miles to the south-southeast of the study area. More recently, the magnitude 6.7 ( $M_w$ ), Northridge earthquake (1994) caused moderate shaking in the project area.

Design of tunnels for ground shaking would need to consider regional seismicity and the latest fault models.

### **3.6 Structure Along Tunnel Study Alignment**

Along the tunnel project study area, the bedrock units are folded into a series of synclines and anticlines and broken by at least three, possibly four, major faults. The complex structure of the project study site is a result of large-scale regional tectonics, including the oblique contraction of the Los Angeles Basin through a combination of strike-slip and thrust faulting near-surface and at depth.

Strike of bedding throughout the project study site is generally southeast-northwest to east-west. From the San Bernadino Freeway north to approximately Valley Boulevard is the Elysian Park anticline. The axis of the northwest-trending anticline is positioned approximately at Hellman Avenue. Oskin, et. al (2000) estimated the contraction rate of the Elysian Park anticline to be 0.02-0.04 in./yr. South of Hellman Avenue, beds are steeply dipping to the south to locally overturned. North of Hellman Avenue, beds dip moderately to steeply to the northeast into a syncline structure centered approximately at Orange Street.

From Orange Street north to approximately Main Street, bedding dips moderately to steeply to the south-southwest. Near Main Street, bedding generally becomes very steep to locally overturned.

Between Main Street and Alhambra Road is the axis of a very tight fold within the bedrock. The southern arm of a syncline is defined by moderately to locally steeply dipping beds from approximately Alhambra Road north to Spruce Street, the syncline axis. Beds of the northern arm of this syncline dip moderately to the south and are cut by the York Boulevard fault near Mission Street.

The York Boulevard fault, whose surface trace is concealed and assumed to cross the tunnel study corridor near Mission Street, and the nearby Raymond Hill fault zone, crossing the corridor at the Pasadena Freeway, are believed to have similar orientation, striking east-west and steeply north-dipping (approximately  $75^\circ$ ). Between the two faults is a wide zone of localized, high-angle shearing and deformation.

In Caltrans boring ES-2, located between Raymond Hill and Pasadena Freeway, at a depth of 160 ft., a potential fault dipping 65° was identified. No information on strike or dip of this unnamed potential fault has been found, nor is there any evidence from other sources to suggest that this feature is a major fault. Boring log descriptions of units above and below this fault suggest that perhaps Topanga Formation sandstone has been thrust over micaceous siltstone of the Monterey Formation. Based on bedding orientation and the orientation of the nearby Raymond Hill fault, the unnamed fault may dip to the north.

Between the unnamed ES-2 fault and the Eagle Rock fault just north of Glenarm Street, the massive to poorly bedded Topanga Formation is generally moderately to steeply dipping to the northeast. Lamar (1970) maps a fault through the northern part of the hill.

The Eagle Rock fault is projected to assumed corridor just north of Glenarm Street. Orientation of the fault is not well-defined, but is presumed to dip 60-75°NE. Other regional maps also project the San Rafael fault through the area into the same area as the Eagle Rock fault.

### **3.7 Site Exploration and Testing in 2006**

Little geotechnical and geological information is presently available to a sufficient depth in the vicinity of the study corridor. In 2005, Metro conducted a tunneling feasibility study, including a geotechnical study to characterize subsurface conditions using existing data and published mapping. In January 2006, the geotechnical engineering firm Earth Mechanics Inc. (EMI), of the MTA consultant team, conducted a limited field investigation consisting of three soil and rock borings drilled along a corridor about 4.5 miles long that confirmed expected conditions and provided additional essential but still limited geotechnical and geological information. The investigation is described in detail in EMI's Technical Data Report (2006), with a summary provided below.

#### **3.7.1 Field Exploration for Feasibility Study**

A limited field investigation was also conducted by EMI consisting of three new exploratory soil and rock borings drilled to depths of 201 to 204 ft. The borings were drilled in the cities of Alhambra, South Pasadena, and Pasadena. The borehole locations (designated 06-1 to 06-3, respectively) are shown on Figures 3-2 to 3-5. Borehole locations were selected based on geological considerations to be studied, right-of-way, site accessibility, and workspace and time restrictions.

#### **3.7.2 Testing**

A suite of laboratory classification and strength tests and microscopic petrographic analysis were conducted to determine the soil and rock characteristics, corrosion and slaking potentials, and derive initial engineering properties with particular focus on the materials in the vicinity of the tunnel bores.

### 3.7.2.1 Soil Properties

The soil alluvium encountered in the three borings predominantly consists of granular soils comprising fine to medium-grained, medium to very dense sands with varying amounts of silts and gravels. In boreholes 06-1 and 06-2, the soils transitioned to weathered bedrock and consisted of very stiff to hard clays with sand. The soil thickness decreased from about 160 ft in the south boring 06-1, to 90 ft in boring 06-2, to about 70 ft the north boring 06-3.

The characteristics of Quaternary alluvium in the northern part of the corridor has been shown by numerous other holes drilled for the Metro Gold Line light rail (Law/Crandall, 1993). Typical materials encountered were sand, silt, clay and gravel mixtures. Gravel in the alluvium comprised about 10 to 20 percent of volume and large cobbles and boulders in the 9.8 to 11.8 inch size were commonly encountered. The alluvium consists of unconsolidated poorly sorted sand and gravel. Recent alluvium has Standard Penetration Test (SPT) blowcounts of approximately 20 to 30 blows per ft, indicating medium density, and old alluvium shows much higher blowcounts in the range of 50 to over 70 blows per ft., indicating very dense material.

Based on one soil sample from each of the three recent borings, the soils did not classify as corrosive to bare metals and concrete in contact with the soils. Environmental laboratory testing of soil cuttings for the purpose of proper disposal did not reveal contaminated or hazardous substances.

### 3.7.2.2 Rock properties

The crystalline basement rock is essentially coarse-grained, highly weathered granodiorite. However, slow coring time during exploratory drilling suggests much harder rock and thus variable tunneling conditions relative to other sedimentary geologic formations encountered within the project area. Hard quartz veins scattered within the granodiorite may pose additional tunneling challenges.

The Topanga Formation consists of a sandstone member and a conglomerate and conglomeratic sandstone member. The sandstone member of Topanga Formation is well bedded fine to coarse-grained sandstone with discontinuous seams of carbonized wood and lignite coal. Bedding ranges from about 0.03 inches in thickness for the fine-grained sandstone strata to a maximum thickness of 9.84 ft for the coarse-grained strata. Interbedded are conglomeratic sandstone beds that contain boulders up to 3.2 ft in diameter. Conglomerates and conglomeratic sandstone are irregularly interbedded massive to well-bedded strata. Rock sizes range from 2.9 inches to large boulders of 3.2 ft in diameter.

Monterey/Puente Formation ranges from dull white or light gray, low-density, diatomaceous shale to hard, resistant well-bedded tan to gray siliceous shale. The diatomaceous shale tends to readily part along plane of stratification and has a high slaking potential. Furthermore when submerged underwater, the diatomaceous shale absorbs water and disintegrates into silty clay.

Most of the rock materials recovered from the project investigation were relatively soft and unfractured. Point load test and unconfined compressive strength results showed generally weak rock except for some of the finer grained sandstones and the resistant pebbles and cobbles within the conglomerates of the Topanga Formation. Both the Topanga formation and the crystalline igneous rock were generally highly weathered and soft, and failed immediately upon applying little pressure (less than 100 psi). Most of the samples of Topanga formation and crystalline basement rock (diorite) had relatively low unconfined compressive strengths (1,000-2,000 psi) and few samples had moderate strengths (5,000 to 8,000 psi). These results appear to be representative of generally soft and weak rock in the middle and northern part of the assumed tunnel corridor containing a few zones of stronger and harder rocks. The diorite and granite pebbles and cobbles within the Topanga conglomerate had high strengths (17,500 and 31,500 psi). Some of the pebbles and cobbles within the conglomerate are hard and unweathered, but are held in a weak and soft sandstone matrix. Such materials can probably be excavated relatively easily.

Previous experience by EMI in the general vicinity also provided a general characterization of the materials likely to be encountered in a tunnel. The bedrock (Monterey/Puente Formation) encountered in boreholes in the Elysian Hills-Mt. Washington part of the Elysian Hills anticline area, a short distance west of the assumed alignment corridor, consisted of thin to massive sandstone beds and thin-bedded to laminated claystone, siltstone, and shale. These rocks are similar to those cropping out in the adjacent hills.

The sandstones in the Elysian Hills-Mt. Washington area are gray to dark gray, ranging from fine- to coarse-grained but predominantly medium grained, and generally soft and friable. Most of these do not have any cementation and can be disaggregated by finger pressure. However, occasional (<1 percent) beds of light gray sandstone are hard to very hard due to cementation by calcite. The thickness of the sandstone beds recovered in the core drilling ranged from laminae (<0.39 in. thick) inter-bedded with thin claystone and siltstone to beds about 3.2 ft thick. The adjacent outcrops in the Elysian Hills indicate that thicker beds on the order of 4.9 to 6.5 ft thick may also occur.

Fine-grained materials such as claystone, siltstone, and shale occurred as thin beds in the Elysian Hills-Mt. Washington area and are generally soft to moderately soft and calcareous. These are generally various shades of gray and grayish brown to black. Bedding thicknesses range from paper-thin laminae to a few inches (commonly 1.1 to 1.5 inches). These fine-grained materials are more commonly cemented by calcium carbonate than the sandstones but still comprise weak rock, breaking under manual pressure or with light hammer blows.

Both the sandstones and the fine-grained beds are weathered and oxidized in approximately the upper 6.5 to 9.8 ft. Below about 9.8 ft depth they are fresh and unoxidized. The rocks are generally moderately to slightly fractured. Joint frequency is generally moderate (~1 per 0.98 ft), but intensely fractured zones (3-4 fractures per 0.98 ft) were encountered in every boring. Bedding-plane joints are common in the fine-grained materials. Joints are generally tight and clean. Joint roughness ranges from smooth to rough with the smooth joints most commonly occurring as bedding-plane joints in the shale and claystone. No rigorous statistical joint

analysis was conducted, but joint orientation seemed to cover the entire range of dips from horizontal to vertical (i.e. random).

Another drilling site along Soto Street just west of the southern part of the project area is on the south limb of the east-west trending Elysian Park anticline that projects to the southern part of the corridor. The borings were drilled in the Miocene-age Monterey/Puente Formation. These materials were soft rock, commonly altered to clay in borings where the material is in a constantly moist state such that it is difficult to distinguish the weathered rock from firm sandy alluvium. The sandstones generally are fine-to-medium-grained with a significant component of silt (10 to 40 percent). Where these same materials are exposed at the surface, they dry out and become soft rock. The sandstones are largely uncemented and friable, and appear more similar to sand than to sandstone. Rarely, borings encountered hard, cemented sandstone beds that were impermeable, and could not be penetrated by the hollow stem auger.

Environmental laboratory testing of rock cuttings for the purpose of proper disposal did not reveal contaminated or hazardous substances.

### **3.8 Groundwater**

Limited information is available on groundwater at depth within the project site. The California Geological Survey map shows the highest historical water level. However, it can be assumed that ground water withdrawal has lowered ground water levels throughout the region.

In the EMI boring 06-1, groundwater was measured at 66 ft depth, shallower than anticipated based on historical groundwater levels. In EMI boring 06-2, groundwater was measured at 82 ft depth. In EMI boring 06-3, it appears that the boring was impermeable and an accurate groundwater level could not be measured.

In 1999, Ninyo & Moore placed borings for Caltrans during the winter and encountered groundwater between approximately 32.8-45.9 ft depth, near the boundary between Quaternary alluvium and bedrock. It is likely that this was only perched groundwater, having accumulated above a relatively impermeable soil layer. Of the Caltrans borings, drilled during the summer of that year, only one encountered any groundwater, at a depth of 32.8 ft and was noted to be likely perched.

The California Geological Survey seismic hazard reports for the Pasadena and Los Angeles Quadrangles include generalized maps of the historically highest groundwater levels and borelog data locations. On these maps, the only bore log data from locations within the Route 710 project area are near Concord Avenue in the southern half of the project site and Glenarm Street in the northern half. Historically highest groundwater elevations at those locations are shown to be more than 200 ft below surface and 39.3 ft depth respectively. As Glenarm Street is near the axis of a large syncline filled with poorly consolidated alluvium, it is unclear if the groundwater elevation there represents the elevation of perched groundwater or of the regional aquifer.

Groundwater levels within the Raymond Hill fault zone historically were much higher than present and the fault zone is a barrier to ground water movement. Marshes and artesian wells occurred at several localities along the trace of the fault and are said to have provided water for Native Americans and early settlers and missionaries. Groundwater in the Raymond Basin, north of Raymond Hill, is indicated by two Los Angeles county wells. These wells indicated water at a level of 164 to 173 ft. below ground surface in 1974 and 1999. These depths are about 9.8-19.6 ft. lower than was documented in the 1930s by (Conkling et al, 1934).

### **3.9 Subsurface Gas**

The Route 710 tunnel study area would not pass through any known operating or abandoned oil or gas fields or identified methane zones. The nearest active oil fields, the Boyle Heights and Union Station oil fields, lie approximately 2.9 and 4.1 miles southwest of the southern end of the assumed tunnel study corridor. No known tar or oil seeps occur along tunnel study area. However, discontinuous seams of lignite coal have been found within the Topanga Sandstone and occurrences of methane and natural gas have been noted throughout the Los Angeles Basin. Therefore, it should be considered possible that the tunnel may encounter gassy conditions south of the Eagle Rock fault. North of the Eagle Rock fault, it is not anticipated that the tunnel will encounter gassy conditions, as it will pass through quartz diorite and Quaternary alluvium.

### **3.10 Feasibility for Tunneling**

The ground conditions encountered in the 2006 drilling program generally confirmed the expected conditions at the drill locations. The current knowledge of ground conditions indicates that tunneling is feasible, given the cross sections studied. Present subsurface information is still too limited and additional investigation is necessary to fully characterize soil, rock and groundwater conditions for the entire corridor. The nature of the crystalline basement rock underlying the northern part of the corridor is still largely unverified. Future borings in the northern part should sample this rock and include at least one angled borehole to intercept the Eagle Rock fault to characterize the nature (age, orientation, etc) of the contact. Several angled borings will be necessary to characterize the nature of the folding, faulting, and the wide variety of rock types in the central area. One unexpected rock type was volcanic rock encountered in Boring 06-2 at a depth of about 142 to 152 ft depth.

A large part of the southern part of the corridor will be Fernando formation which is a stiff silty clay/soft claystone. Much of the remainder of the southern corridor is expected to consist of the Monterey formation which generally comprises soft rock of siltstone, claystone, shale, and sandstone. The engineering properties of the Monterey unit are unverified within the corridor but similar materials have been encountered in several tunnels in the Los Angeles region and it has been found to be suitable for tunneling. Future drilling will be needed to verify the engineering properties of the rock mass.

### 3.11 Additional Exploration and Testing

The geotechnical evaluation presented above is based on very limited subsurface information in the project area. Borings 06-1 and 06-2 drilled for this feasibility study have largely confirmed anticipated ground conditions and provide some basic soil/bedrock contacts and geotechnical engineering information as well as groundwater data in the vicinity of the boreholes. Additional investigation and studies will be required to better define key geotechnical, geological and seismological features of the project area. Present groundwater information is insufficient and additional groundwater measurements using piezometer installations will be required prior to any tunnel design and construction.

Considerable additional work may be required to characterize the York Boulevard, Raymond, and Eagle Rock faults and to develop the complex rock formation relationships near the fault zones. In the northern area in Pasadena, the geology and configuration of the Eagle Rock fault is not well understood. However, the abrupt changes between Borehole 06-3 and previous borings by Law/Crandall (1993) a short distance to the north suggest that there is a fault in the area as shown on published geological maps (e.g. Dibblee, 1989b). Future investigations should include angled borings to delineate and characterize the Eagle Rock fault and to characterize subsurface materials, particularly the crystalline basement rocks in the northern block. Such work should include determination of the extents and range of sizes of cobbles and boulders of which some fragments were found in the borings. In addition, the alluvial soils overlying the basement and the depth of soil/rock contacts and groundwater levels need further characterization for more detailed design. Recent boring 06-3 did not pass through a fault, suggesting that the fault is dipping northerly. Future borings should include at least one angled borehole to intercept the fault so the nature of the contact and its rate of activity can be characterized.

**(References: A full list of references has been included in the Study Geotechnical Assessment Technical Memorandum).**

## **4.0 Tunneling Technologies**

### **4.1 Introduction**

Feasible tunneling methods were evaluated considering the size of the Route 710 Tunnel cross-section, alignment of the tunnel, geologic and groundwater conditions, possible impacts on the adjacent structures and community, compatibility with final ground support, safety, and economy. This chapter reviews potential tunneling methods applicable to the tunnel as well as other associated underground structures such as shafts and cross-passages. It also addresses the ventilation requirements and identifies the technology assessed most appropriate to the conditions.

Tunnel cross-section requirements developed in this study range from about 38 feet to 57 feet diameter. A minimum of two tunnels (northbound and southbound traffic) would be required for the traffic volumes predicted. The sections required to meet traffic capacity requirements are discussed in Chapter 6. The options considered for tunnel configuration and alignment could be achieved by various construction methods given the cross-sectional area of the tunnel, length, and the ground conditions (described in Chapter 3).

### **4.2 Tunnel Conditions and Requirements**

#### **4.2.1 Horizontal Alignment and Controls**

The alignment of the twin or multiple tunnels would be controlled by such factors as traffic requirements, minimum highway curvature for the vehicle design speeds, and geometric constraints for the connections to the existing freeways and existing right-of-way. For a tunnel of the size required, the smallest curve radius that a Tunnel Boring Machine (TBM) can negotiate would be in the range of 1,000 feet. This would be one of the design criteria used to layout the horizontal alignment and is well within the horizontal curvature on the example alignment considered in determining feasibility under this study.

Twin or multiple tunnels would need to maintain a minimum horizontal separation of approximately one tunnel diameter along the alignment (about 50 feet) to prevent overstressing of the central rock or soil pillar due to redistribution of ground loads around the tunnels as they are excavated.

#### **4.2.2 Vertical Alignment and Controls**

The vertical alignment of the tunnel would be controlled by the approach elevations, highway standards for vertical curves, and the requirement to maintain sufficient cover over the crown. The vertical alignment establishes the tunnel cover and the hydrostatic pressure to be considered in the design, construction feasibility, and planning. Other considerations would be possible shaft locations and the presence of any interchange at Huntington Drive.



For this study, an effort was made to maximize the cover over the tunnel crown to reduce the potential for surface settlement and impacts on existing structures. A minimum cover of two tunnel diameters or 100 feet (assuming a 50 ft excavated diameter) was selected for the feasibility analysis. At the portals, where the roadway would approach the tunnels, shallower cover will likely be necessary for the transition into the assumed nominal 100 feet depth of cover of the main tunnel.

### **4.2.3 Tunnel Cross Sectional Requirements**

Figure 6-1, in Chapter 6, schematically illustrates cross sections assumed to accommodate four-lane tunnels in each direction, including allowance for shoulders and walkways – either to full highway standards or reduced standards. Depending on the final requirements for the cross section, the minimum excavated round tunnel diameter varies from about 38 to 57 feet, and in the oval or horseshoe-shaped tunnels spans of up to approximately 72 feet would be needed. The larger excavations would therefore need to exceed the size of the most recently constructed tunnels described in Chapter 2, but are comparable to the size of the M30 TBM-driven tunnels being constructed in Madrid, Spain, which has a 50 ft excavated diameter. For all of the sections studied, the excavated TBM tunnel diameter is over 38 ft and would be considered very large for a tunnel bored using current technology.

The excavated tunnel diameter has assumed about two feet of lining thickness for the structural support of the tunnel. The final thickness would be determined during more detailed design phases. Further discussion of tunnel lining and its installation is presented in this chapter.

### **4.2.4 Cross-passages and Shafts**

The cross-passages between tunnels are smaller diameter tunnels, linking from one main tunnel to the other and perhaps 20 ft in diameter. They would allow movement from one tunnel to the other to provide safe refuge from any incident in a tunnel tube. These additional cross tunnels would be driven using SEM methods (refer to 4.2.6.2), after the main tunnel has been excavated and lined. The assumption at this stage is that these would be at approximately 600 feet intervals along each tunnel in line with current practice and NFPA guidelines. (A closer spacing of 500 feet has been assumed for the options A2, B2 and C2 as there are 4 lanes of traffic and therefore more potential occupants to pass through the cross passage in this case.) In addition, safety refuges may also be formed into the walls of the main tunnels to provide space for refuge and emergency equipment.

### **4.2.5 Geologic and Groundwater Conditions**

Geologic conditions are of primary importance in planning tunnel construction methods. In tunneling terms, geology is generally termed “hard” or “soft” ground, for rock or soil conditions respectively. Design of the tunneling equipment, mining methods, and the ground support will be inter-related with the ground and groundwater conditions. For the Route 710 tunnel alignment, anticipated geologic conditions are summarized in Chapter 3, which includes an

initial schematic geological profile based upon the limited currently available ground information.

Conditions anticipated include relatively soft rock ('hard ground'), such as shales, sandstones, siltstones, and conglomerates, as well as alluvial soils ('soft ground') from more recent deposition. Groundwater conditions are not well defined at this point, but are not anticipated to be more than about 90 ft above the tunnel invert.

### 4.3 Tunneling Methods

In tunneling, it is critical that the face of the tunnel excavation and its full perimeter are tightly controlled to minimize ground losses, soil movement toward the tunnel shield and movements of the overlying ground and ground surface. For these reasons, the primary underground construction methods to be considered for the Route 710 Tunnel would be Pressure Face Tunnel Boring Machines. Other methods, such as the Sequential Excavation Method (SEM) may also prove effective, and warrant consideration for non-circular cross sections or short reaches for cross-passages and adits (due to the additional construction flexibility offered). At the portal sections, localized cut-and-cover methods might be required due to the minimal cover where the tunnel rises to the ground surface for the entrance.

#### 4.3.1 Tunnel Boring Machines

Based on the current limited data on geologic and groundwater conditions, the anticipated ground conditions could include a wide range of conditions, including hard rock, soft rock conditions, uncemented gravels and conglomerates and alluvial deposits. In the alluvium, soft and broken rock, the tunnel may encounter ground that ravel, runs, and flows depending on soil type and groundwater conditions. The need to minimize potential adverse effects of tunneling, and especially the need to minimize ground losses at the tunnel face, would require specialized methods to be employed for the tunnel construction. Some of the alternative mechanized and pressurized face machines currently employed for construction of tunnels in poor soils and under groundwater pressures are described below.



Figure 4-1 ECIS Project EPB Machine Being Assembled



Metro Goldline Eastside Extension TBMs at Manufacturing Plant (above)

### *Pressure Face Tunnel Boring Machines*

Pressure face machines (PFM), developed in Europe and Japan, maintain face stability and minimize ground losses by maintaining a positive pressure on the tunnel face in front of a pressurized bulkhead while the tunnel workers remain in free air (atmospheric pressure) within the machine but behind the bulkhead. The amount of ground excavated is controlled by means of a screw conveyor or a mechanical displacement pump.

Within the general term of PFMs, tunneling machines generally conform to two soft ground excavation principles or methods: the slurry face machine (SFM), and the earth--pressure balance machine (EPB). Several notable examples of uses of both of these technologies outside of the United States have been in Milan (EPB), Cairo (SFM), Madrid (EPB), Lyon (EPB), the Channel Tunnel (EPB), and several undersea tunnels in Japan (EPB, SFM). Locally, EPB machines were recently used to complete the 15.5 ft diameter East Central Interceptor Sewer and North East Interceptor Sewer (ECIS and NEIS) tunnels for the City of Los Angeles. The ECIS tunnels were completed in the fall of 2004 and the NEIS project is nearly completed. For the 21.5 ft diameter transit tunnels of the Los Angeles Metro Goldline Eastside Extension, two EPB TBMs have been fabricated and tunneling began in early 2006. (Figure 4-1)

### *Earth Pressure Balance Tunnel Boring Machines*

In a classical Earth Pressure Balance system, the cutting wheel operates within a chamber filled entirely with excavated ground. Face pressure is controlled by balancing the rate of advance of the shield with the rate of discharge of the excavated material through the screw conveyor. Figure 4-2 shows an EPB TBM cross-section and the pressure chamber and screw conveyor system. Material excavated through the cutter-head in an EPB system may need no treatment and emerges from the conveyor as a thick paste or ribbon that is emptied into waiting train (or a conveyor) for transport. Typical practice for EPB tunneling also includes the addition of bentonite, foams, and/or other conditioners into the pressure chamber and within the screw conveyor. The purposes of conditioning are to improve workability, modify permeability, improve the plasticity and reduce friction. EPB machines generally have been considered more appropriate in fine-grained (clay, silt and fine sand) material. While operating in stable ground, the pressure face mode may not be used.

EPBs have also been fitted with cutting discs to excavate through rock materials (including cobbles and boulders). Where geology changes along the tunnel alignment, as would be the case along the Route 710 tunnels, the cutting tools can be changed to some extent from the inside of the pressure chamber to suit the ground conditions encountered.

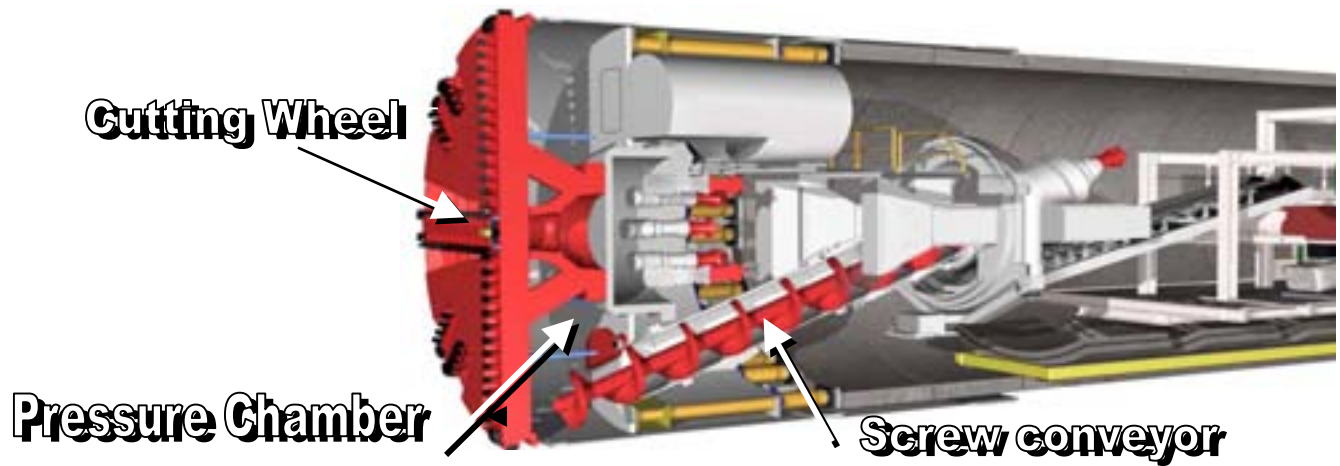

Figure 4-2 Section through Earth Pressure Balance TBM

#### *Slurry Face Tunnel Boring Machines*

The principle of the Slurry Face Machines (SFM) is to fill the excavation chamber with a mixture of soil cuttings and bentonite slurry fluid. This mixture provides the necessary ground support. Using the slurry return pipeline, the mixture of excavated material and slurry is taken to a separation plant where solids are removed and the treated slurry is returned to the heading. With the slurry system, face support and ground movements into and around the tunnel shield are controlled by maintaining a hydraulic pressure in the slurry that is equal to or slightly greater than the prevailing earth (soil and water) pressure. Figures 4-3 And 4.4 illustrate SFMs. Historically, SFMs have been considered more appropriate in coarse-grained (sands and cobbles) soil material. SFMs are currently being used in Portland, Oregon, for the Westside CSO project, and have also been ordered for Portland's Eastside CSO project. Similar to an EPB TBM, cutting tools for the SFM can be made interchangeable such that they can be adapted for ground conditions.

A "hybrid" TBM has been developed to be modified from EPB to SFM, and has been used where ground and groundwater conditions change dramatically along the alignment. For example, the A-86 highway tunnel in Paris, (referenced in chapter 2), is being constructed using the hybrid machine. Where conditions changed from soft rock to flowing sands, the EPB was changed to SFM within in the tunnel, over a period of about six weeks.

**Figure 4-3 Slurry TBM (spoil material pumped out in slurry)**

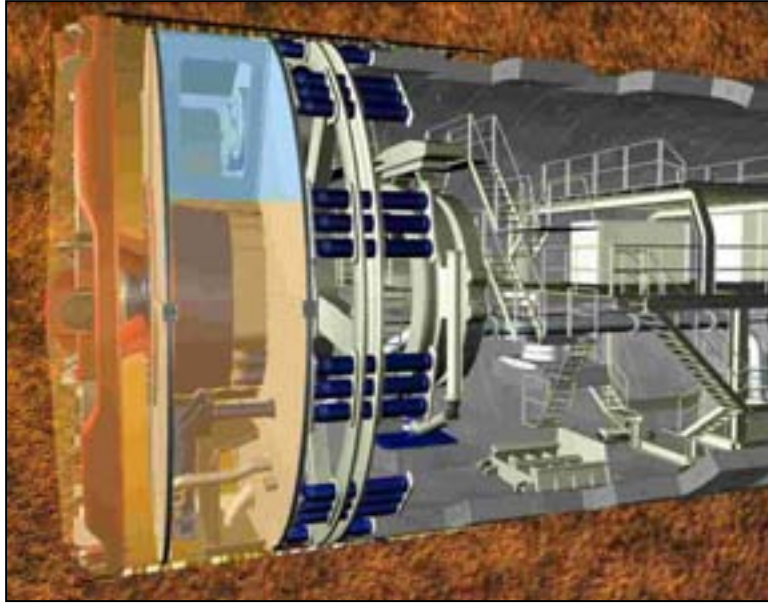

**Figure 4-4 Slurry Face TBM used for the 4th Tube, Elbe River Tunnel, Hamburg, Germany**



### *Tunneling Cycle*

Tunnel construction using either type of Pressure Face Machine (PFM) is a cyclic process consisting of advancing the tunneling shield into the ground, removal of the displaced ground into the shield and extraction of that ground (muck) from the pressure chamber with the screw conveyor or slurry system, and erection of pre-cast concrete tunnel lining segments. (Tunnel lining is further described below). The shield is propelled forwards by a series of hydraulic jacks mounted in the rear of the shield and reacting against the tunnel lining ring.

After the segmental lining is erected and fully bolted, the machine advances, and the annular space between the lining and the excavated perimeter is filled with grout through the tail skin and/or grout holes in the segmental lining. A special set of seals or brushes prevents the grout from flowing towards the shield and inundating the cutterhead. The segments themselves are bolted together and provided with gaskets to provide watertight joints.

### *Final TBM Selection*

Much more investigation of the tunneling conditions likely to be encountered is required before a decision on the most suitable excavation method can be made. It is typically the contractor, after evaluation of all the geotechnical data, overall project economics, and its preferred means and methods of tunnel support, who has the final recommendation for selection of the tunneling method, and for the design, operation, and choice of the tunnel excavation system.

### *Groundwater Control – TBM Tunnels*

Dewatering is not required in tunnel construction that uses a mechanized, pressure-face TBM to counterbalance the hydrostatic pressure and stabilize the soils. The Route 710 Tunnel will be under a head of up to approximately three bars pressure in some locations with a significant difference (approximately one bar or 290 pounds per square foot) across the face of the large diameter tunnel boring machine. These pressures must be accounted for in the design of the TBM bearings, seals, and all other machine systems, components, and auxiliary equipment. Relatively speaking, the groundwater pressure for the 710 tunnels would not be considered high.



**Figure 4-5 Precast Segmental lining for A-86 Tunnel, France**



### *Tunnel Ground Support*

Behind the TBM a support system is required to maintain the safety and stability of the opening during construction and for the service life of the structure. The most practical lining system consists of a system of pre-cast concrete segments assembled within the TBM shield. Figure 4.5 shows a photo of a bolted segmental tunnel lining. These pre-cast segments serve as the final tunnel lining and are designed, fabricated, and installed with tight tolerances. Specially constructed rubber gaskets provided along the sides of each segment can essentially eliminate water inflows. Used with the PFMs, tunneling can be accomplished under water without the need for prior de-watering.

### **4.3.2 Sequential Excavation Methods**

Recognizing the inherent variability of geologic conditions and variable tunnel cross-sections methods have been developed to approach tunneling so that the method of excavation and support can be varied to suit conditions as they are actually encountered.

One of these methods is the Sequential Excavation Method (SEM). The term may also be used interchangeably with “NATM” (New Austrian Tunneling Method) or simply, “mined” tunnels. The method is founded on careful observations of the ground response to excavation using instrumentation and visual inspection. This allows timely adjustments in excavation and support

details in response to these observations. Typical SEM excavation sequences are shown in Figures 4.6 and 4.7.

This method may not be appropriate for very large openings in relatively soft ground. For example, any ramp intersections for an underground interchange at Huntington Drive – along with the wide mined tunnel option would require a mined span in soft rock of over 100 ft. This appears to be too large to accomplish using SEM.

Generally, SEM is applied for large non-circular tunnels in soft ground where the stability of the opening requires that support be applied rapidly, or for short tunnels where fabricating a machine is not economically practical. SEM usually involves a combination of the following components:

- Heading and bench or multi-drift excavation – Figure 4.6 illustrates numbered drifts for excavation sequence with dowel and shotcrete support around the perimeter;
- Excavation by mechanical means, sometimes with blasting in hard rock. Mechanical means often include roadheaders, or demolition hammers;
- Initial ground support usually consisting of rock reinforcement and shotcrete (sprayed on concrete) installed within minutes after the rock is excavated;
- Forepoling or spiling (placement of closely spaced rows of drilled or driven pipes and grouted dowels around the tunnel perimeter); may be added;
- Stabilizing the face temporarily, using shotcrete;
- Ground improvement using grouting, freezing or dewatering as necessary;
- Extensive use of monitoring to ascertain the stability and rate of convergence of the opening; and
- Importance of instantly changing mix of components as indicated by measurements and observations.

Variations on sequential methods would include techniques such as the “stacked drift” method where the tunnel perimeter lining is placed ahead of the excavation using a series of smaller tunnels in a ring shape (Figure 2-5). This method is generally more appropriate for relatively short lengths of tunnel in soft ground.



**Figure 4-6 Typical SEM Excavation Sequence – with Dowels Around Circumference**

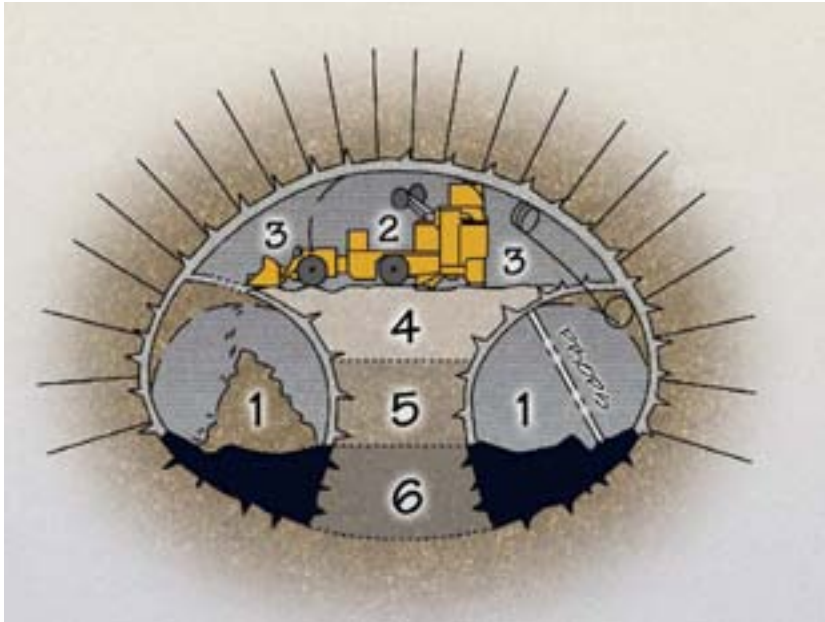

**Figure 4-7 SEM Construction**



**Left – SEM Portal Excavation, Right – Tunnel Drifts Excavated Using SEM**

The tunnel section is developed in a staged series of smaller headings in a defined and controlled pattern and work sequence. The smaller headings allow excavation and support of smaller portions of the tunnel ground, thus providing greater control of movements and the ability to support the ground more quickly. The final lining usually consists of additional shotcrete or cast-in-place concrete, often with a waterproofing membrane between the initial ground support and the final lining. Excavation equipment used in SEM construction includes roadheaders in

softer rock conditions such as those present in the study area. (Figure 4-8 shows a roadheader). Progress, or rate of advance, for large SEM tunnels may be considerably slower than for a mechanically (TBM) excavated tunnel. In some cases the rate of advance may be offset by adding headings (tunneling from more than one face), and a very short lead time to start tunneling (as a TBM does not need to be fabricated).

A fundamental element of the SEM method is its extensive reliance on instrumentation and monitoring for immediate feedback during construction to determine the time rate and magnitude of ground movements both around the lining perimeter and, especially for shallower tunnels, at the ground surface. Through deformation monitoring, an assessment can be made about the stability of the opening and the adequacy of the installed support elements. If the deformation and/or loads are increasing then additional support and/or modified heading operations are implemented immediately to stop the deformations. The final lining is placed only after the instrumentation shows that ground movements have stopped. SEM requires careful execution especially in weak or poor ground and is generally performed by crews that are well experienced in this work.

**Figure 4-8 Roadheader for Tunnel Mining**



### 4.3.3 Fault Crossings

Faulted ground would be considered for additional investigation, both for potentially active fault characterization, as well as for blocky (less stable) tunneling conditions. The major fault crossing along the alignment is the Raymond Hill Fault. As described in Chapter 3, the fault has been characterized as having a left-lateral oblique reverse slip. This fault dips at about 75 degrees to the north. Between the York Boulevard and Raymond Hill Faults is an approximately 500-m wide zone of localized, high-angle shearing and deformation. Ground is expected to be ranging from highly fractured to crushed with seams of clay gouge. While additional study is required to characterize the fault in the location of the Route 710 tunnel crossing, feasible

construction methods for a fault crossing could include SEM using multiple drifts and specialized support, such as ground treatment through grouting, or TBM driven tunnels.

The Los Angeles Metro Red Line tunnels were constructed through the Santa Monica Fault zone. Geotechnical investigations for these tunnels were conducted to characterize the rock mass along the alignment and such major fault structures as the Hollywood and Benedict Canyon Faults. As a result of the investigations, the tunnel was characterized on the basis of ground conditions and divided into reaches with different initial ground support systems. Initial support varied from rock bolt support to steel ribs. Seismic design for the Santa Monica Fault crossing included an oversized, mined tunnel section to facilitate repair in the event of fault displacement. The mined section was constructed using SEM with shotcrete (sprayed-on concrete) and steel lattice girders as final support.

#### **4.3.4 Underground Ventilation Buildings and Shafts**

Deep excavation construction methods may be used for underground ventilation buildings at the portal areas and mid-point, and for any shaft construction. For these structures, the excavation's initial support systems could include reinforced concrete drilled-in-place piles, soldier piles and lagging, and tied-back excavations. Initial support allows support of the ground while soil is removed from the interior excavation. Final support includes the concrete slabs, walls, and walkways.

Current information for the Route 710 portal areas indicates that the portal areas are above the groundwater table. However, conditions are not well defined. If water is present at these or other cut and cover or open cut structures, de-watering may be required to temporarily lower the groundwater level below the excavation depth or to an impermeable soil layer. Dry excavations facilitate installation of the piles, improved soil stability, and reduced pressure. Groundwater is pumped from wells installed around the perimeter of the excavation. At the completion of the structure, pumping is discontinued and groundwater levels are allowed to return to their natural levels.

To install piles and lagging for support of the excavations, it is generally necessary to auger out the holes for the placement of the piles. This pre-drilling of holes is necessary to eliminate pile driving and reduce project noise and vibration levels that would otherwise occur with pile driving. The equipment required for installation of the soldier piles includes drill rigs, concrete trucks, cranes, and dump trucks. After installation of soldier piles the contractor would proceed with installation of excavation bracing and lagging.

As an alternative to dewatering, soldier piles and lagging, impermeable walls such as slurry walls or closely spaced pile may be constructed to provide a groundwater barrier. Often these structures are incorporated into the final structure.

#### **4.3.5 Hauling of Soil**

The methods of removing the spoil materials for hauling away from the job site is a generally a choice made by the contractor, but may also be subject to conditions stated in the environmental

documents. For tunnel operations, much is removed at the portal areas using hoppers and/or conveyors and generally trucked to a disposal area. For cut and cover construction, a typical operation would be for bulldozers and/or overhead loaders to move the material to a central pickup point or several such points, where a clam shell bucket from a crane or a vertical or diagonal conveyor belt can hoist the material and place it into waiting trucks or a loading hopper.

#### 4.3.6 Protection of Adjacent Structures

Geologic conditions for portions of the alignment are sands, clays and gravels. As described above, during tunneling, some ground loss will occur, producing surface settlement. The amount of settlement measured at the surface will be a function of the tunnel depth, size, tunneling equipment and techniques, and geology. To reduce surface settlement and the potential for ground loss and soil instability (sloughing, caving) at the tunnel face, pressure-face TBMs and pre-cast, bolted, gasketed lining systems would likely be employed. In combination with the face pressure, grout is installed immediately behind the TBM between the installed precast concrete liners (tunnel rings) and the ground. The pressure-face TBM can tunnel below the groundwater table without requiring dewatering or lowering of the groundwater table.

During design of the project, buildings and other structures along the alignment would be evaluated considering the local geology, their proximity to the tunnel or open cut section and the tunneling methods to be employed. In some cases additional settlement mitigation could be recommended. All buildings within the tunnel's potential zone of influence would be initially surveyed and then monitored during tunneling to verify that ground movements do not exceed allowable limits.

Where conditions warrant, for example, where shallow tunnels are closer to the surface and directly below sensitive structures or utilities, additional methods to reduce settlement could be specified. These could include:

*Permeation grouting* to improve the ground prior to tunneling: Chemical (sodium silicate) or cement grouts are injected into the ground to fill voids between soil particles – typically sandy soils - and provide greater strength and stand-up time for the soil. This grout can be placed through pipes from the surface before the tunnel reaches the grouted area, from pits or shafts adjacent to the grouted area, or in some instances from the tunnel face. In this latter case, the tunneling machine must be appropriately equipped with drills and valves and must be stopped for a period of time to drill grout placement pipes, install grout, and allow the grout to set. The permeation grouting method has been used successfully for the Metro Red Line in instances where the tunnel passed under potentially sensitive or important structures such as the US 101 Freeway (at three locations: Downtown, Hollywood and at Universal City).

*Compaction grouting* as the tunnel is excavated: This method involves injection of a stiff “grout,” typically sand with small amounts of cement, above the tunnel crown as the tunnel advances. The grout densifies soil above the tunnel crown and replaces some of the lost ground, and thereby prevents settlement from propagating to the surface. This method was successfully used in several instances for the Metro Red Line project in the downtown Los Angeles area.

*Compensation Grouting:* Compensation grouting involves carefully controlled injection of grout between underground excavations and structures requiring protection from settlements. For tunnel applications, the pipes for grouting are installed above the intended tunnel position, in advance of tunneling. A key component in controlling compensation grouting is careful monitoring of both structure and ground movements to allow the timing and quantities of injected grout to be optimized. Grout injection can take place before, during, and after tunneling activity by reusing the same grout pipes.

*Underpinning:* Underpinning involves re-supporting the structure's foundation on ground that will not be influenced by the tunneling. This may not be feasible where the structure is directly over a large tunnel.

#### **4.3.7 Instrumentation and Monitoring**

As part of the measures for protecting buildings, structures and utilities from the effects of tunneling, instrumentation to monitor ground movements and settlements would be employed. The geotechnical monitoring will establish:

- Baseline conditions prior to tunneling or start of open cut excavations.
- Ground movements and building settlements caused by each tunnel as it approaches and passes under beyond each monitoring station or facility
- Ground movements and building settlements caused by open-cut excavation as it proceeds downwards and until the final structure is completed.
- Confirmation that settlement effects due to construction has stabilized.

To establish a baseline for assessment of actual damage resulting from tunnel construction, pre-construction surveys of all private and public structures, including utilities would be conducted. These surveys would include a visual record of cracks and other pre-existing signs of distress or damage. After tunneling has passed, structures would be re-inspected for any damage and the extent of damage caused by tunneling or surface excavation would be assessed.

#### **4.3.8 Summary**

Given the numerous types of structures (main tunnels, cross-passages, shafts, portals, and adits) and limited current knowledge of variations in ground conditions, a number of feasible methods, described above are currently available for the project. Depending on the final tunnel diameter, a bored tunnel, as opposed to one constructed using SEM, may not be feasible today if the excavated diameter is greater than about 56 feet. Final selection of means and methods would entail final geotechnical investigations and tunnel design and economic analysis, and consideration of continuing advances in tunneling technology. During future phases of project development the project team can analyze the project geology and functional tunneling requirements and analyze available alternatives for consideration. This project would take place

in the future and it is anticipated that technology advances would allow even larger diameter tunnels to be considered.

#### **4.4 Tunnel Ventilation**

Ventilation is required to maintain a safe, comfortable environment during normal operation of the road tunnel, with several factors considered:

- Safe levels of vehicle-emitted pollutants such as carbon monoxide (CO) and oxides of nitrogen (NO<sub>x</sub>) must be maintained.
- Visibility must be maintained for safe driving.
- A tenable environment must be maintained for motorists escaping a fire emergency.
- Temperatures must be maintained at acceptable levels.

In short tunnels, the air pushed through the tunnel as a result of vehicular movement (piston-effect) is sufficient to maintain safe levels of contaminants. Fresh air is brought in through the entrance portal and contaminated air is forced out through the exit portal. During congested traffic conditions the piston-effect may not be sufficient. Tunnel ventilation must then be employed to maintain a safe tunnel environment.

One of the main functions of a tunnel ventilation system is to provide a means for controlling smoke and heat movement during a fire emergency. In the case of a fire in a tunnel serving unidirectional traffic, it may be assumed for a limited access highway that the traffic ahead of the fire would proceed to the exit portal and the traffic behind the fire will come to a stop. Therefore, the ventilation system would be operated to force the smoke and hot gases in the direction of the empty tunnel. Thus, a clear and safe environment behind the fire is provided for evacuating people and fire fighter access to the incident. The ventilation system accomplishes this objective by preventing the development of a smoke backlayer, so that occupants of the halted vehicles may then escape back down the tunnel away from the fire, without being engulfed by the smoke backlayer. Backlayering is the movement of smoke and heated gases back over the vehicles stopped behind the fire in the presence of a controlled longitudinal airflow attempting to push the heat and smoke away from the stopped vehicles.

##### **4.4.1 Ventilation System Types**

Tunnel ventilation methods are categorized as either natural or mechanical systems. Natural systems rely on the piston-effect of moving vehicles, external wind, and temperature and pressure differentials between the portals to generate airflow through the tunnel. Mechanical systems use fans to generate airflow. There are several types of mechanical systems which are typically classified as longitudinal, semi-transverse or transverse.

Longitudinal systems have air introduced to a tunnel or removed from a tunnel at a limited number of points, such as at portals or at ventilation shafts. A popular example of this type of

system employs ceiling-mounted jet fans (Figure 4.9) to produce the required airflow through the tunnel. Longitudinal systems are typically used in tunnels with unidirectional traffic to take advantage of the vehicle piston effect.

Semi-Transverse systems use an air duct to either supply or remove air uniformly along the length of a tunnel. The supply system is the more widely used type, since it provides more uniform dilution of pollutants throughout a tunnel. In this configuration, reversible fans are typically used to provide for smoke exhaust.

Transverse systems use both a supply and an exhaust air duct to uniformly distribute air to and from a tunnel. Typically, air is supplied low near the roadway level to promote the rapid dilution of the vehicle-emitted pollutants. Air is exhausted along the tunnel ceiling which is advantageous for exhausting hot smoke in the event of a vehicle fire.

For this study, a longitudinal ventilation system was considered as the Route 710 tunnel will serve uni-directional traffic and a longitudinal system should keep ventilation costs at a minimum, while maintaining adequate ventilation.

#### 4.4.2 Air Cleaning Technology

Though air cleaning technology is currently in use in a few road tunnels around the world, air cleaning is still an emerging technology and has not been used in any tunnel in the United States. Vehicular emissions are typically dispersed into the atmosphere through high ventilation exhaust stacks, if required. It is important to note that California emission controls are among the most stringent in the world and continue to be improved to provide better ambient air quality throughout the region. Air cleaning systems have recently been introduced to try to address particular air quality problems in tunnels where vehicle fleets and emissions are very different from California, and these are to date largely unproven in operation. Use of air cleaning technologies would require acceptance by the Federal Highway Administration (FHWA) as well as the South Coast Air Quality Management District (SCAQMD).

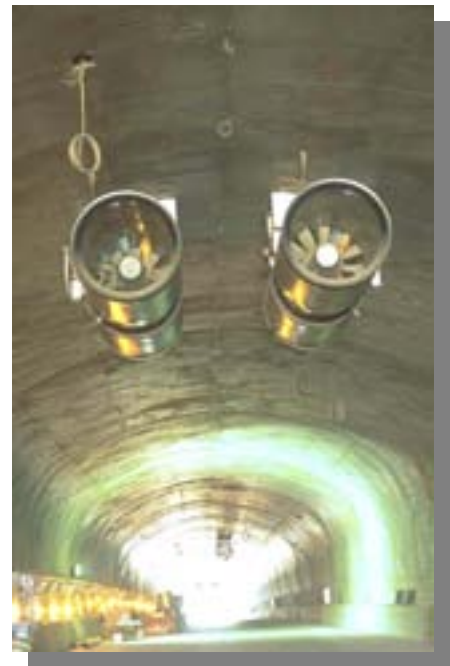

**Figure 4-9 Longitudinal Ventilation with Jet Fans**

Air cleaning systems have been used for removing particular emission contaminants, but they do not clean all polluting elements. Currently the only established technology for air cleaning is electrostatic precipitation. Electrostatic Precipitators (ESP) have been used in some other countries around the world and have been shown to be an efficient and viable technology for cleansing air of Particulate Matter (PM). They have been developed to remove dust and PM arising from the high level of diesel emissions in the vehicle fleet. They were developed in Japan for example, where diesel vehicles comprised some 40 per cent of the vehicle fleet. In



Scandinavia, they were introduced to clean tunnel air of high levels of dust that arose due to the use of studded winter tires which broke down the asphalt surfaces within tunnel leading to visibility problems. In Australia, they are currently being considered, where public concern over emissions resulted in their use on some recent tunnels again with a higher proportion of diesel vehicles in the tunnels.

However, in many cases ESPs have been found not to be in use or only used in certain conditions. The power required to operate the ESP's is very significant and may require additional generation capacity to be developed elsewhere to meet the power demand (estimated at 50-60 kW of power). The ESP installations have significant space requirements that may not be easily accommodated. Also the ESP give rise to a disposal issue for the wash solutions used to clean the precipitator plates and require additional environmental controls for handling the contaminants. Even if the next steps of the tunnel concept proceed today, the Route 710 tunnel would probably not be open to traffic for at least another 15 years and the design of the ventilation system would need to take account of the anticipated improvements in local vehicle exhaust emissions and applicable changes in air quality standards along with any technological advances that may occur in 'scrubber' systems over that time. Nevertheless, since ESPs have some beneficial effects and is an emerging technology, it is warranted that future stages of the project include additional studies of existing ESP system and the like.

#### **4.4.3 Tunnel Alternatives**

For this initial ventilation analysis, the tunnel has been assumed to be approximately four miles long with four lanes of unidirectional traffic in each direction. The ventilation requirements for the nine different tunnel alternatives to be identified in Chapter 6 were initially evaluated to assess feasibility. The tunnel cross section for each alternative is shown in Figure 6.1.

#### **4.4.4 Criteria**

The following relevant in-tunnel criteria relating to different factors used in ventilation design, were used for this initial analysis:

- Carbon Monoxide: Environmental Protection Agency/Federal Highway Administration (EPA/FHWA) criteria require that CO levels not to exceed 120 ppm.
- Nitrogen Oxides: World Road Congress (PIARC) criteria require that NO<sub>x</sub> levels not to exceed 10 ppm.
- Visibility: Visibility shall be maintained so that a light beam passing through 328 feet shall have greater than 50 percent of the emitting intensity. Visibility is also related to light extinction. These are again PIARC criteria.
- Heat: Vehicles generate heat. In long road tunnels the heat buildup in the tunnel may result in an extremely uncomfortable environment and that in an extreme case may be hazardous to the tunnel users. The National Fire Protection Association, NFPA 130 "Standard for Fixed Guideway Transit and Passenger Rail Systems 2003 Edition" publishes guideline criteria. For this study, a peak temperature of 95°F (Ambient + 5°F) was used.



- **Fire Emergency:** During a fire emergency the direction of smoke movement should be controlled by preventing “back-layering”. The air velocity required to prevent back-layering is called the “critical velocity”. The critical velocity varies dependant upon tunnel cross-sectional area, height and grade, and fire heat release rate. The critical velocity equations are presented in NFPA 502.
- **Air Velocity:** NFPA 502 requires that the longitudinal air velocity in the tunnel must not exceed 2200 fpm during emergency conditions. Excessive tunnel air velocities may produce extreme equipment power requirements for normal operations and should be avoided.
- **Particulate Matter:** There are no PM requirements specific to tunnel emissions and short term exposures experienced by tunnel users. Since the exposure time to PM10 and PM2.5 is minimal and there are no published short-term standards for PM10 (or the intent to publish such standards), this criterion is considered to be of no concern within the tunnel. The World Road Congress (PIARC) has published a methodology that relates visibility levels to PM10. Therefore this methodology was used in the analysis. Outside of the tunnel, atmospheric dispersion aided by ventilation stacks will manage concentrations of PM to appropriate levels.
- **Toxic air pollutants, also called air toxics,** are those pollutants that cause or may cause cancer or other serious health effects. Diesel Particulate Matter (DPM) has been identified as a Toxic Air Contaminant (TAC) by the California Air Resources Board (CARB) and DPM is considered a TAC under California’s air toxics program. DPM is a complex mixture of thousands of gases and fine particles (commonly known as soot) that contains more than 40 toxic air contaminants. These include many known or suspected cancer-causing substances, such as benzene, arsenic, formaldehyde, and nickel. For TAC, cancer risk thresholds, rather than emission burdens, are used to determine the significance of a project impact. The cancer risk threshold according to CARB is measured by continuous exposure over a 70-year period. Therefore, in-tunnel exposures are not of concern within the tunnel, but the resulting concentrations outside the tunnel would require investigation.

Should the tunnel be built, tunnel monitoring may be required for PM10, PM2.5 and DPM may be required to examine the degree of the emissions from the tunnel portals and the mid-point ventilation stack(s). The ventilation stacks will require design that considers the portal and stack concentrations with respect to ambient concentrations and allows these to be reduced to acceptable levels, so that they are not a concern. A full dispersion analysis would be required, and this would include consideration of local wind, climate and topographical effects.

#### **4.4.5 Analysis Approach**

The initial feasibility analysis followed these steps with the assumption of a longitudinally ventilated tunnel:

- Using the entire length of the tunnel, the air velocities required to meet criteria were determined.

- If the air velocities determined for the tunnel length were excessive, the air velocities required to meet criteria for a 12,000-ft long tunnel was determined. 12,000 ft was selected due to the uncertainty in the location of a mid-tunnel ventilation building.
- If the air velocities determined for a 12,000-ft long tunnel were excessive, the air velocities required to meet criteria for a 6,000-ft long tunnel was determined.
- Once ventilation requirements were determined, the ventilation building required to house ventilation equipment was sized.

This approach was used for each of the nine tunnel cross-section alternatives.

#### 4.4.6 Analysis

The analysis covered the airflow requirements for CO, NO<sub>x</sub>, Visibility, Heat, Fire Emergencies and Velocity criteria. Analysis results for each of these criteria are summarized below. With respect to velocity criteria, each of the contaminants requires a volume of airflow for control and the airflow translates to air velocities depending on the tunnel cross-sectional area.

Emissions and fuel usage data is based on a design year of 2015 and is taken from the California Air Resources Board (CARB) program EMFAC, which is an On Road Emissions Inventory Model that presents data specific to California highways.

The typical passenger car unit (pcu) represents an average car that uses the tunnel. Emissions estimates and other vehicle properties such as pcu length were based on the following traffic blend:

- 87.8% Light Duty Automobiles
- 4.0% Light Duty Trucks
- 1.1% Medium Duty Trucks
- 7.1% Heavy Duty Trucks

For the purposes of this analysis, the typical passenger car unit (pcu) was assumed to be bumper to bumper throughout the tunnel.

The following conclusions can be made with respect to the ventilation analysis:

- Tunnel heating is a significant ventilation issue. Tunnel temperature must be monitored and mechanical ventilation sized accordingly. The severity of tunnel heat is directly dependent upon the actual tunnel usage once it is in operation. In reviewing the simulations with respect to heat, it is evident that larger cross-sections are more conducive to maintaining lower ventilation air velocities. Based on this analysis, Alternatives C1, C2 and C3, which have the smallest diameters (see Chapter 6 for descriptions of alternatives, would likely need significant control of traffic volumes.
- CO and NO<sub>x</sub> are not significant ventilation issues in this case, due to low vehicle emission reports from EMFAC 2002.

- Visibility must be monitored, but the predicted airflows required to maintain visibility are minimal, and are unlikely to control the design solution.
- Critical Velocity must be met during fire conditions. The airflows required to control smoke “back-layering” represent the absolute minimum ventilation requirement and ranged between 590 and 678 fpm in this initial analysis.
- Air velocities can be maintained under 1000 fpm, except for the instance of tunnel heating.

#### 4.4.7 Ventilation Installation

The ventilation analysis showed that a mid-tunnel exchange of air is required. Therefore a mid-tunnel ventilation building is needed with air ducts to the tunnel below to facilitate the removal of contaminated air and the introduction of fresh air. The mid-tunnel shaft connection to the tunnel should be within 1500 feet of the tunnel mid-point. The mid-tunnel ventilation building could be offset from the centerline of the tunnel. This would require lateral shafts connecting the building to the tunnel. If the site for a mid-tunnel ventilation building is environmentally sensitive or mechanically warranted, this could result in more than one ventilation building being required at appropriate locations along the alignment.

A longitudinal ventilation concept using Saccardo Nozzles is proposed for this tunnel. In this ventilation concept, air is directed toward the exit portal with sufficient force and velocity to generate a longitudinal airflow in the tunnel. All the supply air is delivered to the roadway through a large slot in the ceiling or in the tunnel walls. The longitudinal airflow would also push smoke and heat toward the exit portal, thus providing protection to motorists stopped behind the fire incident. A schematic of how a Saccardo Nozzle system works at the portal is shown in Figure 4-10. In addition, a schematic of how a Saccardo Nozzle system works at any mid-tunnel location is shown in Figure 4-11. These indicate an arrangement for the single deck tunnel options and it could be modified for a double deck configuration also.

A Saccardo Nozzle longitudinal ventilation system should not require the use of mechanical ventilation equipment in the tunnel. Thus the fans, electrical equipment and other appurtenances required to run the tunnel ventilation system are located in a ventilation building where maintenance can be accomplished without interrupting traffic flow.

The ventilation building may be placed entirely underground except for the ventilation stack. At this stage, without a dispersion analysis, the exhaust stack is estimated at 100 feet height above ground. The analysis would be required during future stages of the project, once the tunnel location and traffic data were more precisely known.

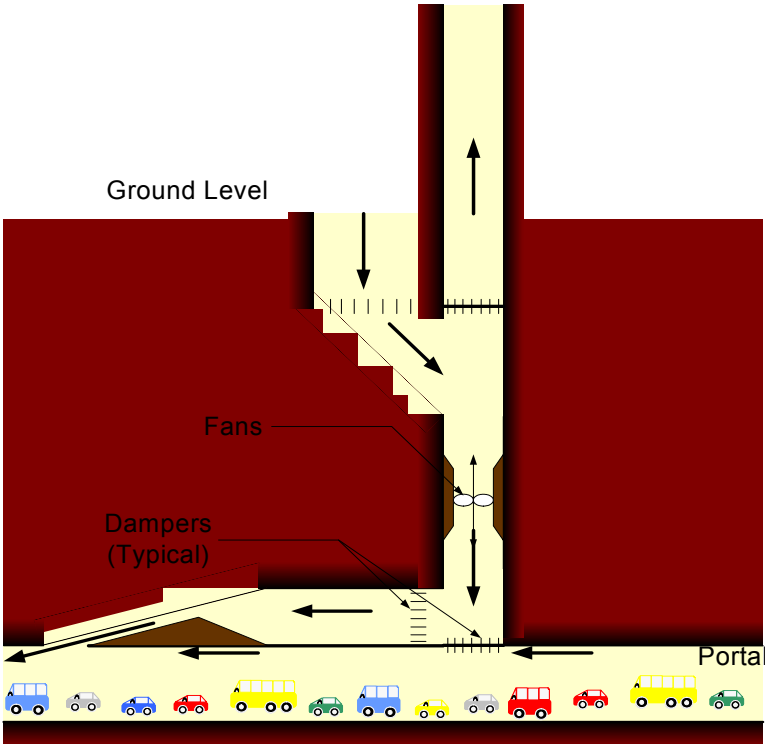

Figure 4-10 Example of a Portal Building Ventilation Arrangement for Longitudinal Ventilation using a Saccardo Nozzle

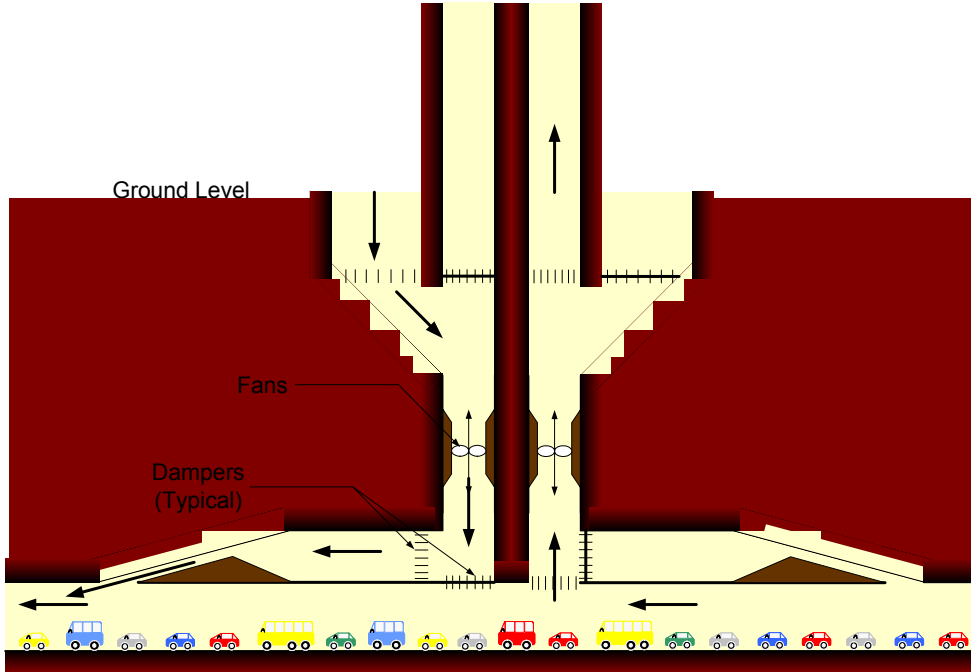

Figure 4-11 Example of a Mid-Tunnel Ventilation Arrangement for Longitudinal Ventilation using a Saccardo Nozzle

## 5.0 Traffic Modeling / Traffic Analysis

### 5.1 Introduction

The traffic analysis associated with the Route 710 Tunnel Feasibility Technical Assessment had the following objectives:

- To ascertain the adequacy of the three- and four-lane per direction tunnel alternatives to accommodate projected traffic conditions, and
- To understand the changes in traffic patterns expected on the arterial streets and freeways in the vicinity of the proposed Route 710 tunnel.

The Southern California Association of Governments (SCAG) Year 2030 Transportation Model was used to forecast traffic volumes associated with the alternatives.

### 5.2 Scope and Limitations of the Traffic Analysis

Commensurate with the conceptual nature of the feasibility study, the traffic analysis is intended to provide rough order of magnitude (ROM) estimates and preliminary guidance regarding the adequacy of the tunnel alternatives to accommodate anticipated traffic volumes.

The traffic analysis is also intended to provide an overview of changes in traffic pattern associated with the Route 710 tunnel that can be expected on freeway segments and arterial streets.

The traffic analysis performed at this conceptual stage is not intended to be a detailed travel demand forecasting effort, or a traffic/transportation impact analysis typically performed during the environmental phase of projects.

### 5.3 Scenarios Analyzed

Table 5-1 summarizes the scenarios included in the traffic analysis. The 2030 Baseline traffic volumes without the gap closure were obtained from the Model. Six tunnel alternatives were modeled to compare against the Baseline forecast.

**Table 5-1 Route 710 Gap Closure Alternatives Analyzed**

Gap Closure Configuration	With Huntington Drive Interchange (HDI)		Without Huntington Drive Interchange (HDI)	
	With Trucks	No Trucks	With Trucks	No Trucks
3 lanes / dir	Scenario 2	Scenario 4	Scenario 3	Scenario 5
4 lanes / dir	Scenario 6		Scenario 7	

Scenarios 2 through 5 assume gap closure alternatives with twin one-way tunnels with 3 lanes in each direction. Scenarios 6 and 7 assume twin one-way tunnels with 4 lanes in each direction. The following variations were analyzed between these scenarios:

- Scenarios 2, 4 and 6 assume an interchange at Huntington Drive; Scenarios 3, 5 and 7 are analyzed without the interchange.
- Scenarios 2, 3, 6 and 7 assume both auto and truck traffic will be permitted to use the tunnel; Scenarios 4 and 5 are analyzed with auto-traffic only.

#### **5.4 Route 710 Tunnel Traffic Volume Forecast**

Automobile and truck traffic volume forecasts for each scenario were obtained from the SCAG 2030 Model. For the purposes of capacity analysis, a Passenger Car Equivalency factor of 2.5 was used to convert truck-volumes to Passenger Car Equivalents (PCE). The analyses presented in this report are in terms of PCE. Auto and Truck traffic volumes are presented in tables in the Appendix.

##### **5.4.1 2030 Average Daily Traffic (ADT) Volumes**

For scenarios that include the Huntington Drive Interchange, traffic volumes in the segment south of the Interchange are projected to be up to 35% higher than those in the segment to the north of the interchange. This observation reflects a significant need to augment the capacity of arterial roads in the vicinity of the interchange. The southern segment ADT volumes vary between 75,000 PCE for the 3-lane Scenario 5, and 113,500 for the 4-lane Scenario 6.

Figure 5-1 illustrates and summarizes the ADT volumes by gap-closure segment and direction for the six tunnel scenarios.

##### **5.4.2 2030 AM Peak Hour Traffic Volumes**

During the AM peak hour, southbound traffic volumes are significantly higher than northbound traffic volumes. In the southbound direction, AM peak hour traffic volumes vary from 6,500

Figure 5-1 2030 Route 710 Tunnel Average Daily Traffic (in PCE)

**2030 ROUTE 710 TUNNEL AVERAGE DAILY TRAFFIC (in PCE)**

	Northbound		Southbound	
	S/o HDI	N/o HDI	S/o HDI	N/o HDI
Scenario 2	106,760	80,650	103,390	85,260
Scenario 3	79,750	78,750	81,220	81,220
Scenario 4	96,600	71,810	91,560	75,730
Scenario 5	75,240	75,240	75,850	75,850
Scenario 6	113,440	82,730	106,650	86,370
Scenario 7	86,220	86,220	86,220	86,220

HDI = Harrington Drive Interchange

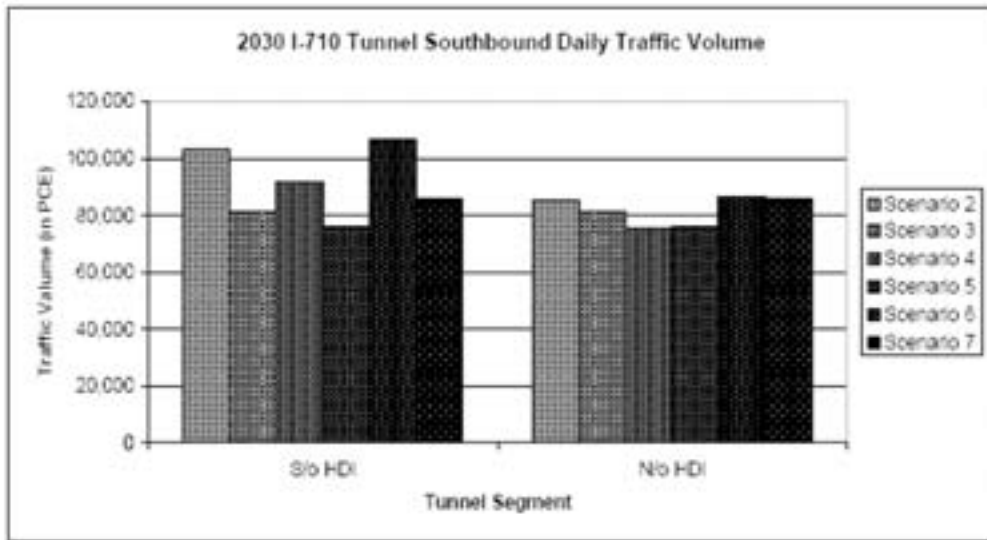
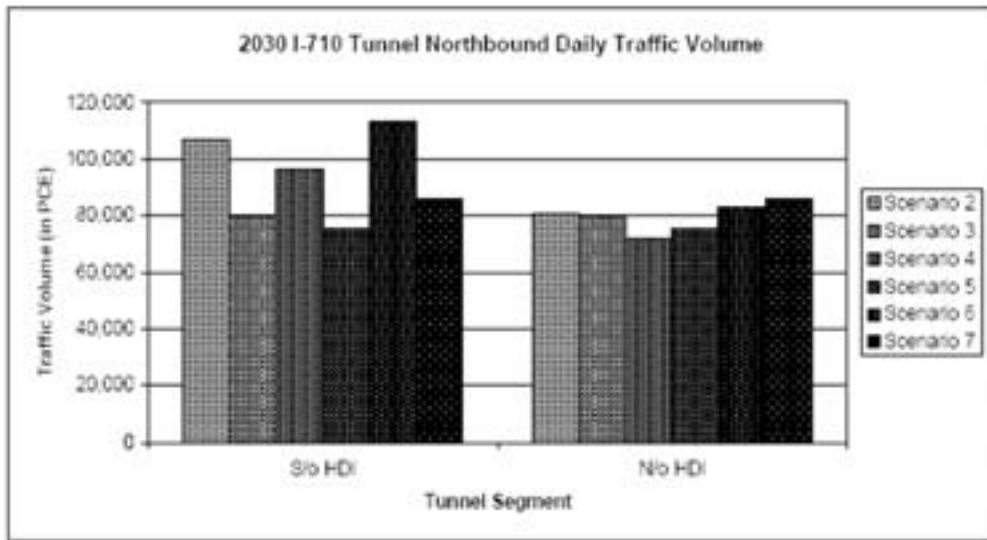

PCE for the 3-lane Scenario without trucks and Huntington Drive Interchange, to 9,000 PCE for the 4-lane Scenario 6 with trucks and with the interchange.

Figure 5-2 illustrates and summarizes the AM peak hour volumes by gap-closure segment and direction for the six scenarios.

### 5.4.3 2030 PM Peak Hour Traffic Volumes

Northbound traffic volumes are higher than southbound volumes during the PM peak hour, and vary from 6,400 PCE for the 3-lane Scenario 5 to 9,750 PCE for the 4-lane Scenario 6. Figure 5-3 illustrates and summarizes the PM peak hour volumes by gap-closure segment and direction for the 6 scenarios.

## 5.5 Gap-Closure Capacity Analysis

The ability of the gap-closure segments to accommodate peak-hour/peak-direction traffic was analyzed for each scenario. The analysis was conducted for the PM peak hour, since it was projected to be more critical than the AM peak hour. In the scenarios where the Huntington Drive Interchange was incorporated, the traffic volumes in the southern segment (between the south portal and Huntington Drive) were found to govern the capacity needs for those cases. A value of 2,300 PCE per hour per lane was used as the Level of Service (LOS) E capacity. A 10% peaking factor was applied to the average peak hour volumes to reflect peaks within the peak period.

Figure 5-4 illustrates and summarizes the volume-to-capacity (v/c) ratios projected for the PM peak hour traffic volumes under each scenario.

In the peak (northbound) direction, the gap closure is projected to operate at LOS F with v/c ratios exceeding 1.0 for all scenarios except Scenario 7 which is projected to operate at LOS D. More specifically, the scenarios with the Huntington Drive Interchange are projected to operate at poorer levels of service than the scenarios without the interchange.

## 5.6 Comparison of Alternative Scenarios

Figure 5-5 illustrates and summarizes the results of the comparison of gap closure traffic volumes for 3-lane and 4-lane alternatives, with and without the Huntington Drive Interchange. Each alternative is further analyzed with and without trucks.

Scenarios 2 and 6 were compared to understand the effect of adding a lane in each direction for the “with Huntington Drive Interchange” alternatives. While the 4-lane Scenario would attract approximately 1,000 PCE more than the 3-lane Scenario during the PM peak hour, there would be an overall improvement in level of service through the tunnel with the 4-lane configuration.



Figure 5-2 2030 Route 710 Tunnel AM Peak Hour Traffic (in PCE)

2030 ROUTE 710 TUNNEL AM PEAK HOUR TRAFFIC (in PCE)

	Northbound		Southbound	
	S/o HDI	N/o HDI	S/o HDI	N/o HDI
Scenario 2	6,590	5,010	8,360	6,610
Scenario 3	6,010	6,010	7,800	7,800
Scenario 4	6,160	4,680	7,980	6,270
Scenario 5	4,760	4,760	6,410	6,410
Scenario 6	7,090	5,240	9,060	6,960
Scenario 7	5,300	5,300	7,330	7,330

HDI = Huntington Drive Interchange

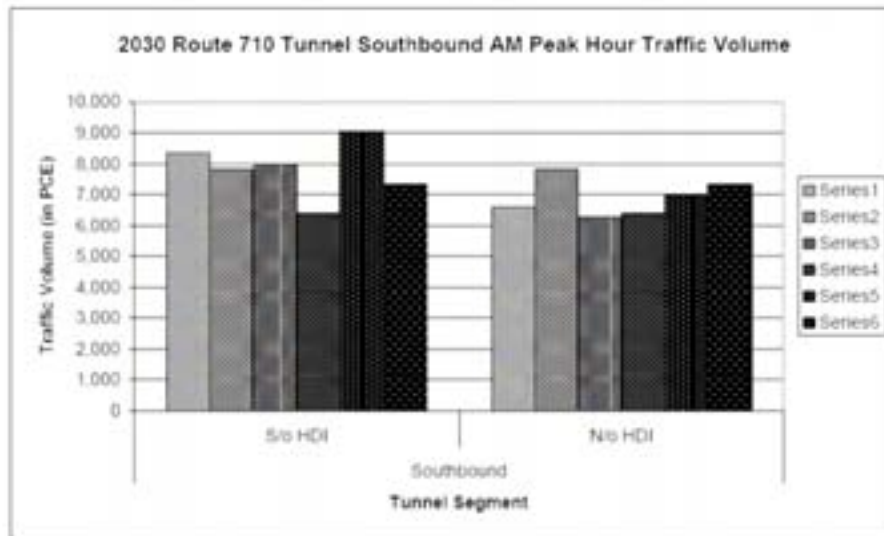
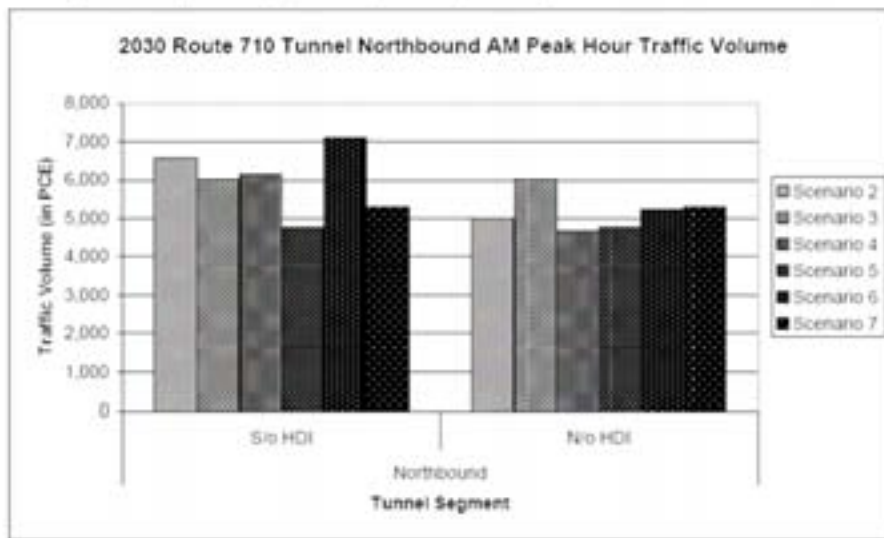

Figure 5-3 2030 Route 710 Tunnel PM Peak Hour Traffic (in PCE)

2030 ROUTE 710 TUNNEL PM PEAK HOUR TRAFFIC (in PCE)

	Northbound		Southbound	
	S/o HDI	N/o HDI	S/o HDI	N/o HDI
Scenario 2	8,780	6,200	6,500	5,390
Scenario 3	6,520	6,520	5,520	5,520
Scenario 4	8,400	5,870	6,240	5,210
Scenario 5	6,390	6,390	5,190	5,190
Scenario 6	9,750	6,650	7,060	5,700
Scenario 7	7,410	7,410	5,810	5,810

HDI = Huntington Drive Interchange

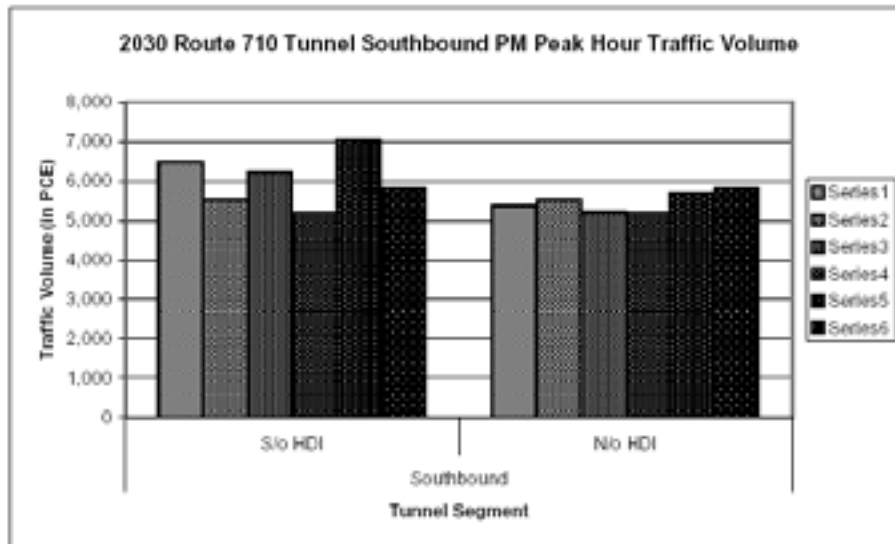
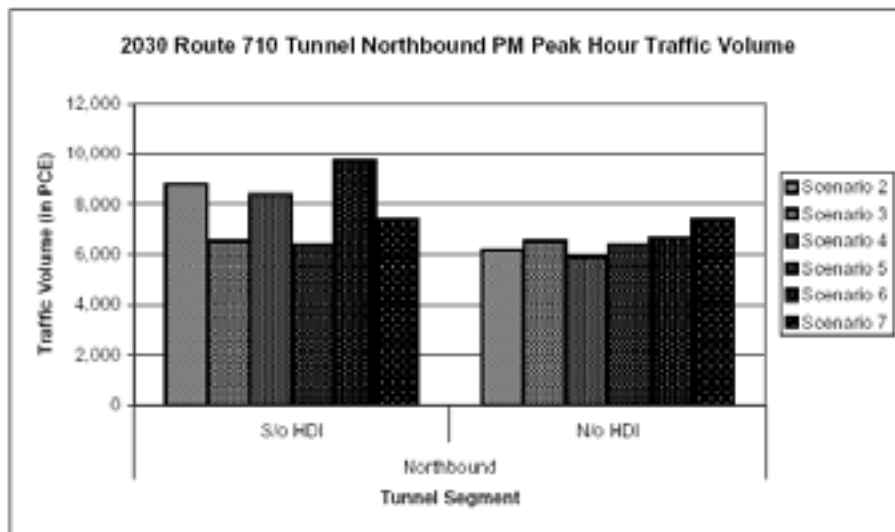

Figure 5-4 Route 710 Tunnel Configuration Scenarios

		PM Peak Hour					
		Northbound Volume					
		Scen-2	Scen-3	Scen-4	Scen-5	Scen-6	Scen-7
N/o HDI	PCE/In	2,275	2,391	2,153	2,342	1,828	2,037
S/o HDI	PCE/In	3,219	2,391	3,080	2,342	2,681	2,037

		PM Peak Hour					
		Northbound V/c Ratio					
		Scen-2	Scen-3	Scen-4	Scen-5	Scen-6	Scen-7
N/o HDI	V/c	0.99	1.04	0.94	1.02	0.79	0.89
S/o HDI	V/c	1.40	1.04	1.34	1.02	1.17	0.89

		PM Peak Hour					
		Southbound Volume					
		Scen-2	Scen-3	Scen-4	Scen-5	Scen-6	Scen-7
N/o HDI	PCE/In	1,976	2,025	1,910	1,901	1,569	1,599
S/o HDI	PCE/In	2,384	2,025	2,287	1,901	1,942	1,599

		PM Peak Hour					
		Southbound V/c Ratio					
		Scen-2	Scen-3	Scen-4	Scen-5	Scen-6	Scen-7
N/o HDI	V/c	0.86	0.88	0.83	0.83	0.68	0.70
S/o HDI	V/c	1.04	0.88	0.99	0.83	0.84	0.70

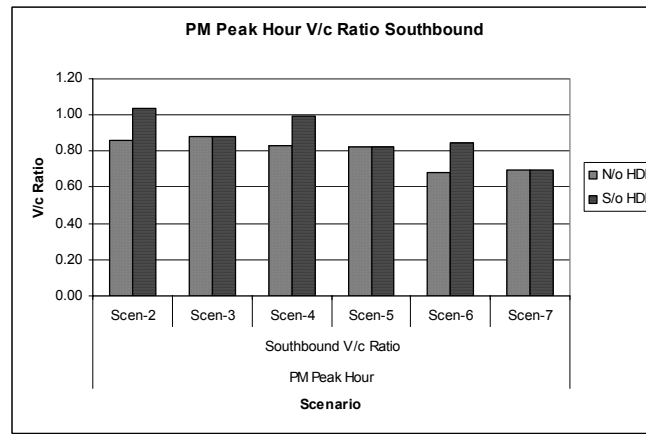
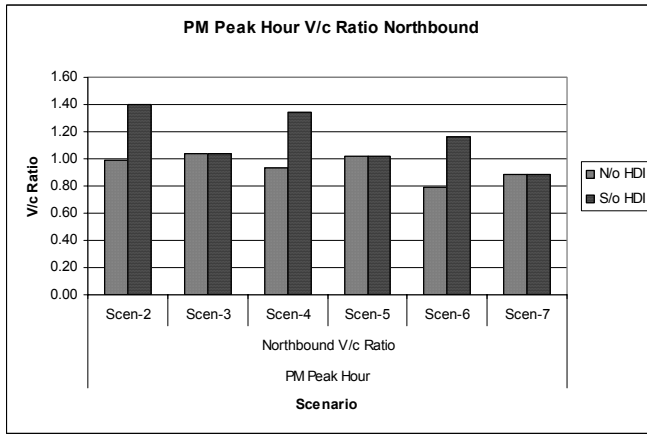

		PM Peak Hour					
		Northbound					
		Scen-2	Scen-3	Scen-4	Scen-5	Scen-6	Scen-7
		3	3	3	3	4	4
N/o HDI	Auto	4,739	4,987	5,871	6,386	5,212	5,781
	Truck	586	614	0	0	574	650
	PCE	6,204	6,522	5,871	6,386	6,647	7,406
S/o HDI	Auto	7,121	4,987	8,400	6,386	8,095	5,781
	Truck	663	614	0	0	662	650
	PCE	8,779	6,522	8,400	6,386	9,750	7,406

		PM Peak Hour					
		Southbound					
		Scen-2	Scen-3	Scen-4	Scen-5	Scen-6	Scen-7
		3	3	3	3	4	4
N/o HDI	Auto	4,147	4,029	5,209	5,185	4,396	4,312
	Truck	497	597	0	0	523	601
	PCE	5,390	5,522	5,209	5,185	5,704	5,815
S/o HDI	Auto	5,160	4,029	6,238	5,185	5,639	4,312
	Truck	537	597	0	0	569	601
	PCE	6,503	5,522	6,238	5,185	7,062	5,815

Figure 5-5 Comparison of Scenarios

	Scenario 2		Scenario 6	
	NB	SB	NB	SB
N/o HDI	6,204	5,390	6,647	5,704
S/o HDI	8,779	6,503	9,750	7,062

	Northbound		Southbound	
	Scen-3	Scen-7	Scen-3	Scen-7
Volume	6,522	7,406	5,522	5,815

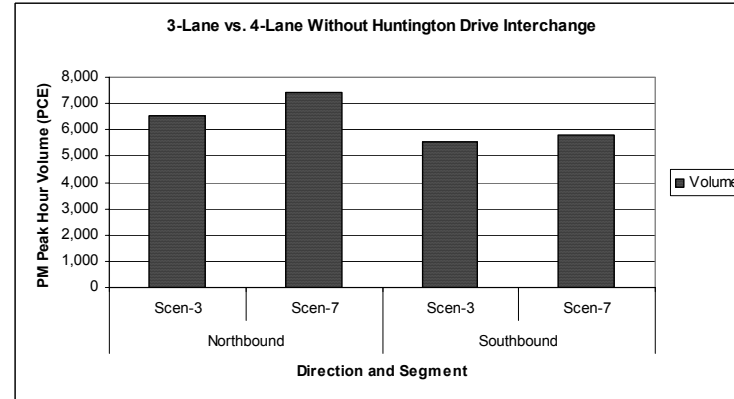
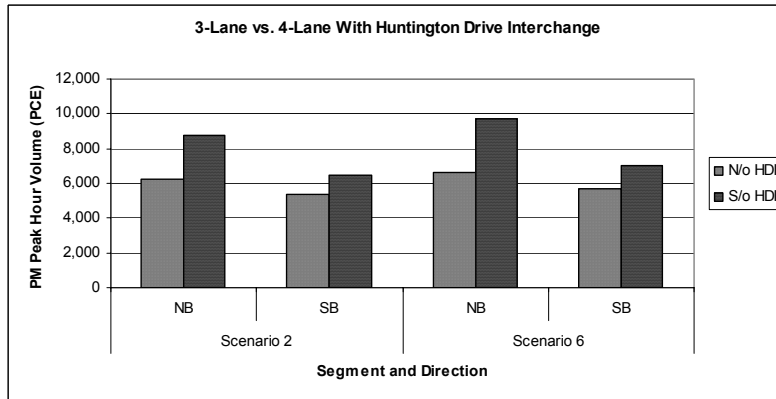

	Northbound		Southbound	
	Scen 2	Scen 4	Scen 2	Scen 4
N/o HDI	6,204	5,871	5,390	5,209
S/o HDI	8,779	8,400	6,503	6,238

	Northbound		Southbound	
	Scen-3	Scen-5	Scen-3	Scen-5
Volume	6,522	6,386	5,522	5,185

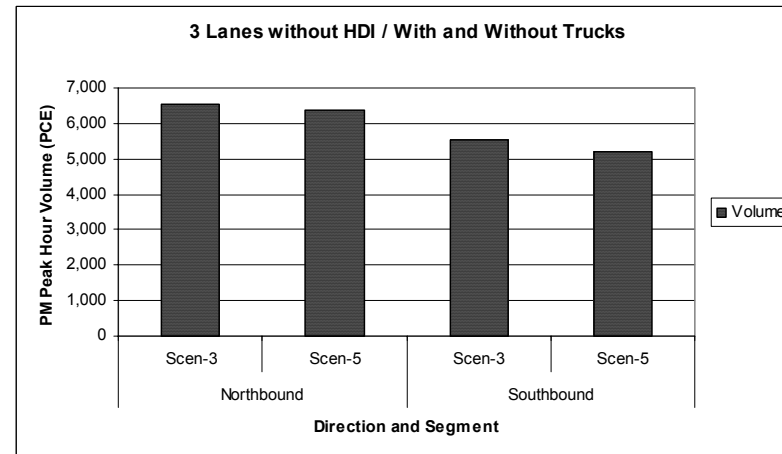
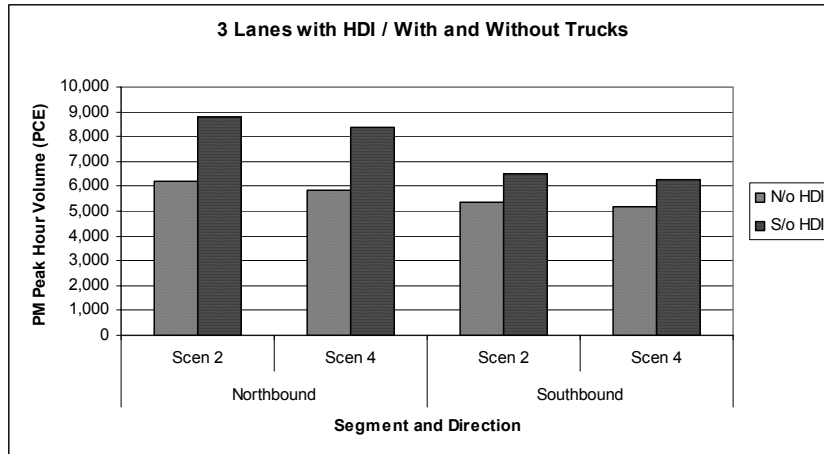

Scenarios 2 and 4 were compared to understand the effect of excluding truck-traffic from the tunnel for the “with Huntington Drive Interchange”. A reduction of approximately 600 PCE is projected during the PM peak hour, in the scenario with autos only.

Scenarios 3 and 7 were compared to understand the effect of adding a lane in each direction for the “without Huntington Drive Interchange” alternatives. The 4-lane Scenario 7 is projected to carry approximately 900 PCE per hour more than the 3-lane Scenario 3. Scenarios 7 and 3 are projected to operate with v/c ratios of 0.89 and 1.04 respectively.

Scenarios 3 and 5 were compared to understand the effect of excluding truck-traffic from alternatives “without the Huntington Drive Interchange”. The auto-only Scenario 5 is projected to operate at v/c ratio of 1.02, and carry 900 PCE per hour less than Scenario 3 which includes truck-traffic.

## **5.7 Changes in Freeway and Arterial Street Traffic Volumes**

Traffic from freeways and arterial streets is expected to be diverted to the gap-closure. Changes in freeway and arterial street traffic volumes were analyzed for specific scenarios relative to the 2030 Base Condition without the gap-closure. General traffic pattern shifts / changes were observed from the regional travel demand forecasting model results.

### **5.7.1 Freeway Traffic Volume Changes**

Scenarios 2 and 6 were compared with the Base Condition to observe the changes in traffic volumes on Freeways for the 3-lane and 4-lane alternatives with the Huntington Drive Interchange. Figure 5-6 illustrates and summarizes the changes in freeway traffic volumes for Scenarios 2 and 6 relative to the 2030 Base Condition.

It is seen that traffic volumes at all freeway segments analyzed, except two, would decrease with the tunnel alternatives relative to the Year 2030 Base Condition. Traffic volumes on freeway segments at the two ends of the tunnel are projected to increase. On Route 710 at the southern end of the gap closure the increase would be approximately 2,000 PCE per hour, and on Interstate 210 West / North at the northern end of the tunnel the increase would be approximately 2,500 PCE per hour in the peak direction. The latter represents an increase in traffic volume of 7% over the Year 2030 Base Condition estimates.

### **5.7.2 Arterial Street Traffic Volume Changes**

Traffic volumes on arterial streets for the 4-lane Scenarios 6 and 7 were compared with the Year 2030 Base Condition traffic volumes to observe traffic volume changes as a result of the gap-closure alternatives.

Figure 5-6 Freeway Traffic Pattern Changes from 2030 Base

	NB / EB		SB / WB	
	Scen-2	Scen-6	Scen-2	Scen-6
I-5 s/o US 134	-622	38	66	189
SR 110 s/o Orange Grove	-273	-247	-77	-70
SR 2 n/o US 134	-590	-490	-677	-683
SR 2 s/o US 134	-560	-465	-749	-739
I-605 n/o I-105	-90	-11	-65	110
I-210 at Allen Av	-66	-550	-754	-264
I-210 n/o US 134	2,540	2,504	1,901	2,036
I-710 s/o I-10	1,931	1,978	640	680
I-10 at Herbert Avenue	-466	-261	121	106
I-10 e/o Atlantic Boulevard	-486	-455	-633	-631

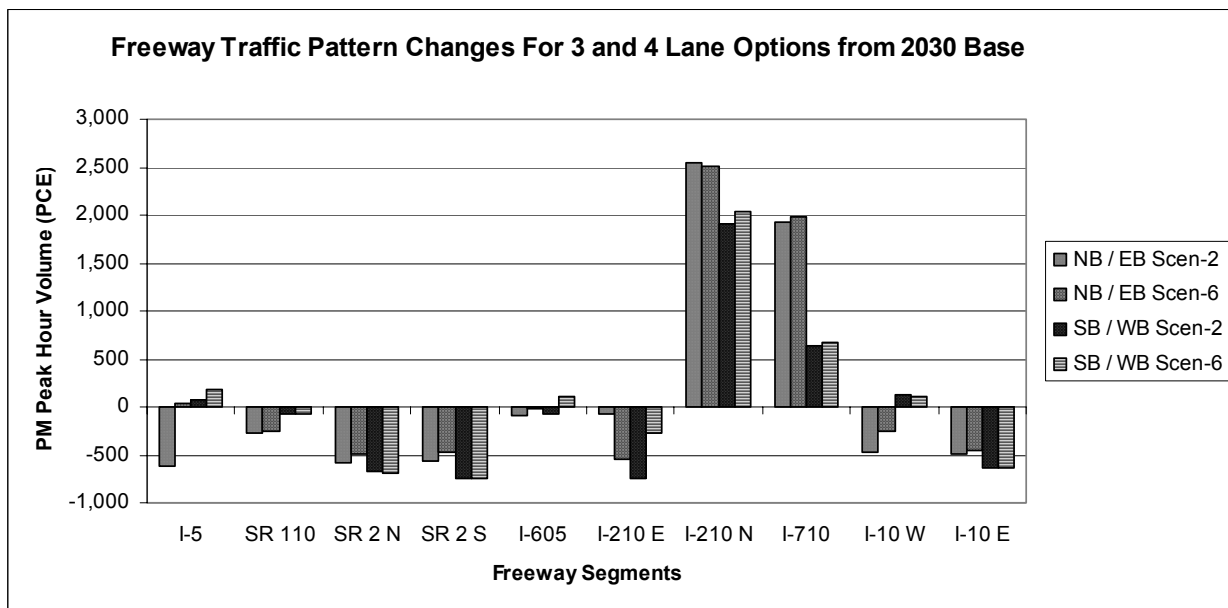

Figure 5-7 illustrates the Year 2030 Base AM and PM peak hour traffic volumes on several arterial street segments in the vicinity of the tunnel. Traffic volumes vary from approximately 2,500 to 3,000 PCE in the peak direction during the PM peak hour on Fremont Avenue immediately north of Valley Boulevard, to approximately 1,000 to 1,200 PCE per hour on Atlantic Boulevard and Garfield Avenue.

Figure 5-8 illustrates the changes in traffic volumes on arterial street segments for Scenarios 6 and 7 relative to the Year 2030 Base Condition. These scenarios were selected for comparison, since the former incorporates the Huntington Drive Interchange, and the latter does not. The following groups of streets are represented by the three charts in the illustration:

- Street segments that are in the immediate vicinity of the southern end of the proposed tunnel (includes Los Robles Avenue and Oak Knoll Avenue from Group 3 below)
- Huntington Drive segments
- Street segments north of Huntington Drive

It is seen that traffic volumes for both gap-closure scenarios generally decrease on all arterial streets segments at the southern end of the tunnel, including the Route 710 on-and off-ramps at Valley Boulevard, Valley Boulevard itself, Fremont Avenue, Atlantic Boulevard and Garfield Boulevard. The decrease is greater for Scenario 6 which includes the Huntington Drive Interchange, than for Scenario 7 which does not. This is to be expected, since the Huntington Drive Interchange would provide an additional opportunity for vehicles to exit and enter the proposed tunnel.

Relative to the Base Condition, traffic volumes increase on Huntington Drive west of Fremont Avenue for Scenario 6 which includes the Huntington Drive Interchange. Traffic volumes on Huntington Drive decrease for Scenario 7 relative to the Base Condition. This pattern reflects longer trips using the tunnel in the Scenario without the Huntington Drive Interchange.

Generally, traffic volumes on arterial street segments north of Huntington Drive are projected to decrease with the gap-closure alternatives. In particular, significant reductions in projected traffic volumes are observed at Pasadena Avenue and St. John Avenue at California Boulevard. Reductions in traffic volumes are also observed on Fair Oaks Avenue and California Boulevard.

### **5.7.3 Arterial Streets Volume-to-Capacity Ratios**

Figure 5-9 illustrates the PM Peak Hour volume-to-capacity ratios on arterial street segments for the Year 2030 Base Condition and Gap-Closure Scenario 7. This scenario does not include the Huntington Drive Interchange, and consequently all street segments are projected to operate at better levels of service relative to the Base Condition. The arterial street volume-to-capacity ratios were calculated using a capacity of 900 PCE / hour / lane.

Figure 5-7 2030 BASE AM and PM Peak Hour Arterial Streets Traffic Volumes

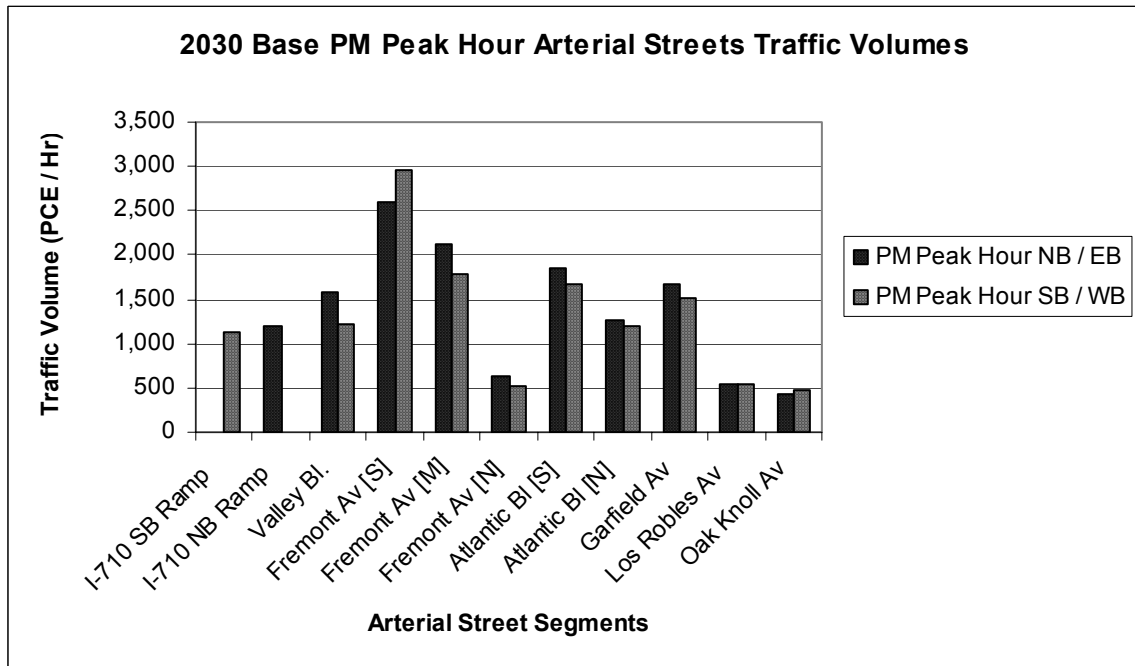
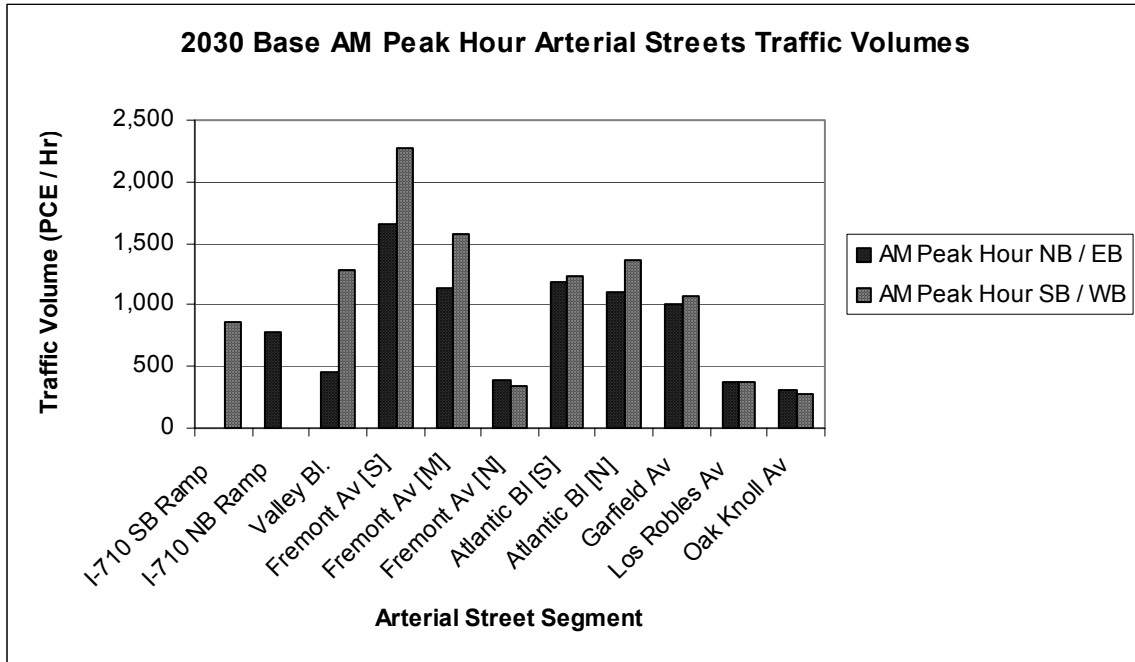

I-710 SB Ramps at Valley Bl	Fremont Av [M] n/o C'wealth	Garfield Av n/o Huntington Dr
I-710 NB Ramps at Valley Bl	Fremont Av [N] n/o Huntington	Los Robles Av n/o Huntington
Valley Bl v/o Fremont Av	Atlantic Bl [S] n/o Valley Bl	Oak Knoll Av n/o Huntington
Fremont Av [S] n/o Valley Bl	Atlantic Bl [N] n/o Main St	



Figure 5-8 2030 Traffic Pattern Changes – Scenario 6 and 7 vs. Base Arterials Streets

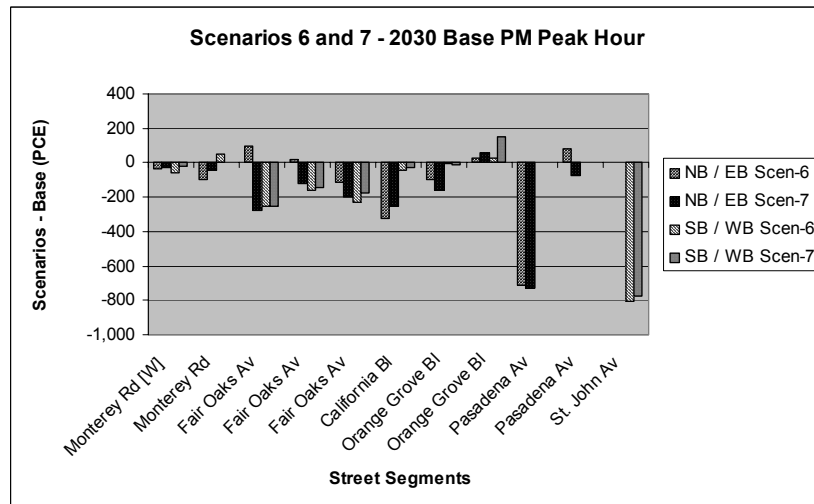
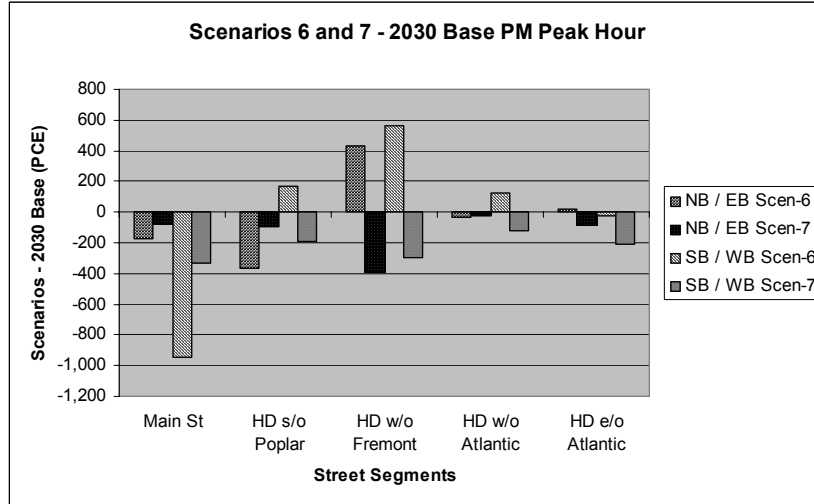
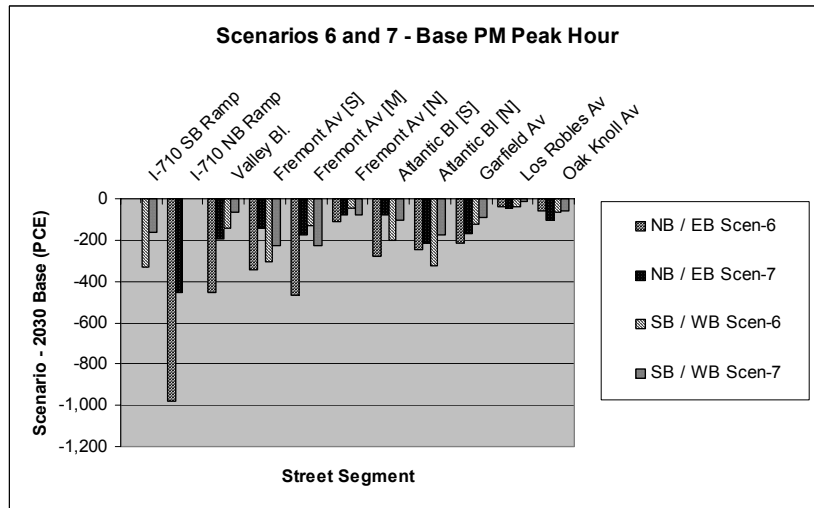
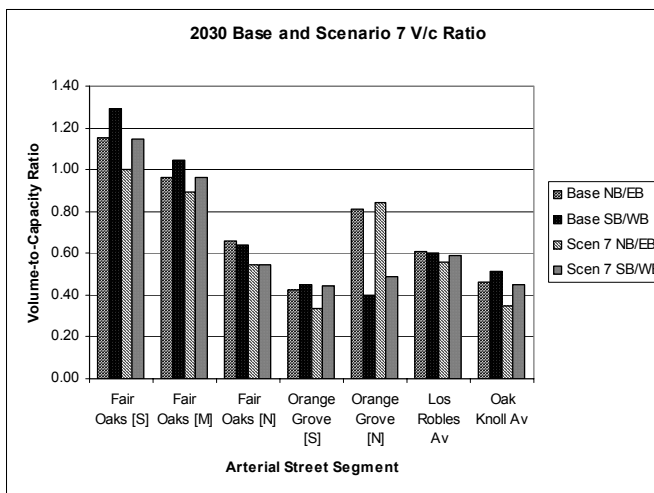
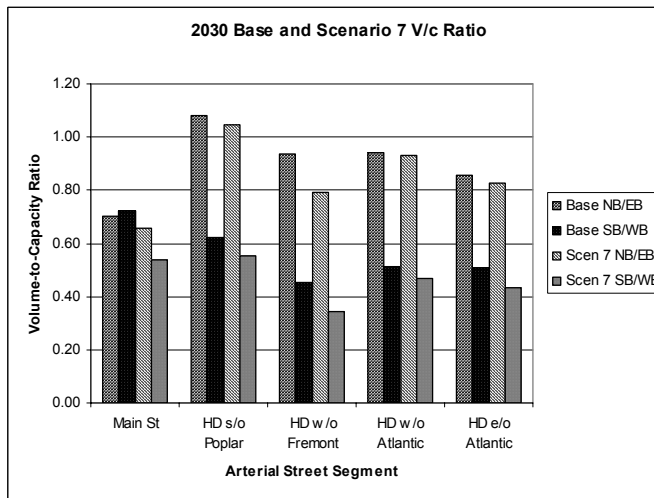
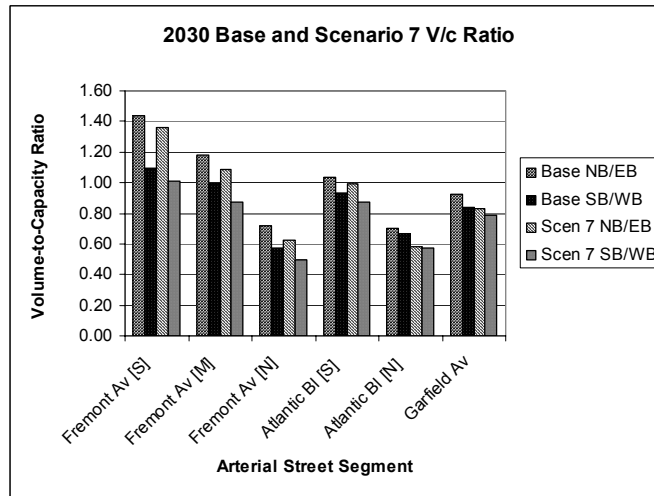

Figure 5-9 2030 Volume to Capacity Ratios



## 5.8 Traffic Analysis Conclusions

This traffic analysis is intended to provide rough order of magnitude (ROM) estimates and preliminary guidance regarding the adequacy of the number of lanes to accommodate anticipated tunnel traffic volumes. An overview of changes in traffic patterns expected on freeway segments and arterial streets associated with the proposed tunnel alternatives is presented. The traffic analysis performed at this conceptual stage is not intended to be a detailed travel demand forecasting exercise, or a traffic / transportation impact analysis typically performed during the environmental phase of projects.

The major findings of the analysis are presented below:

- The capacity of the 3-lane / direction gap-closure alternatives would not be adequate to accommodate projected 2030 traffic volumes.
- The 3-lane alternatives without the Huntington Drive Interchange performed better than those with the interchange.
- The 3-lane alternatives that excluded truck-traffic performed better than those that included truck-traffic.
- The 4-lane alternatives performed better than comparable 3-lane alternatives.
- Among the 4-lane alternatives, the Scenario without the Huntington Drive Interchange performed better relative to that with the interchange.
- Except for freeway segments at the two ends of the proposed tunnel, where traffic volumes are projected to increase relative to the 2030 Base Condition, traffic volumes generally decreased on freeway segments as a result of the gap-closure.
- Traffic volumes generally decrease on arterial streets in its vicinity as a result of the gap-closure.
- The southerly segment of the gap-closure scenario with the Huntington Drive Interchange is projected to accommodate significantly higher traffic volumes than the northerly segment.
- Traffic exiting at the Huntington Drive Interchange would generate the need to significantly increase arterial street capacity.

Based on the findings described above, the 4-lanes per direction alternative without the Huntington Drive Interchange is projected to perform best relative to all other alternatives analyzed.

This Page Intentionally Left Blank

## 6.0 Tunnel Configuration and Alignment

### 6.1 Introduction

The study has addressed the physical feasibility of engineering a tunnel solution to complete the gap in the Southern California regional highway network along the Route 710 corridor. At grade and shallow tunnel solutions have been considered in the past and were found to be problematic as issues arose regarding the land requirements, noise and other environmental and community concerns that would result from an at-grade solution.

It would appear that a tunnel might offer a solution by channeling the Route 710 traffic below the surface streets and communities; the Route 710 tunnel feasibility study has addressed the main issues relating to the viability of an underground solution by examining the engineering, traffic, environmental and financial aspects of a tunnel option. **The study examined issues that would affect the feasibility of the tunnel solution and identified major issues that would be involved in developing the project any further. It has not investigated or selected alignments and solutions nor has it assessed the level of impacts that would result from completion and operation of a tunnel project. These issues would need to be addressed as part of a subsequent extensive process for Route Selection, Preliminary Engineering, Environmental Assessment, and Community Involvement process.**

### 6.2 Engineering Considerations

A number of engineering factors must be considered in selecting the tunnel alignment and configuration to be assumed to establish tunnel feasibility and viability. This chapter addresses the physical size and alignment requirements considered in the optional tunnel configurations. There are other issues regarding environmental, community and land use issues that could also influence the alignment and these are discussed in other chapters of this report.

#### 6.2.1 Geotechnical

The study tasks covered in Chapter 3 focused on the subsurface ground conditions based upon available geological data and supplemented with a minor geotechnical exploration program consisting of drilling three deep exploratory boreholes along the study corridor.

The study area for the potential tunnel alignments is quite large being over 4 miles long and 2 miles wide, and with the tunnel likely to be as deep as 300 feet below the surface. The necessary subsurface data to enable full design would require much more extensive subsurface exploration program to augment the geotechnical information that is available at this time.

The currently available geotechnical information indicate that tunneling conditions are favorable with predominantly soft sedimentary rock and reasonable water conditions that could be overcome using general tunnel construction methods. There are fault zones and potential for seismic activity along the corridor. However it is not an unusual condition for transportation

tunnels in the Los Angeles basin and there are strategies to address this situation during the design and construction.

### **6.2.2 Traffic**

Traffic modeling has been performed to evaluate the regional network and general impacts on local arterial roads due to the closing the Route 710 gap. This is reported in Chapter 5 entitled Travel Modeling and Forecasts.

The modeling analysis has been based upon alternative tunnel concepts with consideration of options with 3 or 4 lanes provided in each direction; as well as options with and without truck traffic through the tunnel. The option of including a new interchange with the east-west arterial at Huntington Drive has also been examined and it has been found that this proposal would increase traffic demand along the Route 710 tunnel lanes, as well as on Huntington Drive, as a result of additional trips accessing Route 710 via this route. This would also indicate that additional lanes along portions of Huntington Drive would be required, to cope with this additional traffic.

The general conclusions reached are that there would be a demand for 4 traffic lanes in each direction to meet year 2030 projected traffic conditions and that this facility could accommodate truck traffic along the corridor.

### **6.2.3 Tunnel Construction Technology**

Chapter 2 has discussed Tunneling Technologies and examined similar completed tunnel projects worldwide, along with currently available tunnel engineering methods and technologies that might be applicable to the Route 710 tunnel concepts.

This document concluded that two tunneling construction methods are appropriate for further consideration for the Route 710 tunnel. These methods include Tunnel Boring Machines (TBM) and Sequential Excavation Method (SEM). TBMs are currently in operation for tunnels up to 50 feet in diameter. SEM is suitable for 4-lane tunnel cross-sections. Cut-and-cover methods for tunneling have been discounted, as they would involve significant disruption at the surface both during construction and in the future when the large areas of land on top of the tunnels were to be redeveloped.

## **6.3 Tunnel Configuration**

The study has considered a number of tunnel and cross-section arrangements to meet the indicated requirement for 4-lanes capacity in each direction to provide an acceptable level of service through the tunnel. Various tunnel cross-sections have been evaluated and considered to achieve this level of performance. The alternatives are summarized in the nine cross-section options illustrated in Figure 6.1.

A large number of cross-sections were considered during the study, all aimed at maximizing the usable space within the cross section to allow passage of trucks and all other traffic, while

maintaining roadway standards. The cross sections would also need to accommodate spaces for ventilation, signage, walkways, access to cross passages, and all other facilities required for tunnel systems such as lighting, fire equipment and various control, detection and surveillance. These would need to be considered in more detail at future stages of development.

The nine sections considered in this report are preliminary and could all be further examined to reconfigure lanes and clearances to meet particular traffic needs, whilst maximizing usable space.

Accommodating four lanes requires a large tunnel cross-section, larger than any yet constructed in the United States by mining methods for a long tunnel, other than shallow cut-and-cover construction. The tunnel would therefore require state-of-the-art tunneling techniques and equipments.

Figure 6-1 Cross Section Matrix

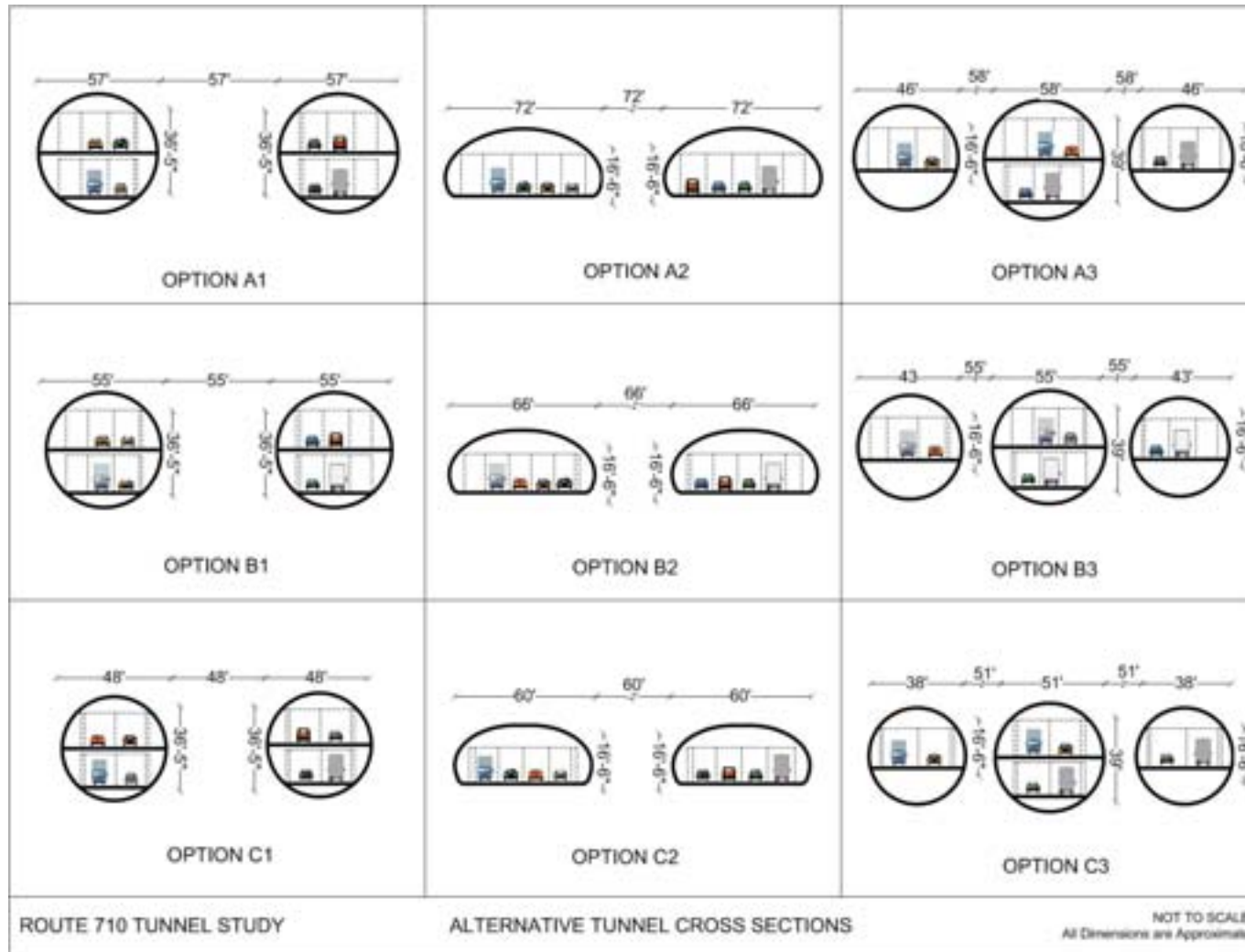



### 6.3.1 Cross-section A1

Cross-section option A1 considers two Tunnel Boring Machine (TBM)-driven tunnels, each about 57 feet in diameter, which is larger than the largest tunneling machine constructed to date of approximately 50 feet in diameter. From discussions with TBM manufacturers, it is anticipated that larger diameters (60 feet) will become possible within the industry over the next decade. This tunnel option requires a double deck configuration of lanes with each level having two full standard 12-foot wide traffic lanes, a continuous 10-foot wide shoulder on the right side, and a two-foot wide inside shoulder. This configuration provides four mixed traffic lanes in one direction and a total of eight traffic lanes for the two tunnels. Full vertical clearance of 16' 6" is provided at each level. In addition, the lower deck level has been assumed to have an additional 3' 6" above lanes, to allow for location of signage and other tunnel systems equipment. On the upper deck, space for signage can be provided above the lanes attached to the curved ceiling at that level. The upper roadway slabs have an assumed thickness of 2' 6".

This option also provides space at each side for walkways to be used by maintenance staff and drivers if there is an incident in the tunnel. National Fire Protection Association's (NFPA), the governing national organization, regulations require cross-passage connections to allow escape of tunnel users to a place of safe refuge, in this case the opposite parallel tunnel. At this stage, these cross-passages are proposed at 600-foot intervals along the alignment for this tunnel configuration. They would be provided at each deck level connecting to the corresponding deck level in the opposite tunnel.

### 6.3.2 Cross-section A2

This cross-section option indicates two mined tunnels, constructed using the Sequential Excavation Method (SEM), each with a 72 foot width providing four full standard 12-foot wide traffic lanes, a continuous 10-foot wide right side shoulder, and a two-foot wide inside shoulder on a single level. Side walkways would again be provided with cross passages to the opposite tunnel. Spacing of these cross passages is proposed at 500 feet spacing along the alignment, closer than that for option A1, to reflect the need to evacuate larger numbers of persons using four 4 lanes of traffic on a single level to the safe refuge.

Vertical clearance of at least 16'6" is provided with adequate additional space for signage and other equipment above the lanes.

Additional detailed geotechnical and structural engineering will be needed to determine whether the subsurface soil conditions along the gap corridor is well suited for this cross-section.

### 6.3.3 Cross-section A3

This cross-section option provides eight lanes of traffic using a three tunnel configuration with outer tunnels each providing two lanes in one direction and a double deck center tunnel with two lanes on each level, with one deck serving each direction.

The center tunnel was assumed to be around 58 feet in diameter again just above the current state of the art for TBM constructed tunnels but likely feasible in the timeframe of this project development. The outer tunnels, also assumed to be TBM driven have a diameter of approximately 47 feet. Modifications to these 3 tunnel configurations and sections could be examined further as part of any future project development.

The traffic lanes would all be 12-foot wide with 10-foot wide right shoulders and two-foot wide inside shoulders; and with space for walkways, 16'6" vertical clearance, and space above the lanes for signage and other systems equipment.

In this case, pedestrian cross passages would be needed from both decks of the center tunnel to the outer tunnels at 600 feet spacing along the alignment.

#### **6.3.4 Cross-sections B1, B2, and B3**

Cross-section options B1, B2, and B3 have the same general configuration as the full-standard options A1, A2, and A3 respectively, but with the incorporation of reduced design standards in these cross-section options.

From the study of worldwide and domestic tunnels (see Chapter 2), it is typical practice for lengthy tunnels to implement features that comply with full standards and other features with "reduced" standards as an economic measure. However these design decisions must be made carefully to maintain the integrity of the design such that public safety is not compromised. The adoption of "reduced" standard design features must be weighed carefully to balance public safety against capital investment. For the Route 710 tunnel alternatives, the roadway geometrics provide long tangent section and large radii curves, which yield very favorable conditions for the motorists with generous sight distances. Due to these favorable geometric conditions, it is reasonable to give consideration to some reduced standard roadway features for these tunnel cross-sections.

In the cases of cross-sections B1, B2 and B3, initial informal discussions with Caltrans has indicated that they would consider the use of traffic lanes with reduced width as can be seen on many urban freeways. In the light of these discussions, a set of options with 11-foot wide lanes and a single 12-foot wide 'truck' lane maintained in each direction, has been used to modify options A1, A2, and A3. Also the right-side shoulders have been reduced from 10 feet wide to 8 feet wide. These cross-section options maintain the inside shoulder width of 2 feet. Vertical clearances, walkway and cross-passage provisions remain as before.

The standard reduction results in reduced tunnel dimensions that may reflect significant reductions in mined volumes and may realize valuable cost advantages.

#### **6.3.5 Cross-sections C1, C2, and C3**

Cross-section options C1, C2, and C3 adopt further reduction in cross-section standards to reflect those found in modern major highway tunnels in other parts of the world. Standards remain the same as those used in options B1, B2 and B3, but with the right side margin reduced

further, from 8 feet to 2 feet. Vertical clearances, and walkway and cross-passage provisions remain as before.

These standards have been used successfully in other long, high volume highway tunnels, when used in conjunction with close monitoring and control of traffic using systems such as CCTV and variable message signs to deal with incidents and changed traffic conditions within the tunnel environment.

## **6.4 Alignment**

Many factors will need to be considered in any subsequent determination and selection of a tunnel alignment. Obviously the traffic demand will have to be met, as well as air quality concerns. The tunnel would have to be constructed to minimize impacts on the local area in terms of noise, visual, severance of local streets, community and neighborhood and to avoid impacts on the historic districts and buildings that are of both local and national value.

The alignment must be selected to avoid potentially impacting particularly sensitive land uses such as schools, hospitals, etc.

The alignment design will need to meet safety requirements in terms of highway alignment standards to allow for safe traffic operations and permit emergency access and egress in the event of any incidents within the tunnel.

### **6.4.1 Three Typical Alignments**

For the purpose of this initial study, specific alternatives have not been assessed for selection of a preferred alignment. A wide study corridor with three typical alignments was considered so that feasibility could be established, and approximate costs and potential issues that might require mitigation could be identified.

The “No-Build” option needs to be considered in the decision to proceed with this project. Without the ‘710 Gap’ completion, there would be further increases in local traffic in the Pasadena, South Pasadena, El Sereno (Los Angeles), Alhambra and San Marino areas, with further extensions to the peak traffic periods and increasing subsequent deterioration in noise levels, vibration, air quality, and pedestrian and traffic safety. This would also lead to new provisions to widen the main arterials, increase the capacity of intersections, and introduce further traffic control and management measures to channel traffic and attempt to avoid impacts to the largely residential neighborhoods of the corridor. Regionally, it would perpetuate congestion on the already overloaded local freeway network such as the I-5, SR-2, SR-134 and I-210 corridors, with resultant capacity and widening issues, further air quality deterioration and noise issues impacting journey times and the surrounding communities beyond the study corridor.

Three representative tunnel alignments were evaluated to identify the range of costs, ability to accommodate a potential interchange along Huntington Drive and ventilation buildings, and

other issues relevant to the feasibility of a tunnel solution. Figure 2 provides an illustration of the three generalized alignments that were considered.

*Alignment A* would follow a corridor approximately along the previously proposed Meridian at-grade alignment, with the advantage of passing under property previously acquired by Caltrans for highway development. It also gives a fairly direct route, thereby shortening the tunnel, which would become just over 4 miles in length (21,160 feet).

The alignment assumes gentle horizontal curves of over 10,000 feet radius to allow good visibility and speed standards; vertical grades from 1.95 % to 3% at the steepest rise up to the north portal are also assumed. The tunnel would pass mainly under residential land uses.

*Alignment B* would follow a slightly longer alignment at 4.05 miles (21,390 feet) and would pass around the existing Fremont Avenue corridor and would require horizontal radii of between approximately 8,000 and 20,000 feet, with a similar profile grade range. The grades employed would range between 1.20% and 2.89%. This alignment would pass under mainly residential and some commercial land uses.

*Alignment C* would be further east, passing along the Huntington Drive and Fair Oaks Avenue corridor with a length of 4.12 miles (21,740 feet). The grades employed would range between 1.30% and 3.55%. This tunnel would pass under a mix of residential and commercial land uses.

Alternative horizontal tunnel alignments within the study corridor are representative of the likely range of alignments that may be subsequently evaluated. These initial example alignments assumed uniform geological conditions based on the information reported in Chapter 3.

The ends of the alignment are defined laterally by the locations of the termination of the I-710 freeway at Valley Boulevard in the south and the resumption of the I-710 freeway at Del Mar Boulevard in the north. Most of the intervening land along the representative alignments is residential or commercial properties, which have proved to be unsuitable for at-grade solutions in the past and therefore the possible tunnel solution has been assumed to extend for much of the gap.

Figure 6-2 Alignment Map



### 6.4.2 Portal Locations

Locations for the portals could not be selected as part of this initial study but assumptions were made in order to assess potential impacts and identify approximate costs. In later stages of a tunnel project extensive investigation of site conditions would be required to determine the portal locations. These would include geotechnical, environmental, and traffic considerations relating to the approaches, local road layout, and sites of ventilation and other tunnel related structures.

#### *Southern Portal*

The southern portal location has been assumed in the same place for all three representative alignments in an industrial area just north of Mission Road. Much of this land was previously acquired by Caltrans and it provides a suitable site for location of the deep tunnel portal excavation. From the termination of the current I-710 pavement, the profile of the new highway would continue downward to pass under Valley Boulevard, the double-tracks of the Union Pacific Railroad and Mission Road to the point where the southern portal would be located south of Concord Avenue. This would require construction of new bridges to carry Valley Boulevard, the railroad, and Mission Road over the extension of Route 710 at the southern approach to the tunnel. A new bridge would also allow for the realignment of Mission Road where it currently has a sharp reverse curve alignment bending at the boundary between the Cities of Alhambra and Los Angeles.

It is assumed that the portal construction would involve a large excavation approximately 90 feet deep to allow for 50-foot diameter tunnels for cross-section options A1 and A3, and around 70-foot diameter tunnels for cross-section option A2. It is envisioned that an extensive landscape berm and planting would be necessary to provide good screening of the visual impacts from this element of the tunnel during construction and operation stages. Noise barriers may also need to be incorporated into the site to counter adverse local noise impacts. The land required for this portal would be largely within the industrial land that has already been acquired by Caltrans and a few, if any, additional lots in the area.

#### *Northern Portal*

The northern portal is assumed to be situated at the termination of the existing portion of the Route 710 'stub' just north of California Boulevard. Again most of the land at this location has been previously acquired by Caltrans, and the depth of the portal excavation would be similar to that for the southern portal. The portal would be connected a little further north to the existing roadway at Del Mar Boulevard.

Once more, the use of landscaping and barriers would relieve many of the visual and noise impacts of the portal area from the surrounding residential and commercial areas. The land required for this portal would be largely within the open undeveloped areas and residential land that have already been acquired by Caltrans and a few, if any, additional lots in the area.

### 6.5 Profiles

In profile, the topography generally falls from the north down to the south. At this initial stage the assumption has been made that the tunnel would nominally be aligned to provide some 100

feet of cover over the top of the tunnel structure. The profile would follow the surface except at the portal approaches where steeper grades would be needed to achieve adequate cover. The preliminary tunnel profiles provide a continuous roadway grade between 1.2% and 3.55% depending on the alternative alignment. It appears from a physical perspective that an alignment can be identified that will accommodate a profile grade of 2% to 2.5%. A profile assumed at this stage is indicated in Figure 6-3.

### **6.5.1 Cross-passages and Refuges**

Cross-passages are typically constructed in long tunnels to provide access to the adjacent tunnel. National Fire Prevention Association (NFPA) 130 guidelines recommend cross-passages between parallel tunnels to allow safe refuge from smoke and haze, and to allow occupants to pass to the safety of the parallel tunnel. These cross-passages are expected to be smaller diameter tunnels, perhaps 20 ft in diameter, and driven from one main tunnel to the other.

Safety refuges may also be provided to contain emergency equipment and a safe breathing environment for relatively short periods of time. Cross-passage and refuge spacing and functions would be subject to final design criteria developed during final design.

### **6.5.2 Shafts for Access and Ventilation**

A minimum of one mid-tunnel shaft will be required for the tunnel ventilation building, which could also include emergency access. The final number, function, and locations of shafts would be the subject of a future full analysis of ventilation requirements, but initial analysis indicates that a single mid-point ventilation building would be able to adequately serve this tunnel. This is explained in more detail later in this chapter. The final depth and dimensions of the shaft will be established based on the ventilation requirements for the number of traffic lanes, tunnel vertical alignment, and cross sectional area. Connecting tunnels (also called “adits”) to the shaft(s) would be designed and constructed using similar construction methods to the cross-passages. Further shafts, if necessary, may also be designed to provide multiple functions during construction as well as accessing the tunnel for emergencies and for operations and maintenance of the facility.

If the Huntington Drive interchange is adopted, then emergency evacuation to the parallel tunnel would not be possible and the ramp tunnels would require access shafts to the surface at intervals along their length.

Figure 6-3 Typical Profile

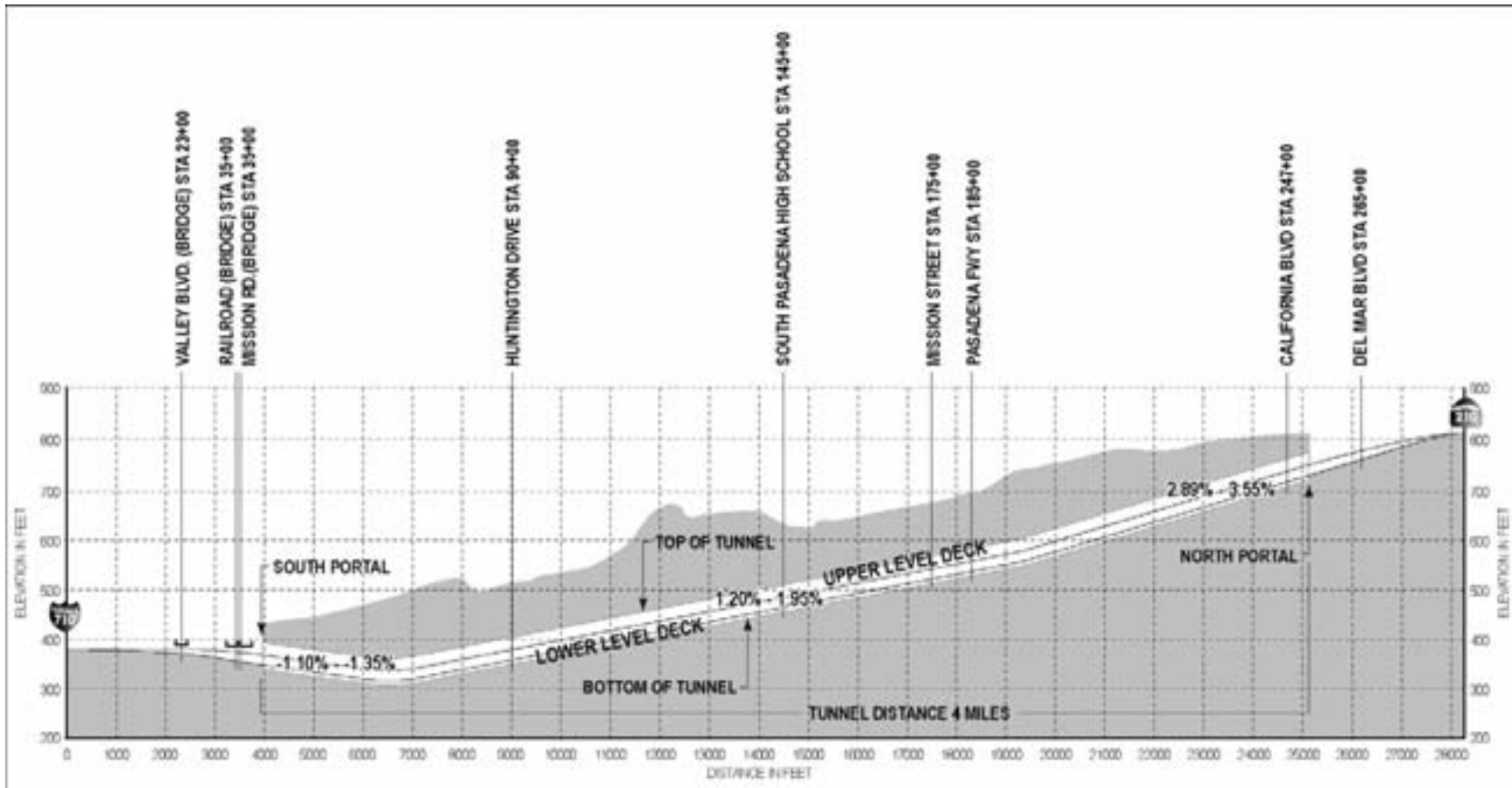



## 6.6 Tunnel Ventilation System Facilities

The initial review of tunnel ventilation requirements is included in Chapter 4 and this aspect has some influence on tunnel configuration and alignment.

Location of the ventilation buildings will require extensive investigation. Suitable sites will be required within the existing mainly residential and commercial areas somewhere near the mid-point of the tunnels. Selection of this surface site will have an important influence on the chosen alignment, as it is desirable to locate the building over or nearby the tunnel.

The ventilation buildings would be required near the Northern and Southern Portals and at one mid point location (possibly two mid-point locations) and suitable sites would need to be identified. The selected mid-point location(s) would impact the alignment although it is feasible to locate the ventilation structure reasonably offset from the main line of the tunnel with additional tunnels/shafts and at additional cost.

The two portal ventilation buildings would need to be at or immediately outside to the portal entrance and it appears that sufficient space could be available at the currently assumed sites.

The ventilation scheme involved in each case is assumed to be a longitudinal type, which introduces air flow into the tunnel at the portals and creates a longitudinal stream of air within the roadway and exhausts to the opposite portal. For these tunnel configurations it is anticipated that the longitudinal ventilation will be accomplished employing Saccardo Nozzles at the portals and one or two intermediate points along the tunnel. (See Figures 4.9 and 4.10) These nozzles are specially designed to create high velocity air flow. These chambers would then be connected to fan buildings used to house an array of fans that would control air flows under particular circumstances, varying from normal operation to air flows required in response to particular situations such as fire and smoke control in the tunnel. It is therefore desirable that the ventilation building is close to the tunnels and located above the two tunnels, if local site constraints allow.

This type of system is unlikely to require fan installation within the tunnel cross-section. This option is space efficient and lends itself well in the single-deck or double-deck tunnel cross-sections. The double-deck tunnel configuration has limited space for mechanical features as compared to single level cross-section and use of Saccardo Nozzles to longitudinally ventilate the tunnel is practical.

The fans could be housed in ventilation buildings largely located below ground with a stack above the surface to disperse exhaust air from the tunnel and with separate intakes to direct fresh air into the tunnel. Selecting the location for the stacks requires extensive investigation to determine local effects governing dispersions and other environmental and land use considerations.

## 6.7 Tunnel Approaches

A portion of the freeway outside of the tunnels would need to be re-constructed to transition Route 710 from a surface freeway into a subterranean facility. On the southern end of the gap, the Route 710 freeway would be extended northward beyond its current terminal at Valley Boulevard. The freeway profile would need to be lowered to go under Valley Boulevard, the Union Pacific Railroad tracks, Mission Road and ultimately match the grade entering the portal. On the northern end, the profile of the freeway near California Boulevard may need to be lowered as the roadway approaches the northern portal. For this approach it may be possible to avoid impacting the existing bridge at Del Mar Boulevard, but this would require more detailed examination at a future stage.

An additional feature common to each of the tunnel alternatives with the stacked roadway configuration (cross-section options A1, B1 and C1) is the need for the freeway to be split from a single at-grade level into two vertically separated levels so that two lanes of traffic enter the upper and lower levels of the stacked tunnels. In advance of the tunnel portals, the freeway will split horizontally into two two-lane roadways, then these roadways will transition vertically and horizontally until the roadways are directly above/below each other as they enter the tunnel. Upon exiting the stacked tunnel, the stacked roadways will transition back into a four-lane freeway on a single plane. These tunnel approach roads would fall outside each portal. This vertical separation would require structural ramps/underpass retaining wall structures outside of the portals.

In the case of the cross-section options A2, B2, C2, a wider single level approach may be required. All cross-section options may require retaining walls at the portal areas. In all cases, the available land would be largely adequate with the use of retaining walls.

## 6.8 Tunnel Construction Requirements

Normally, construction work areas might have some influence on alignment, but in this case the available areas in the existing right-of-way near each portal offer suitable work areas for establishing muck handling facilities for off-site disposal, and for assembling and dismantling of the tunneling equipment such as the TBMs.

Mid-point access to the tunnels has not been considered necessary at this early stage. Should this be required, a suitable surface site at the head of a shaft would likely be difficult to locate, given the largely residential nature of the local cities. However potential sites do exist within the study area and if needed they may also influence tunnel alignment. Construction activity would still be required to construct the mid-point ventilation building(s) and stack.

Disposal of tunnel spoil material has at this stage been assumed to be via the existing 710 and 210 freeways using the direct access available. The possibility of utilizing the Union Pacific railroad near the southern portal could also be investigated further, and it appears possible that additional rail sidings and loading facilities could be temporarily introduced at this location.

## 6.9 Tunnel Operational Requirements

The reduced standard tunnel options can potentially reduce costs and help tunnel viability. It is possible in the tunnel environment to adopt closer monitoring and control systems to improve safety and therefore allow some reduction in standards without loss of safety.

Other tunnel properties have successfully employed measures such as the control or prohibition of lane changes inside the tunnel, and the use of CCTV and lane monitors to enforce these measures. Control systems such as variable message signs are adaptable to a number of circumstances and used to indicate lane closures, changeable speed restrictions, and other information and these can be of great value in directing tunnel users safely. Good surveillance systems can also reduce hazards by allowing rapid response to incidents. Such systems along with firm enforcement of tunnel regulations can allow the more efficient use of space and reduction in normal external highway standards such as lane and shoulder widths.

With modern technology it is also possible to house the control and administration center either on the tunnel site or at a more remote location, depending upon available land. In this case, it is possible that operational facilities, such as traffic control, maintenance, staff facilities, and breakdown services, can all be based at the portal areas.

At this stage it is anticipated that the following safety provisions could be considered for inclusion in the project:

- The operator could monitor traffic approaching entering the tunnel to divert vehicles and trucks assessed to be carrying hazardous materials, or oversized or dangerous loads, for example. In some properties vehicle restrictions are imposed to reduce the risk of incidents or certain vehicles are segregated to be escorted through the tunnel or their use of the tunnel may be restricted to certain times.
- Lane controls could be considered to prohibit lane changes within the tunnel to reduce accident risk and the use of truck-only lanes could also be considered
- Lateral walkways would be provided on one or both sides of the traffic lanes to allow operations staff and pedestrians in emergency situations, to pass along the tunnel out of the traffic lanes. These would be raised above the roadway level and link to the cross passages.
- Tunnel Cross passages have been assumed at 600 feet intervals along the tunnel. These would allow tunnel users to evacuate one tunnel to a safe place of refuge in the adjacent parallel tunnel, in the event of an incident. This could be monitored and controlled by the operations center. It would also allow access by operator and emergency personnel to an incident. The passages would include special entry doors and ventilation systems to prevent movement of smoke along the escape paths.
- In the case of any ramp tunnels for the interchange options a shaft would be required to the surface at the same intervals along the ramp tunnels, to allow at escape route and entry to the tunnel by the operator and emergency personnel.

- Fire detection and smoke monitoring equipment could be included to assist the operator in controlling a fire within the tunnel. The ventilation systems would also be designed to control smoke in a fire situation and provide a safe path to evacuate the affected area of the tunnel.
- Tunnel sprinklers, fire deluge systems and extinguishers would be considered as appropriate to assist in control of fire and smoke within the tunnel, and these would be monitored at some central control point
- CCTV systems could also assist the operator in monitoring normal operations and extraordinary incidents
- Changeable message signs could be included to assist in the control of vehicles and lane management and also to direct users to the egress points in the event of an incident
- User assistance telephones would be included at intervals along the walkways to allow tunnel users to contact the control center. Public Address systems could also be considered if appropriate to give advice to users during incidents within the tunnel
- Niches could also be included at points along the tunnel to house emergency equipment and allow another point of refuge.
- Emergency lighting could be included to provide light in the event of a failure in the main tunnel lighting system
- Breakdown recovery vehicles would be available on a 24/7 basis to assist tunnel users as required.

### **6.10 Huntington Drive Interchange**

The possible need for an interchange would influence the alignment of the main tunnel. For the purposes of this feasibility study, we assumed the mainline tunnel profile would remain deep instead of raising the tunnel profile closer to the surface to accommodate the potential interchange. The advantage of keeping the tunnel deep is that the mainline tunnel could be constructed by TBM or SEM techniques. As previously noted, this minimizes the areas that may otherwise be subjected to construction by cut-and-cover methods which increase the degree of surface impact.

Chapter 3 discussed the inclusion of an interchange for non-truck traffic somewhere along Huntington Drive. The analysis concluded that the interchange would attract additional trips to the tunnel route and increase traffic on Huntington Drive and other local arterials, requiring additional lanes and intersection modifications to increase their capacity.

The feasibility of an interchange at Huntington Drive has been investigated and found to be possible in engineering terms for the three typical alignments. The interchange could be free-flow or signalized and serve all four directions including to and from the north, and to and from the south. Each ramp would involve open cut sections near the surface as they left Huntington Drive, transitioning to short sections of cut and cover tunnel before entering the main ramp

tunnels that will likely use Sequential Excavation Method (SEM) excavation (each ramp assumed to be two lanes wide with shoulders).

At the surface, the interchange would require additional right-of-way acquisition. The layout of the interchange would be dependent upon the final identified traffic requirements and Caltrans' required standards.

The addition of the interchange would also impact the ventilation system for the tunnel, which would become essentially two additional tunnels from this perspective with the further addition of four separate ramp tunnels. This would involve the addition of probably two ventilation buildings and stacks to be located somewhere near the two merge zones where the ramps meet the main tunnels. The ventilation system with an interchange would be more complex and require detailed assessment before confirming the exact requirements. Potential sites for ventilation buildings and stacks would be one of the subjects of a detailed alternative analysis at a later stage aimed at minimizing the impacts involved.

Where the ramps merge with the main tunnel, extensive underground caverns would become necessary. In the case of cross-section option A1, breaking out the main TBM driven tunnel's concrete lining and extending the tunnel sequentially to form a chamber of over 80 feet span, would be required to merge as one lane to enter the main line tunnel. As this cross-section has two traffic decks, it has been assumed that the merge would be on the upper level and for autos only. In this case, the traffic and signage design would need to permit traffic to access required lanes to allow that movement with safety and convenience.

The ramp tunnels would also require emergency access/egress shafts at 600 foot intervals with small surface rooms to house the stairwells and possibly elevators. Finding suitable locations for these shafts would also influence the ramp alignment.

It is concluded that construction of this merge cavern is likely feasible using currently available tunneling techniques. It may prove more cost effective to combine this merge chamber with the additional ventilation buildings, within a deep structure within open cut, constructed from the surface. It would require more detailed investigation at a later stage.

In the case of the SEM mined main tunnel (cross-section option A2), the addition of the merge would require an increase to the main tunnel to around 100 feet span, which is outside currently anticipated advances in tunnel engineering. However this might similarly be constructed in conjunction with the additional ventilation buildings, and could be investigated further once more detailed knowledge of the ground conditions became available.

Similarly, the cross-section option B2 with a span requirement of around 110 feet is outside currently anticipated advances in tunnel engineering. Cross-section option C2 with a span of 100 feet may fall nearer to the limit of current excavation limits in the anticipated ground conditions,

For the cross-section option 3, the outer 2-lane tunnels would accommodate the ramp tunnels. The stacked center tunnel would not have access to the interchange. Similarly, cross-section

options B3 and C3 would also offer more easily achieved interchange with the outer 2-lane tunnels.

If it is decided that the interchange would be required, then these aspects will require more investigation in detail.

## 7.0 Architectural Renderings

Consideration has been given to developing some initial architectural design concepts for the surface project elements to explore typical treatments that might be considered in developing architectural designs at some later stage of development of the project.

A survey of tunnel design features from around the world revealed a variety of approaches to designs of surface elements such as portals and ventilation buildings. It revealed a range of designs that demonstrated regional styles and a wide range of project budgets devoted to these elements. This has produced designs that vary from utilitarian, industrial style buildings and structures to others that attempt to minimize impacts or incorporate landscape and textural elements.

The Type A, “Portal Wall” dominant options shown in Figure 7.1, is taken from completed tunnels in Europe, Asia, Australia and the USA. Many are characterized by bold, “high tech”, typically curvilinear forms expressive of their function and the materials from which they are constructed. Some incorporate landscape elements to soften and conceal ventilation and spaces to house other functional tunnel related systems.

Combined with their large scale, these forms are associated with dramatic architectural statements, dominating their surroundings. There is some variation between tunnels that are funded by public funds and others that have adopted more dramatic forms and cladding styles for privately funded operators under franchise agreements, particularly in Asia.

For the Route 710 tunnel the portals would be located in densely developed residential and commercial areas and at this stage the renderings produced attempt to demonstrate typical concepts that might initiate thinking to the possible range of designs that might be suitable for portals and various tunnel related buildings that would be required. For this project, Type B – “Landscape” dominant options shown in Figure 7.2, in contrast, defer to and blend with their surroundings. Prototypes for these are abundant in southern California, where our climate has inspired and facilitated the creation and development of architectural styles, fully integrating buildings and vegetation into unique “context sensitive” designs.

The project area is particularly abundant in examples of these styles, most notably the “Arroyo Craftsman” traditions originating in the early 20<sup>th</sup> century and carried forward into contemporary work in the surrounding communities, and work inspired by the work of the architectural master F. L. Wright, also originating in the early 20<sup>th</sup> century, and carried forward in contemporary work. Both of these styles make use of architectural scale, massing, surface material, texture and color to blend with their surrounding landforms, native oak and sycamore habitats, and introduced Mediterranean landscape styles, characterized by skyline eucalyptus trees and a wide array of subtropical flowering plants.

It is intended that the initial ideas shown here would serve as a catalyst to a far wider examination of designs for the portals, ventilation and other tunnel operational facilities that would be required if the project progresses. This “Context Sensitive Design” approach is illustrated in the accompanying renderings.

## **7.1 Portals**

### **7.1.1 Type A Portal Wall Dominant Options**

The Type A options are characterized by bold, “high tech”, curvilinear forms expressive of their function and the materials used. Some incorporate landscape elements to soften and conceal ventilation and spaces to house other functional tunnel related systems. These forms are associated with large scale, dramatic architectural statements, dominating their surroundings.



**Figure 7.1 Tunnel Portal Prototype Images**

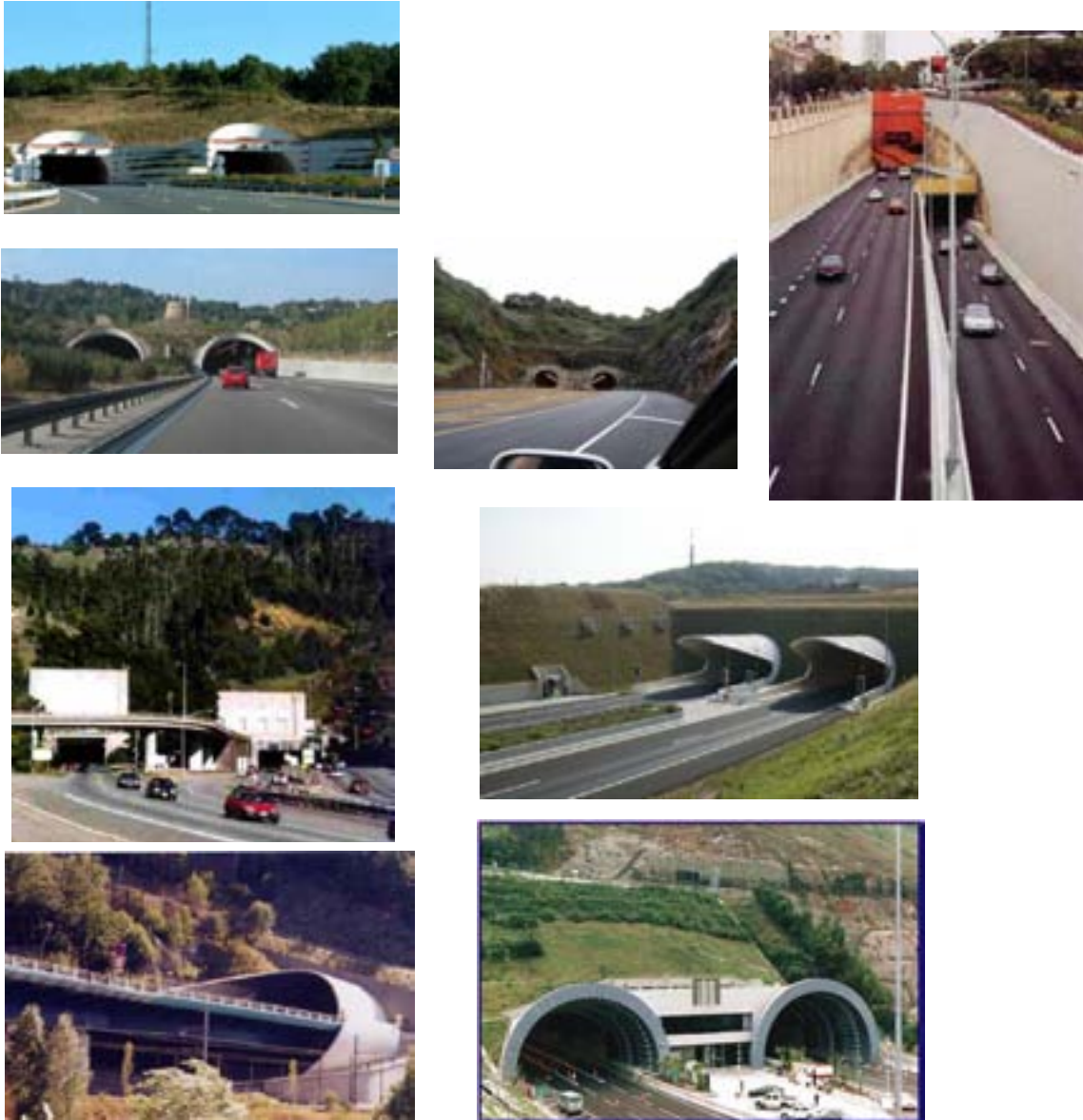

### **7.1.2 Type B Landscape Dominant Options**

“Landscape” dominant options defer to and blend with their surroundings in Southern California, where our climate has inspired and facilitated the creation and development of architectural styles, and fully integrate buildings and vegetation into unique “context sensitive” designs.

Figure 7-1 Landscape Prototype Images



### 7.1.3 Portal Renderings

**Figure 7-2 Portal Option 1**

This sketch illustrates a view of simple arched portals in a landscape dominant context.



**Figure 7-3 Portal Option 2**

This sketch also illustrates a view of portals in a landscape dominant context, structurally integrating the portal with the surrounding landforms by incorporating vertically and horizontally stepped portal headwall elements.

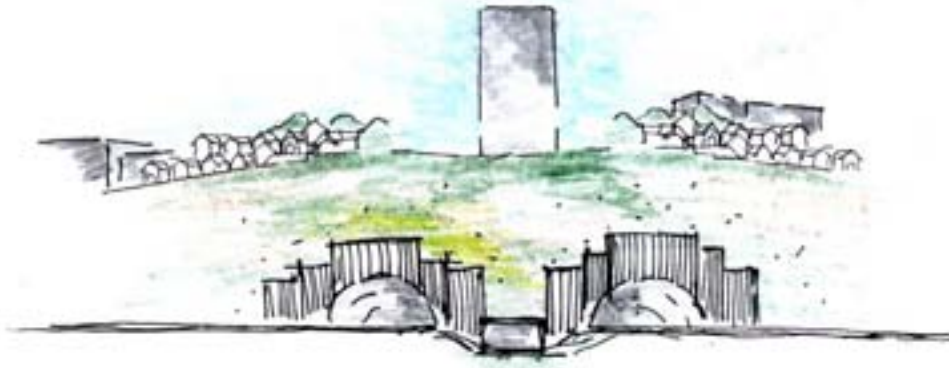

**Figure 7-4 Portal Option 3**

This sketch illustrates a further integration of portal headwall elements and the surrounding landscape by adding plantings to the stepped portal terraces.

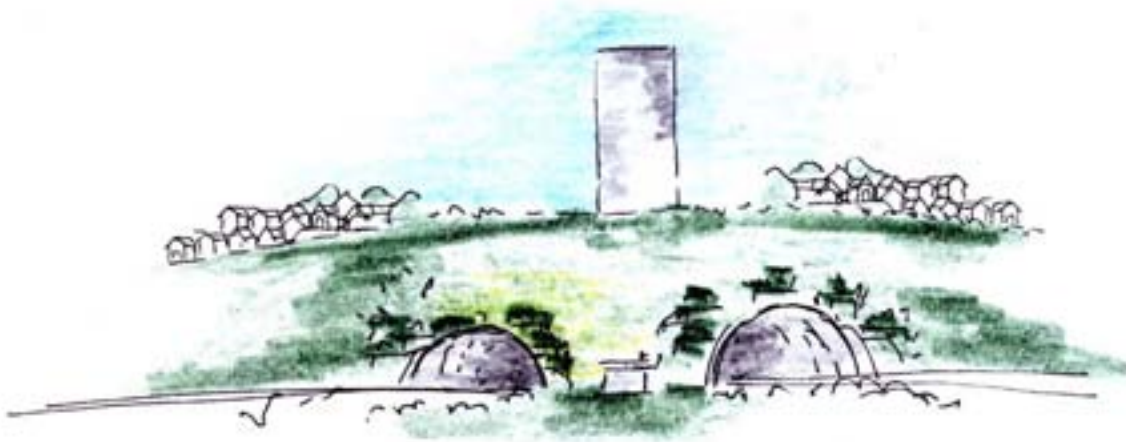



**Figure 7-5 Portal Option 4**

This sketch illustrates a landscape dominant arch portal design, with stepped elements



**Figure 7-6 Portal Option 5**

This sketch illustrates a landscape dominant “hybrid” arch and stepped planted terrace design, maximizing integration of structures, surrounding landforms, and planting.



**Figure 7-7 Portal Option 6**

This sketch illustrates a landscape dominant integration of the Tunnel Portal Roadway Approach with its surroundings through landform and planting design.



**Figure 7-8 Tunnel Roadway Approach**

This sketch illustrates a landscape dominant integration of the Tunnel Portal Roadway Approach with its surroundings through landform and planting design.



### **Tunnel Ventilation Structures**

**Figure 7-9 Ventilation Tower Profile 1**

This Sketch illustrates a typical above ground cross section of a tunnel ventilation structure, showing relative heights of surrounding trees planted a varying distances from the structure, and human scale figures. Skyline palms, eucalyptus and conifers can equal or exceed the 100 foot height of the tower, and massed plantings of local native trees such as Live Oaks can screen sight lines from surrounding properties.

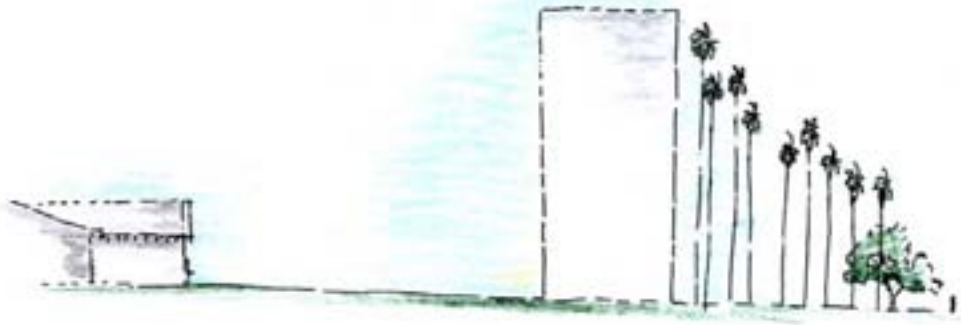

**Figure 7-10 Ventilation Tower Profile 2**

This sketch illustrates an example of a ventilation tower blended into the local landscape context through a veil of screen tree planting and architectural detail compatible within an historic context of Mediterranean architectural style. In this example, scale of architectural design detail elements is used to further integrate the tower into the surrounding environment.





**Figure 7-11 Ventilation Tower Profile 3**

As in the example shown in Figure 10, this sketch illustrates an example of a ventilation tower blended into the local landscape context through a veil of screen tree planting and architectural detail. In this example, the prototype is derived from the late 19<sup>th</sup> and early 20<sup>th</sup> century water towers common in the area.

**Figure 7-12 Ventilation Tower Profile 4**

This sketch illustrates in both plan and elevation views, how planting of trees of varying types and heights at varying distances from a tower will screen views from surrounding locations.



**Figure 7-13 Ventilation Tower Profile 5**

This sketch illustrates a more developed example of a ventilation tower blended into the local landscape context through a veil of screen tree planting and architectural detail. In this example, the prototype is derived from the late 19<sup>th</sup> and early 20<sup>th</sup> century water towers and incorporates craftsman style detailing and a clock element.



**Figure 7-14 Ventilation Tower Profile 6**

This sketch also illustrates a more developed example of a ventilation tower blended into the local landscape context through a veil of screen tree planting and architectural detail. In this example, the prototype is influenced by the landscape inspired approach developed by the early 20<sup>th</sup> Century architectural master F. L. Wright, and carried forward in contemporary work.



**Figure 7-15 Ventilation Tower Landscape Feature**

This image illustrates the potential of dense massing of Washington Palms to provide screening of tower and other infrastructure elements.



**Figure 7-16 Ventilation Tower w/ Cross Section**

This sketch illustrates the relative scale and relationships of tunnel, ventilation infrastructure and tower elements.

Ventilation infrastructure and towers are located at near the portals at each end of the tunnel, and at a location near the tunnel midpoint. Only the ventilation tower element would extend above ground at each location.

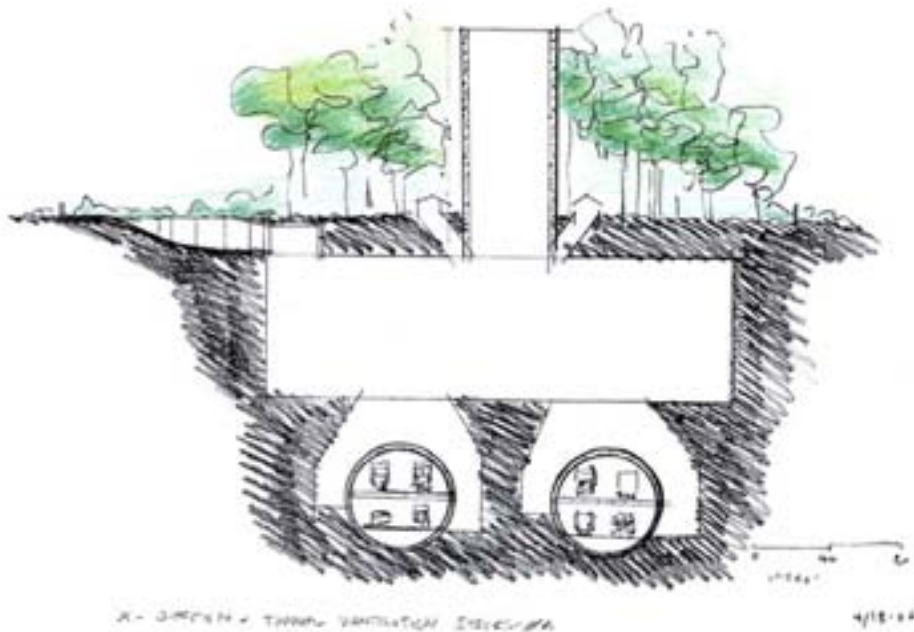

**Figure 7-17 Ventilation Tower- Bird's Eye View**

This sketch illustrates a bird's eye view of a typical ventilation tower.



This Page Intentionally Left Blank

## **8.0 Preliminary Environmental Analysis**

### **8.1 Introduction**

The preliminary environmental analysis under this study has not sought to provide an environmental document. This chapter summarizes the preliminary level of environmental analysis based upon early assumptions of the project description to support the feasibility study and to identify any potential key issues associated with the feasibility of any tunnel alternative to complete the Route 710 'gap'. If it is decided to explore a tunnel option in more detail, then the subsequent changes in project description, alignments, or environmental laws would require a more detailed evaluation of the issues raised under this initial study, with formulation of a comprehensive mitigation strategy.

Preliminary Environmental Analysis for the conceptual Route 710 tunnel alternatives has considered the existing conditions, the environmental constraints, the potential impacts that could occur within the immediate Route 710 tunnel study area and also regionally, and suggested typical mitigation measures, all of which would require further examination if the tunnel option is more fully investigated.

### **8.2 Existing Conditions**

The following subsections provide a review of the different environmental resources that are in the project study area.

#### **8.2.1 Noise**

Within most of the project study area are residential streets which provide a quiet environment. Noise-sensitive residential uses in the vicinity of the project study area include mixed residential and industrial near the southern portal located north of Valley Boulevard, residential areas near the potential interchange at Huntington Drive, and a mixture of residential and commercial near the northern portal. Currently, motor vehicles and trains are the two major noise sources in the project study area. Impacts to the regional network beyond the study area and mitigations in regional context may need to be considered in future studies.

#### **8.2.2 Air Quality**

The project study area is located in Los Angeles County, within the South Coast Air Basin (SCAB), which is governed by the South Coast Air Quality Management District (SCAQMD). The Clean Air Act (CAA) defines National Ambient Air Quality Standards (NAAQS) for six criteria pollutants that have adverse effects on human health. The South Coast Air Basin (SCAB) is designated as non-attainment for carbon monoxide (CO), particulate matter smaller than ten microns (PM<sub>10</sub>) and fine particulate matter smaller than two and one-half microns (PM<sub>2.5</sub>), and both the 1-hour and 8-hour ozone (O<sub>3</sub>) standards because the area exceeds the

established limits. The State of California, as permitted by the Clean Air Act, has also established California Ambient Air Quality Standards (CAAQS), which are generally stricter than the federal standards. The SCAB is designated as non-attainment for PM<sub>10</sub> and PM<sub>2.5</sub>, and ozone and is designated as unclassified for hydrogen sulfide and visibility reducing particles. The project study area is located in a non-attainment area that frequently exceeds national ambient air quality standards. The SCAQMD monitors air quality in the general project area at the Pasadena South Wilson Avenue monitoring station. According to the most recent data for this station, 2005 hourly O<sub>3</sub> levels exceeded the national standard on two days and CO was within the national standard during 2005. PM<sub>10</sub> and PM<sub>2.5</sub> are not monitored at this station but are monitored at the City of Los Angeles North Main Street station. The 2005 PM<sub>2.5</sub> levels exceeded the national standard on two days. PM<sub>10</sub> was within the national standard in 2005.

The air pollutants to consider for analysis of this project study include CO, PM<sub>10</sub>, PM<sub>2.5</sub>, and diesel particulate matter (DPM). Particulate matter from diesel-fueled engines has been identified as a toxic air contaminant (TAC) by the California Air Resources Board (CARB) and DPM is considered a TAC under California's air toxics program. These air pollutants could be compared with the applicable national ambient air quality standards (for CO and PM<sub>10</sub>), and CARB guideline values (for DPM).

### **8.2.3 Land Use**

The project study area traverses the Cities of Los Angeles, Alhambra, South Pasadena and Pasadena in the San Gabriel Valley. It is located in an urban city context with land uses consisting of single and multi-family residential, public facilities, open space, industrial manufacturing, and general commercial uses. Within the City of Los Angeles, the project study area is located in the North East Los Angeles Area Community Plan and the neighborhoods of El Sereno and Monterey Hills. Land use adjacent to the southern portal location is mostly industrial with some residential; whereas land use adjacent to the northern portal location is a mix of residential and some commercial. Generally, land use along the alignment would be residential, with mixed commercial and retail along sections of the main corridors such as Huntington Drive, Fremont Avenue and Fair Oaks Avenue, and some areas with educational and community uses.

### **8.2.4 Historic Properties**

The project study area has a rich cultural history. Modern cultural history of Los Angeles dates to the establishment of the pueblo (town) in 1781 by a Spanish Expedition. A number of historic structures or districts are listed or eligible for listing on the National Register of Historic Places. These include the following:

- Arroyo Seco Parkway, Pasadena Freeway
- Short Line Villa Tract Historic District, Los Angeles (El Sereno)
- South of Mission Historic District, South Pasadena
- South Pasadena Historic Business District, South Pasadena
- North of Mission Historic District, South Pasadena



- Oak Lawn District, South Pasadena
- Pasadena Avenue Historic District, South Pasadena
- Markham Place Historic District, Pasadena

Due to the established age of the area, structures that are over 50 years old may need to be analyzed to determine if they may be eligible for listing on the National Register of Historic Places. In addition, the Section 4 (f) related to parkland and recreational land uses is discussed in 8.2.8.

### **8.2.5 Archeological Impacts**

The cities of Los Angeles, Alhambra, South Pasadena and Pasadena have a rich history and culture with remnant evidence of native habitation prior to the arrival of the Europeans. The city of Pasadena falls within the Gabrielino territory and South Pasadena has served as a gateway to travel and commerce for aboriginal peoples. Pre-historic archaeological sites have been identified within the cities of Los Angeles and Pasadena.

### **8.2.6 Hazardous Materials/Waste**

There are some facilities within the project study area that handle, use, and/or store hazardous materials and/or waste. Sources of hazardous materials/waste include any potential leakage from hazardous waste sources (such as an underground storage tank at a gas station), which may leach into the adjacent soil and/or groundwater. Other potential sources located within the study area include older homes (such as lead based paint and asbestos) and traffic striping.

### **8.2.7 Storm Water and Drainage**

The project study area is located within the Los Angeles River Watershed over four basins: the Laguna Channel, Alhambra Wash, Arroyo Seco Channel and the Alhambra Avenue Drainage (a land area of over 834 square miles).

Three main types of water sources that would need to be considered during design of the tunnel include: groundwater seepage into the tunnel, storm water discharge during rain events, and maintenance of the tunnel (cleaning). Shallow borings, conducted in 1999 all encountered groundwater between approximately 10-14 m depth during the winter, near the boundary between Quaternary alluvium and bedrock. The tunnel drainage system would be needed for the collection and discharge of groundwater seepage and water used to clean and maintain the interior of the tunnel to a sanitary sewer, and run-off to storm water drains.

### **8.2.8 Parklands and Recreational Facilities**

Section 4(f) of the federal Department of Transportation Act of 1966 prohibits use of any publicly owned land from a public park, recreation area, wildlife refuge, or historic sites unless there is no feasible and prudent alternative to the use of such land or the project includes measures to minimize harm.

The Federal Highway Administration released a “Revised FHWA Section 4(f) Policy Paper” on March 2, 2005, which included the revised guidance that tunneling under the above mentioned land would be subject to the requirements of Section 4(f) if one of the following three circumstances occurs:

- Disturbs any archaeological sites on or eligible for the National Register of Historic Places which warrant preservation in place
- Causes disruption which would permanently harm the purposes for which the park, recreation, wildlife or waterfowl refuge was established
- Substantially impairs the historic values of the historic site.

A number of parks and recreational facilities are located within the project study area. Further investigation is needed in future phases of the project to determine whether Section 4(f) will apply. Local parks and recreational sites in the vicinity include the following:

- Sierra Vista School Playground, Los Angeles (El Sereno)
- South Pasadena High School Playing Field, South Pasadena
- South Pasadena Library Grounds, South Pasadena
- Orange Grove Park, South Pasadena
- El Centro School Playground, South Pasadena
- Singer Park, Pasadena

### **8.3 Environmental Constraints**

Environmental constraints that might impact the feasibility of the tunnel alignment are discussed below.

#### **8.3.1 Location of Portals**

Identifying the portal locations would be a critical decision with the potential to have a number of different environmental impacts. These impacts include those from traffic noise, air quality levels, and visual impacts.

##### *Traffic Noise*

At the tunnel portals, there is a potential to increase traffic noise because of the hard sound reflective surfaces of the tunnel portal that would amplify the traffic noise. The project can be designed to control and minimize traffic noise by using sound absorptive finishes and treatments at the tunnel portal surfaces. The landscape and site formations would need to integrate identified noise mitigation within the constructed features and landscape design after a full environmental analysis.

### *Air Quality Levels*

At the entrance or exit of the tunnel, there is a potential for concentrations of air pollutants, such as carbon monoxide and Diesel Particulate Matter, PM 2.5.

Air emitted from a tunnel may form a plume of pollutants discharged by vehicles using the tunnel leading to emissions that could reduce air quality locally, include the emissions from the following sources:

- Emissions exhausted out of the tunnel portal and tunnel portal mechanical ventilation fan buildings
- Emissions from the vehicles traveling on roadways immediately downstream of or approaching the portals
- Emissions from the traffic on the nearby street network
- Background levels appropriate for the area

### *Visual Impacts*

The portals and the approach highway would present new physical structures within the existing visual environment. Such visual constraints would require integration into the surrounding community. In particular the use of context sensitive design would need to be considered within residential areas which are usually “small-scale” in design and include pedestrian oriented features and facilities such as landscaped setbacks and tree-lined avenues. The visual mitigations could include landscape berms and banks and plantings. Some initial examples are included in Chapter 7 to serve as starting point for future study.

### **8.3.2 Ventilation Buildings and Shafts**

The operation and maintenance of the ventilation buildings and shafts have a potential for environmental impacts.

### *Noise*

The tunnel will require ventilation fans that would be operated during normal conditions to provide continuous ventilation to the tunnel and to control smoke during emergency conditions. Under normal operating conditions and testing conditions the fan noise would be subject to the requirements of the local or county noise ordinance. They are not subject to any noise level limits when operated during an emergency. To control fan noise, the design of the ventilation system should allow adequate space for sound attenuators both on the intake and discharge sides of the ventilation fans.

### *Air Quality Levels*

Ventilation stacks above ground would help to discharge and disperse air pollutants from within the tunnel. The potential constraint is the location of the ventilation shaft relative to sensitive receivers and the height of the shaft to adequately disperse and reduce pollutant concentrations of CO, PM<sub>10</sub>, and Diesel Particulate Matter.

At the ventilation shaft, there is a potential for concentrations of air pollutants on nearby receptors (both ground level and elevated) and the downwash effects from the nearby buildings. Therefore, the location of the ventilation shaft potentially has significant impacts on the adjacent land uses (e.g., residential buildings, parks, industrial, etc.).

As the tunnel ventilation system will “concentrate” the vehicle emissions over the length of the tunnel, the design should consider the location and height of discharge to achieve a maximized atmospheric dispersion.

A number of highway tunnels around the world have included Electrostatic Precipitators (ESPs) or “Scrubbers” to address problems related to particulate matter. Scrubber systems only remove Particulate Matter and thus ESP technology only addresses part of the emissions picture. The use of Scrubbers in other countries is the result of circumstances that do not exist in the United States such as a high percentage of diesel vehicles in the vehicular fleet or roadway dust created by studded tires pulverizing the road surface.

### *Visual Impacts*

Ventilation buildings and shafts would introduce physical structures within the existing visual environment. It is anticipated that a ventilation building and vent shaft will be located at both portals and near the mid-point of the proposed tunnel. The ventilation building near the portals would be integrated with the portals or in close proximity to the portals. The vent shafts are anticipated to be required at around 100 feet high, about 10 stories above the nearest sensitive receptor. This major vertical feature could represent a significant visual component that may be out-of-character with other structures in the area. The use of context sensitive design would be needed to integrate the ventilation buildings into the surrounding visual environment, primarily developed with 1- to 2-story structures.

### **8.3.3 Construction Related**

Environmental impacts may occur during the construction of the tunnel.

#### *At Surface Activities*

On the ground surface, construction related constraints include noise and particulate matter coming from the operation of diesel powered equipment for the portal and ventilation building construction. Another constraint is the on-going construction operations at the staging areas. Noise and vibration levels may occur during construction at sensitive receivers along the project

alignment, especially at the portals, ventilation building(s), and potentially at any interchange with Huntington Drive. To support underground tunneling, some surface activities could require 24-hour continuous operations such as removing tunnel spoils and temporary ventilation systems.

#### *Below Ground Activities*

Below the ground surface, construction related constraints include those related to the tunnel excavation. Two primary methods of subsurface excavation have been considered as part of this technical feasibility assessment. These methods are Tunnel Boring Machine (TBM) and Sequential Excavation Method (SEM), which are described in Chapter 4. Both methods will create ground-borne noise and ground-borne vibration associated with underground construction activities. These disturbances may be perceptible at the surface; however, they are limited to the duration of the local excavation activity. Another constraint could be the method chosen to remove the tunnel spoils during excavation either rubber tired vehicle or a steel wheel and rail muck train.

### **8.4 Potential Impacts that Could Occur and Typical Mitigation Measures**

This section describes the typical environmental impacts that may occur and the typical types of mitigation that could be used to avoid, minimize or mitigate those impacts.

#### **8.4.1 Noise**

##### *During Construction*

Temporary noise barriers can be used to reduce construction noise levels from equipment operating at the surface. Consideration should be given to determine whether permanent noise barriers should be implemented initially if they provide the appropriate level of mitigation of future operation noise as well as construction activity noise. Construction activities during nighttime hours will be subject to noise level limits based on the existing ambient levels. No significant impacts are expected.

##### *During Operation*

Noise impacts during the actual operation of the tunnel are not anticipated to be above established noise thresholds as methods can be utilized to minimize noise levels. Soundwalls and sound absorptive treatments would be used at the portals to decrease the extent of noise emanating from the portal areas.

Sound attenuators for ventilation fans and tunnel portal jet fans would be used to reduce noise levels to the areas around the ventilation buildings to meet the level permitted by the local noise ordinance. The ventilation fan buildings have been assumed to be located beneath ground level to reduce impacts.

Additional traffic that would be circulated to surrounding roadways (I-10, SR 134 and I-210) beyond the study area would not result in any increased noise at these locations. The maximum traffic noise would occur at roadway capacity (1950 vehicles/lane/hour) operating at a free flow condition of Level of Service (69 miles per hour). Additional traffic volumes exceeding capacity on these regional roadways would reduce travel speed effectively reducing noise levels. If further analysis of the traffic increases shows an increase in noise impacts on surrounding roadways in the network, noise mitigation measures can be explored in detail during the environmental/design stages of the project.

### **8.4.2 Air Quality**

#### *During Construction*

Typically, project related construction impacts would be localized, and predominant emissions would be nitrogen dioxide, carbon monoxide, sulfur oxides, and diesel particulate matter from diesel powered construction equipment; carbon monoxide emissions from worker vehicles, and PM<sub>10</sub> or dust emissions from vehicles traveling on unpaved surfaces, or as a result of grading and other earthmoving activities.

There could be substantial PM<sub>10</sub> emissions associated with excavation and tunneling activities (grading, excavation, creation of storage piles, loading of material onto haul trucks, etc.).

Implementing a fugitive dust program that could include measures such as site wetting and other controls would minimize impacts of construction. Maintenance of construction equipment emissions control systems could also be implemented to reduce construction impacts. It is anticipated that the application of these standard measures would reduce construction related air quality impacts to below a level of significance.

#### *During Operation*

Potential impacts of the vehicular emissions would be generated within the proposed tunnel and would be released to the atmosphere through the tunnel's two portals and the ventilation stacks. CO, PM<sub>2.5</sub>, PM<sub>10</sub>, and DPM are pollutants of concern for this analysis. Particulate matter and diesel particulate matter would be considered because of the diesel vehicles that may travel through the tunnel.

The significance of localized project impacts depends on whether predicted CO, PM<sub>2.5</sub> and PM<sub>10</sub> levels in the vicinity of the portals would be above or below the NAAQS and whether the projected increases in DPM near the tunnel portals would be above or below the SCAQMD's significant impact threshold.

If air pollutant levels were found to exceed these standards and thresholds, then the following potential mitigation measures would be considered:

- Raising the height of the ventilation shafts to increase atmospheric dispersion.

- Relocate ventilation shafts away from areas of sensitive land use.
- Revise the ventilation system to minimize the discharge at the portals.
- Modify the ventilation system at the portal to increase dispersion.

### **8.4.3 Historic Properties**

#### *During Construction*

It is not anticipated that the Route 710 Tunnel project would require loss or removal of any historic structures. Potential impacts to historic properties could occur in relation to ground vibration and settlement during the excavation of the tunnel under historic properties and/or historic districts. This potential impact would be greater with shallower tunnel depths occurring near the portal locations.

It is anticipated that the ventilation structures could be located such that they avoid impact to historic structures. However, if Huntington Drive interchange were included this might pose more constraints due to its close proximity to the historic districts. If it were decided to proceed with an interchange at Huntington Drive, more vibration impact may occur at the Short Line Villa Tract Historic District.

The potential ground vibration impact would be temporary in nature as the tunnel boring machine passed underneath the historic property and/or historic district. Different construction techniques and building protection can be utilized to protect and minimize vibration and settlement to these structures.

No impacts on historic properties are anticipated beyond the actual tunnel corridor.

#### *During Operation*

The operation of rubber-tired vehicles within the tunnel would result in imperceptible ground vibration levels to the historic properties above. No impacts would be expected.

### **8.4.4 Aesthetics**

The tunnel portal structures and ventilation buildings and shafts are large-scale structures that could have a major visual and aesthetic impact on the surrounding communities. Aesthetic treatments to the structures themselves, such as decorative architectural features and incorporation of art can be included in the design of the tunnel and associated structures to decrease their visual impacts and increase the aesthetics of their design. Softscape treatments such as landscape buffers, vegetated slopes and walls, and the conversion of remnant parcels into neighborhood parks can help blend the structures into the surrounding area, enhance the overall aesthetics of the surrounding area, and minimize visual impacts.

Architectural and urban designs for the portal structures, ventilation shafts, and surrounding areas should consider context sensitive design; visual quality; safety and operational requirements; security through environmental design; appropriate lighting; architectural treatments; and landscape interfaces. Workshops can be used to address key design issues with stakeholders. A focused community outreach and design process can help establish consensus on key design issues. A comprehensive landscape plan can be developed for integration of the physical structures into the surrounding community. The plan could incorporate features that meet the goals for aesthetic character and design for the area as established by the community's goals.

Some initial examples of portal and ventilation stack treatments are provided in Chapter 7 to indicate some potential mitigation ideas.

#### **8.4.5 Archeological Impacts**

Archaeological sites are not anticipated to be found within the project area.

#### **8.4.6 Hazardous Materials and Waste**

If hazardous materials are encountered during Geological boring activities, the cuttings would be properly disposed and the boring would be backfilled with bentonite grout. Any structures that would be demolished as part of construction will also undergo an evaluation for the presence of hazardous materials prior to demolition, in accordance with the Expedited Site Assessment (ESA) process.

Because dewatering activities may be necessitated by the proposed project, groundwater analyses will need to be performed, prior to issuance of the National Pollution Discharge Elimination System (NPDES) dewatering permit, to determine the type and extent of any hazardous materials/waste contamination.

#### **8.4.7 Disposal of Soil During Construction**

Another environmental impact relates to the disposal of soil during construction. Using trucks to haul soil to a landfill or other disposal site(s) via the freeway system would also have noise, air quality, and traffic impacts along the haul route. If the Union Pacific railroad spur is used (near the southern portal location) to remove the soil, the associated environmental impacts may be reduced.

#### **8.4.8 Storm Water Impacts**

Best management practices (BMPs) would be implemented during construction for storm water pollution control, in accordance with the National Pollutant Discharge Elimination System (NPDES). The project would need to comply with all Regional Water Quality Control Board's water quality standards and waste discharge requirements and Caltrans Statewide NPDES Storm Water requirements.



The proposed project would not create long-term demand for water. The demand for water during construction would be limited. The proposed project would not include any activities that would have long-term effects on local water sources; therefore, additional contribution of runoff water would not exceed the capacity of existing or planned storm water drainage systems, provide substantial additional sources of polluted runoff, or degrade water quality.

Some issues that may have significant impacts and will be studied at a later project phase include the following:

- Water quality standards or waste discharge requirements
- Depletion of groundwater supplies or interference with groundwater recharge or a lowering of the local groundwater table level
- Alteration of the existing drainage pattern of the site or area, which could result in erosion or siltation or increase the rate or amount of surface runoff which could result in flooding on- or off-site
- Creation or contribution to runoff water which could exceed the capacity of existing or planned storm water drainage systems or provide additional sources of polluted runoff
- Impacts on the physical, chemical, or biological qualities of water quality

## **8.5 Summary**

From the environmental perspective, the proposal to complete the Route 710 gap in the freeway system via a highway tunnel appears viable and feasible. The environmental impacts to the following resources may occur: noise, air quality, historic properties, aesthetics, archaeology, hazardous waste, soil disposal, and storm water impacts. However the severity of these impacts can be minimized, eliminated or mitigated. Based upon this preliminary environmental assessment, no insurmountable environmental impacts have been identified that would preclude further consideration of the tunnel alternative. However, it is recommended that additional detailed evaluations and analyses be conducted to determine the tunnel alternative including alignment, features and amenities that would be the most environmentally suited to the community and the Route 710 corridor.

The main environmental constraints to the tunnel concept are associated with the portal locations, the ventilation shafts, and the potential interchange at Huntington Drive. During subsequent environmental evaluation or additional conceptual planning for the tunnel alternatives, more detailed evaluations are warranted to identify the most appropriate strategies to minimize, eliminate or mitigate these impacts. It will be prudent to include an active public participation program to review concepts and provide feedback of the various project proposals.

This Page Intentionally Left Blank

## 9.0 Cost Analysis and Schedule

### 9.1 Introduction

A critical element in the determination of the feasibility of the tunnel alternative to close the Route 710 gap is the cost estimate. This study has included development of “Rough Order of Magnitude” (ROM) construction cost estimates for the tunnel construction alternatives. These cost estimates are commensurate with the conceptual level of design that has been developed for the purpose of this study. The estimates are based on a series of assumptions that are described in this Chapter. Given the very limited project definition at this stage, the assumptions are based on knowledge of similar constructed projects and the approach taken to construct those projects in terms of construction equipment, approach to excavation and disposal of spoil material and number of working faces, for example. If it is decided to pursue the project further then a more detailed costing evaluation will be necessary to identify options in the approach to construction and sensitivity of cost to changes in this approach.

The cost of the tunnel alternatives vary depending on the following options and elements:

- cross-sections (full standard versus reduced standard),
- configuration (single level, stacked dual level, two tunnels, three tunnels),
- length of the tunnel, based upon the three representative horizontal alignments.

Cost will also vary significantly with and without the option of a fully directional interchange at Huntington Drive. Other cost elements considered and included in these cost estimates include: major civil and structural features, tunnel finishes, support buildings to house tunnel ventilation equipment, control and operations buildings, roadway approaches leading into/out of the tunnel portals and new bridges and walls. Also included are the cross-passages between the tunnels for emergency access, and other emergency access/egress facilities and various tunnel electrical and mechanical systems.

Estimates of required right-of-way acquisition are not included. Much of the land that would be required to construct the portals is already under State ownership and very few new acquisitions, if any, appear necessary. The mid point ventilation buildings would require some land and ultimate selection of a site would need to consider the land impact and cost of any new acquisitions that are necessary. Other surface facilities such as the tunnel access entry buildings would be limited in size and may be possible within existing public right-of-way. The optional interchange at Huntington Drive has potentially greater right-of-way impacts and this can be investigated further if that option is adopted, when the location selection would consider state owned lots and impacts on local property.

Preliminary estimates of Operations and Maintenance costs have been estimated based upon similar costs at other highway tunnels within the USA.

The cost estimates are intended to establish the broad range of costs to construct the representative options so far considered and to help evaluate the financial viability of a tunnel concept versus other gap closure alternatives or other regional transportation priorities. Since there has been no decision up to this point to pursue the Route 710 tunnel option beyond this technical feasibility assessment, it is premature to speculate on the timing of construction. Consequently, these cost estimates are presented in fiscal year 2006 dollars and they have not been inflated to any future year of construction.

## **9.2 Methodology**

### **9.2.1 Study Alignment and Main Tunnel Elements**

This technical feasibility assessment has determined that the tunnel requires four lanes of traffic in each direction to provide an acceptable level of service in the year 2030. Thus, tunnel cost estimates in this document provide for four traffic lanes in each direction. Additionally, nine alternative tunnel cross-sections, as shown in Figure 6-1, were presented to represent the range of cross-sections for consideration. These nine alternative cross-sections were generated to reflect minor variations of three general tunnel configurations. The study has also considered three different representative horizontal alignment corridors, as shown in Figure 6.2 in Chapter 6 of this report.

Figure 6.1 represents a cross-section matrix showing the nine cross-section options developed for this study. As described above, these nine alternatives were derived from three general tunnel cross-sections. These general cross-sections are denoted as the “A” series of alternatives. Option A1’s cross-section features twin two-level tunnels with two lanes on each deck. The Option A1 alternative would be constructed using a Tunnel Boring Machine (TBM). Option A2’s cross-section provides twin single level four lane mined tunnels (constructed by SEM). The third general cross-section is Option A3, which provides the four lanes in each direction using three TBM constructed tunnels. The two outer tunnels are identical and provide for two lanes of traffic on a single level while the center tunnel is a larger diameter, two-level tunnel with two lanes of one-way traffic on each level. These general cross-sections were then modified to marginally reduce shoulder width and lane widths in corresponding Options B1, B2 and B3; and then modified again too minimize shoulder widths to get a fully reduced section to represent the lower end of the cost range in options C1, C2 and C3. Costs for each have been identified.

The representative horizontal alignments considered to get a range of costs are summarized in Figure 6-2 in Chapter 6 of this report. Alignment A approximately follows the previous surface Meridian alignment, Alignment B follows approximately along the line of Fremont, and Alignment C partially follows the Fair Oaks alignment. These alternative alignments yield tunnel lengths of approximately 21,163, 21,387 and 21738 feet respectively (that is between 4 to 4.1 miles).

One of the objectives of this feasibility assessment is to consider the feasibility of providing an interchange between the tunnel and Huntington Drive. Cost estimates for adding a fully directional (four ramps) arterial interchange to each of the nine alternative cross-sections

described above have also been developed. The tunnels were assumed to maintain a profile grade and depth approximately 100 feet below the surface and the ramps to and from Huntington Drive would connect the surface into the tunnel at depth. The interchange concept adds significant complexity to tunnel construction particularly where the ramps merge and diverge with the main tunnels, resulting in large cavern construction, which for some options, is judged beyond current capability in tunnel technology. Besides the complexity of these ramp/mainline tunnel confluence areas, the distance of the ramps are lengthy (over 1000 ft.) and each ramp represents essentially another individual tunnel. Consequently, a fully directional interchange will add another four smaller diameter tunnels to the cost estimates. The cost of a fully directional interchange has been estimated as additional optional feature for each tunnel alternative.

Tunnel Ventilation systems have been assessed for each case and the civil and structural works required for buildings and the underground excavation assumed necessary for those buildings has a significant cost, and this cost has also been assessed.

### **9.2.2 Tunnel Excavation Comparison**

Two main tunnel excavation methods and technologies have been considered for the development of the construction cost estimates. They are mining by Tunnel Boring Machine (TBM) and by Sequential Excavation Method (SEM). For cost estimation purposes, two base estimates have been made using Alignment B and cross-section options A1 and A2 to examine cost of TBM and SEM methods respectively. These two cross-section options form the baseline construction estimates.

For the remaining cross-section options, costs were "scaled" for the other diameters based on data obtained for large soft ground tunnels in the United States. These factors are not to be considered precise, as data is limited for very large tunnels. Rather, the scaled estimates would indicate a non-linear proportional changes related to the tunnel diameter. Items included in the scaling included the tunnels and elements of the portals.

### **9.2.3 Other Tunnel Cost Elements**

Other project elements considered in estimating the construction cost include the following:

- Ventilation System. The cost of a longitudinal ventilation system using Saccardo Nozzles is proposed for these tunnel alternatives. The cost estimate for this type of ventilation system includes the electrical and mechanical controls and other equipment associated with this system and noise attenuation systems. These costs have been assessed based on recent installation of similar equipment on comparable major highway tunnels and are included in the Mechanical & Electrical (M&E) systems costs.
- Other tunnel M&E systems, including Closed Circuit Television (CCTV) surveillance system, variable message signs, fire detection and suppression systems, air quality and visibility monitoring systems, HVAC for all ancillary spaces, lighting and lighting

controls, over-height vehicle detectors, OCC equipment, alarms including fire, security, intrusion, communications systems including telephones, power including emergency.

- Ventilation Structures at each of the two portals. These would be built immediately outside the TBM driven portal and possibly designed within the portal landscape and grading scheme.
- An underground mid-point ventilation building with ventilation stack is included to house fans and noise attenuators and damping systems to control flow of inlet and exhaust air.
- An allowance for Finishes within the tunnels such as paving, striping and wall cladding systems.
- Administration and Operations building assumed at the Southern Portal.
- Tunnel approach roads, including the approach ramps to channel traffic into the upper and lower levels in those options (A1, A3, B1, B3, C1, and C3) where some lanes are ‘stacked’ within the tunnel.
- New and replacement bridges to carry local street and railroad tracks over the tunnel approach roads at Valley Boulevard, Mission Road and for the railroad at the southern end of the project.

The ROM Cost Estimates based on the assumptions detailed above is summarized in Table 9-1. The costs are in Year 2006 dollars and the Table compares costs for each alignment and cross-section option considered. The additional cost of adding a fully directional (four ramps) interchange at Huntington Drive is also estimated along with the cost of additional buildings to house ventilation equipment.

### 9.3 Assumed Construction Schedule and Sequencing

As a basis for the tunnel estimate, the following assumptions were made on how the construction might proceed.

The main assumptions made for estimation of Option A1 along Alignment B - with four ramps and a combined mid-tunnel ventilation building over both main tunnels - are as follows:

- This option was estimated to require a nine year construction schedule, with tunneling works over three shifts per day, and five days per week. It was assumed that durations of 84 days to assemble and start TBM, and 45 days to remove and dis-assemble at the end of the drive, would be required.
- Portal construction would proceed with two shifts per day, five days per weeks, requiring a 17-month construction and excavation period, after an initial three months for mobilization and site preparation.
- It was assumed that two TBMs would need to be driven concurrently, one from north portal for one tunnel, and one from south portal for the other tunnel. Average production was assumed at 25 linear feet per day, based on a three shift per day operation. Work was initially assumed for five days per week, with a one maintenance shift on Saturday.
- In the anticipated fault zone area, after completion of the main tunnel TBM drive, it would be necessary to remove 1,500 ft of tunnel segment liners (for each bore) to allow

the over excavation though the faulted area and special construction of this zone before completion of new lining segments

- For the possible Huntington Drive option, it was assumed that all four ramps would be constructed, each with portion of open cut near the surface where it meets Huntington Drive and the remainder constructed by roadheader driven tunneling, including the tie-in to the main tunnel.
- A duration of 16 months was assumed to construct the upper roadway deck and lower roadway invert.
- It was assumed that an eighteen-month duration would be required to finish the permanent portal work, including construction of the concrete invert and walls, before construction of the portal ventilation buildings.
- For the Mid Tunnel Ventilation Building:
  - Slurry wall support was assumed for the excavation
  - The Excavation would be braced during soil excavation
  - To connect down to the tunnel, it was assumed that installation of raise-bore shafts for fan vertical shafts would be required and that the schedule for this activity would not commence until the tunnel was driven past this location to allow for installation of the raise-bore head.
  - Construction of the exhaust stack and air intakes above ground, and completion of the M&E installation and above ground access and landscape elements would conclude the ventilation building main construction activity
- A 15 per cent Design Contingency was added to the fiscal year 2006 construction cost at the direction of MTA.
- Cost Estimates are at base year of 2006 and do not include escalation to the mid-point of construction
- The initial schedule is included as Figure 9-1 and 9-2.

For the SEM excavated tunnel in Option A2, again along Alignment B, the assumptions also include the following key points:

- Estimate included a longer 11.5-year construction schedule, for this method with tunnel cavern excavation works needing four roadheader spreads at one time, five days per week.
- In this case the Portal Construction has again been assumed to proceed with two shifts per day.
- Roadheader mined excavation was assumed for mining the tunnel.
- After the tunnel construction, at the assumed fault zone, removal of some 1,500 ft of tunnel wall (for each bore) would be made before performing the over excavation for the seismic section.

- Concrete operations for the final lining, waterproofing and road deck would proceed from four headings.
- Cost does not include escalation to the mid-point of construction
- Schedule for the SEM option is outlined in Figure 9-2

For the optional Tunnel Interchange at Huntington Drive

For Interchange Ramp Construction:

- A delayed start was assumed, to allow for the TBM drive to go past the intersection, before it would be possible to mine the tie-in to the main tunnel;
- Open Cut was assumed at the Ramp portal areas alongside and connecting to the existing Huntington Drive;
- Roadheader mined excavation was assumed for mining the majority of the ramp tunnel lengths;
- Cast in place liner was assumed for lining these tunnels

**Items Not Included in the Estimates.**

The following is a list of items that are not included in the estimates:

- Toll collection systems and toll plaza facilities;
- Electrostatic precipitators;
- Right-of-way or any land-related costs;
- Reconstruction and improvement of additional local streets or distributor roads, including Huntington Drive;
- Utility Relocations;
- Soundwalls;
- Survey and Subsidence Remedial Work.



Figure 9-1 Schedule For TBM Construction

	TASK NAME	Year 1	Year 2	Year 3	Year 4	Year 5	Year 6	Year 7	Year 8	Year 9
1	Project Mobilization	■								
2	Portal Excavations	■	■							
3	TBM Installation at North and South Portals		■							
4	TBM Mining from North and South Portals			■	■	■	■			
5	North and South Tunnel Fault Zone Reconstruction						■			
6	Cross Passage Construction			■	■	■				
7	Tunnel Lining and Road Deck						■	■	■	
8	Build Out Portal & Approaches							■	■	■
9	Tunnel Vent Structures				■	■	■	■	■	■
10	Tunnel Finishes							■	■	■
11	Optional Tunnel Interchange			■	■	■				
	Project Demobilization – Heavy Civil Works									■

Figure 9-2 Schedule For SEM Construction

	TASK NAME	Year 1	Year 2	Year 3	Year 4	Year 5	Year 6	Year 7	Year 8	Year 9	Year 10	Year 11
1	Project Mobilization	■										
2	Portal Excavations	■	■									
3	Tunnels Excavation by Roadheader			■	■	■	■	■				
4	Tunnel Fault Zone Reconstruction							■				
5	Cross Passage Construction			■	■	■	■	■				
6	Ventilation Structures					■	■	■	■			
7	Tunnel Concrete Lining								■	■	■	
8	Tunnel Systems								■	■	■	■
9	Build Out North & South Portals/Approach								■	■	■	■
10	Tunnel Finishes									■	■	■
11	Optional Tunnel Interchange			■	■	■	■	■				
12	Project Demobilization – Heavy Civil Works											■

## 9.4 Operations and Maintenance

Operations and Maintenance (O&M) costs were based on actual and estimated road tunnel operating costs in other regions of the country. The estimate is based on the costs of O&M for much shorter (~4,000-5,000 ft) tunnels. However, the longer the tunnel, the lower per lane foot cost for some O&M costs, such as cleaning, safety patrols, traffic management etc.

Annual O&M costs were estimated to be approximately \$200.00 per lane foot. When applied to eight lanes over 21,000 ft, the annual operating costs are estimated to be \$33,600,000. The annual O&M costs include energy, personnel and equipment costs.

## 9.5 Summary of Cost Estimate

Table 9.1 Summarizes the Rough Order of Magnitude Construction Cost for all nine alternatives. These figures are construction cost estimates and do not include land costs and other items described in 9.4 above. The cost is in Year 2006 dollars with no escalation.

The estimated sums have been based on assumptions outlined in this chapter and if the actual approach to construction is different then it could impact construction costs. For example, if the number of TBMs used increased from the assumed 2 to 4 then this could change overall advance rates but this would need to be offset against the additional cost of 2 more TBMs. Much more detailed analysis of such aspects would be needed at a later stage of project definition.

It is also important to note that although the Year 2006 estimate for the TBM options (e.g. A1) appears close to the SEM options (e.g. A2), the construction schedule for SEM would be considerably longer resulting in higher actual cost for the SEM options.

In the use of either method the controlling factor on production rates may be governed by the rate at which excavated material may be removed from the site. Given the likely restriction on working hours, the volume of material translated into size of the handling facility and the numbers of trucks required to haul the material from the site, then the feasible disposal rate may determine the rate of excavation that is possible. Again, more detailed examination would be necessary as the project constraints became better defined.

The estimates are the preliminary and give a Rough Order of Magnitude for the construction cost.

Table 9-1 Estimate of ROM Construction Costs

Cross Section Option	Construction Estimate Total without interchange (Year 2006 \$Million - 15% contingency)	Construction Estimate Total with Interchange (Year 2006 \$ Million - with 15% contingency)
<b><i>Meridian Alignment A</i></b>		
A1	2,875	4,166
A2	2,882	4,173
A3	3,585	4,876
B1	2,860	4,152
B2	2,542	3,833
B3	3,460	4,752
C1	2,377	3,669
C2	2,282	3,573
C3	3,195	4,486
<b><i>Fremont Alignment B</i></b>		
A1	2,891	4,183
A2	2,900	4,192
A3	3,605	4,897
B1	2,875	4,166
B2	2,556	3,848
B3	3,479	4,770
C1	2,389	3,680
C2	2,294	3,586
C3	3,210	4,501
<b><i>Fair Oaks Alignment C</i></b>		
A1	2,919	4,210
A2	2,930	4,222
A3	3,639	4,930
B1	2,900	4,192
B2	2,582	3,873
B3	3,509	4,800
C1	2,409	3,701
C2	2,316	3,608
C3	3,235	4,526

## 10.0 Potential Funding

### 10.1 Purpose of Financial Strategy Report

The purpose of the report was to assist the LACMTA in identifying potential funding sources and funding scenarios for the future implementation of a Tunnel Alternative. This Financial Strategy Report provides a starting point for the development of the project's financial plan and, if it proceeds through the state and federal environmental and project implementation processes, completion of a comprehensive financial plan will be required. Additionally, since the initial order of magnitude construction cost estimate for the tunnel is \$3 billion (2006 dollars), the project would fall under the FHWA Mega Project classification which requires the development of a comprehensive financial plan, with annual updates on actual cost and revenue performance in comparison to initial estimates as well as updated estimates of future year obligations and expenditures, cost and revenue trends, current and potential funding shortfalls and the financial adjustments necessary to assure completion of the project.

### 10.2 Potential Funding Sources

Potential federal, state, regional, and local funding sources that could all be considered to finance the Route 710 Tunnel. As shown in Tables 10.1 and 10.2, over 25 federal, state, regional, and local funding sources were identified and screened to a more promising list of 14 potential funding sources.

#### 10.2.1 Federal Sources

The project is addressing issues of national and regional significance and should be considered a strong candidate for receipt of federal funding. Potential Federal Funding sources are summarized in Table 10.1 and discussed in detail in the Financial Strategy Report prepared under the Study.

**Table 10-1:  
Potential Federal Funding Sources for the Route 710 Tunnel Project**

FEDERAL SOURCES (Range 0%-48% of total funding)	DESCRIPTION	ADVANCED FOR CONSIDERATION
DEPARTMENT OF TRANSPORTATION - FEDERAL HIGHWAY ADMINISTRATION		
High Priority Project Earmark (Demo Funds)	Provides designated funding for specific projects identified in SAFETEA-LU.  Total in LA County: \$234.2 million for 158 projects, ranging from \$12.4 million (ACE) to \$12.8 thousand. Total in federal program: \$15 billion.  Includes \$2.4 million for study of 710 Tunnel Alternative.	<b>X</b>
Projects of National and Regional Significance	Discretionary program. Provides funding for high cost projects of national or regional significance. Projects selected by competitive evaluation process based on ability to generate national economic benefits, reduce congestion, improve safety, leverage non-federal funding, stability of financial plan, use of new technology, and maintain/protect the environment.  LA County: \$225 million for 2 projects (\$125 mil ACE; \$100	<b>X</b>

	mill Gerald Desmond Bridge). Total in federal program: \$1.8 billion.	
National Corridor Infrastructure Program	Discretionary program. Provides funding for construction of corridors of national significance to promote economic growth and international or interregional trade. Competitive selection process based on criteria including: extent to which corridor links two existing segments of the interstate system; facilitates major mobility, economic growth, development in area underserved by highway investment, significant commercial traffic; reduce commercial or other travel time through a major freight corridor.  Total in LA County: \$100 million for 1 project (I-405 HOV Lane). Total in federal program: \$1.95 billion.	X
Interstate Maintenance (IM) Program	Discretionary program. Provides for the on-going work necessary to preserve and improve Interstate highways. This includes funding for resurfacing, restoring, rehabilitating and reconstructing (4R) most routes on the Interstate System.  For FY 06, seven projects named in California with funding levels ranging from \$750,000 to \$1 million.	X
Highway Bridge Program	Discretionary Program. Provides funding to enable States to improve the condition of their highway bridges through replacement, rehabilitation, and systematic preventive maintenance.	
Federal "Core" Programs: Surface Transportation Program (STP) National Highway System (NHS) Highway Safety Improvements	Funds are distributed through the STIP and SHOPP. For STIP, 75 percent of funds are programmed at discretion of the MPOs (e.g.-LACMTA) in RIP and 25 percent by Caltrans in IIP. Of these, 88.53% are federal.  Total in LA County: STIP: \$904.1 million; IIP: \$152 million.	(see STIP and IIP. Programmed at discretion of LACMTA and Caltrans, respectively)
Congestion Mitigation and Air Quality (CMAQ)	For projects that improve air quality and reduce congestion. Funds are programmed by LACMTA for bus/rail capital, highway (HOV,TSM, Fwy, and Call projects), bus/rail operations (first 3 yrs of start-up).  Total in LA County: \$824 million.	X (Programmed at discretion of LACMTA)
Transportation, Community, and System Preservation (TCSP) Program	Competitive program with funds earmarked for projects that integrate transportation, community, system preservation, and the environment. Limited levels of funding total and by project.	(minimal funding)
Transportation Enhancement Activities	For bicycle, pedestrian, transit, landscaping, public art, or historic projects linked to transportation. Limited levels of funding (generally under \$5 million) are available per project.	
Transportation Infrastructure Finance and Innovation Act (TIFIA)	Provides 3 forms of credit assistance - loans, loan guarantees, and standby lines of credit - to projects of national or regional significance exceeding \$50.00 million in cost. Federal share cannot exceed 33%. Credit must be supported in whole or in part by user charges or other dedicated non-federal sources. Must be repaid within 35 years of project's substantial completion.	X
<b>DEPARTMENT OF TRANSPORTATION - FEDERAL TRANSIT ADMINISTRATION</b>		
Section 5307 Urbanized Area Formula Funds	Provides transit capital and operating assistance to urbanized areas. No or limited funding expected to be available for transit-related project components.	
Section 5309 Discretionary Capital Funds	Discretionary program. Provides capital assistance for new or extensions to fixed guideways, fixed guideway modernization, and bus/bus related facilities. Could potentially be pursued if transit guideway were part of the project.	

<b>DEPARTMENT OF DEFENSE</b>		
Military Construction Funds	Projects earmarked for funding in the annual Military Construction Appropriations bill and/or in the DOD's Future Years Defense Program (FYDP) for safety, health, environmental, and military utility. Could potentially be tied to 710 as link between the Ports and inland logistical bases.	

Source: Sharon Greene & Associates, May 2006.

### 10.2.2 State Sources

Four state funding sources were considered as potential funding sources: the Interregional Improvement Program component of the State Transportation Improvement Program (STIP), Grant Anticipation Revenue Vehicle (GARVEE) bonds, proceeds from potential future State infrastructure bonding, and proceeds from the sale of excess right-of-way previously acquired for the Route 710 Gap Closure at-grade alternative. Descriptions of these programs are in Table 10.2 below.

**Table 10-2:  
Potential State, User Fee, Regional and Local Funding Sources  
for the Route 710 Tunnel Project**

<b>STATE, USER FEE, REGIONAL, AND LOCAL SOURCES</b>	<b>DESCRIPTION</b>	<b>ADVANCED FOR CONSIDERATION</b>
<b>STATE SOURCES (Range 12%-20% of Total Funding)</b>		
State Transportation Improvement Program: Interregional Improvement Program (Cash)	25 percent of the federal and state funds in the State Highway Account funds are prioritized and programmed by Caltrans for projects of regional significance. These funds are programmed in the Interregional Transportation Improvement Program (IIP) component of the State Transportation Improvement Program (STIP).	<b>X</b>
STIP: Grant Anticipation Revenue Bonds (GARVEES)	Federal grant revenue anticipation bond proceeds pledged to projects. Annual debt service programmed in the STIP, with source from IIP (or RIP) funds.	<b>X</b>
Future State Bond Program or "Traffic Congestion Relief Program II"	Transportation program funded with future State bonds or future State funding initiative adopted by State Legislature	<b>X</b>
Sale of Parcels Previously Acquired (Excess Right of Way)	Special legislation required to apply funds from ROW sales to the 710 Gap Closure Project.	<b>X</b>
<b>USER FEES/TOLLS (0%-50% of Total Funding)</b>		

User Fees/Tolls (HOT lanes, truck lanes, general purpose traffic within larger 710 Corridor).	While used in many areas of the country, enabling legislation is required to authorize use of fees/tolls for individual highway projects within the State of California. Tolls could provide a mechanism to generate revenue, moderate traffic demand, and/or provide incentive to use particular facilities. Tolling could be part of an overall funding strategy with toll revenues providing part of a larger revenue stream pledged for debt repayment. Facility could be designed, built, and/or operated as public, private, or public-private partnership.  SAFETEA-LU offers States broader ability to use tolling on a pilot, or demonstration, basis to finance Interstate construction and reconstruction, promote efficiency in the use of highways, and support congestion reduction. Of particular relevance is the Interstate System Construction Pilot Program, which authorizes up to 3 toll pilot facilities on the Interstate System for the purpose of constructing new Interstate highways. Criteria include: tolling must be the most efficient and economical way to finance the project, but it doesn't have to be the only way. Automatic toll collection is required.	X
Regional Freight Fees	If part of larger goods movement network, could potentially be part of any program funded through container fees or other freight fee program.	
<b>REGIONAL SOURCES</b> (Range 28% - 50% of Total Funding)		
State Transportation Improvement Program: Regional Improvement Program (Cash)	75 percent of the federal and state funds in the State Highway Account funds are prioritized and programmed by regional agencies (such as LACMTA). These funds are programmed in the Regional Transportation Improvement Program (RIP) component of the State Transportation Improvement Program (STIP).	X
STIP: Grant Anticipation Revenue Bonds (GARVEES)	Federal grant revenue anticipation bond proceeds pledged to projects. Annual debt service programmed in the STIP	X
Proposition C Funding	Potentially eligible for funds under Prop C 25% Transit-related Street and Highway Improvements.	X
Future County Sales Tax	Project could be designated to receive funding under an interim multimodal countywide sales tax in the future.	X
<b>LOCAL SOURCES</b>		
Transportation Impact Fee (for Annual Debt Service)	Creation of Transportation Impact Fee, with fees pledged for payment of annual debt service	
Tax Increment Financing (for Annual Debt Service)	Creation of Tax Increment Finance District, with tax increments pledged for payment of annual debt service	

Source: Sharon Greene & Associates, May 2006.

### 10.2.3 Proceeds from the Sale of Previously Acquired Right-of-Way

#### *Description*

In preparation for the proposed at-grade alternative for the Route 710 Gap Closure, Caltrans had acquired approximately 700 parcels. While the specific alignment of a potential Route 710 Tunnel is yet to be developed, it is anticipated that a majority of these parcels would no longer be required. The excess parcels could potentially be sold and the revenue potentially be used for the Route 710 Tunnel project.

#### *Policy Considerations*

Existing State legislation precludes sale of the existing State-owned Route 710 right-of-way at fair market value. State legislation may also preclude proceeds being used for a specific project.



Thus, new State legislation would be required in order to sell excess right-of-way at fair market value and apply the proceeds from the sale to the Route 710 Tunnel project.

### ***Revenue Potential***

Based on current value, the proceeds from selling Caltrans' owned excess right-of-way in the amount of approximately \$500 million could be generated. The revenue potential provided is dependent on the magnitude of the value and the legal status of applying this value to the Route 710 Tunnel project.

## **10.2.4 Tolling**

### ***Description***

Bonds leveraged from anticipated toll revenue could potentially be a component of the funding and financing proposed. However, since cost data and traffic forecasts are only conceptual at this time, the toll revenue and bonding potential described below should only be considered as order of magnitude estimates. A number of assumptions which were used to generate order of magnitude toll revenue estimates are described in the Study's Financial Report.

Based on these assumptions, Table 10-3 (autos only use tunnel) and Table 10-4 (autos and trucks use tunnel) provide a range of potential toll revenue and level of bonding estimates. At this point of project development, the study team considers these ranges to be the maximum percent of total construction costs from toll revenue bonds that are feasible to include in the funding scenarios analysis in 10.3.

**Table 10-3:  
Order of Magnitude Toll Revenue and Level of Bonding Estimate – Autos Only  
(2006 dollars)**

<b>Assumptions</b>	<b>Toll Revenue Scenario 1</b>	<b>Toll Revenue Scenario 2</b>	<b>Toll Revenue Scenario 3</b>	<b>Toll Revenue Scenario 4</b>
Estimated Weekday Total Traffic	183,170	183,170	183,170	183,170
Estimated Truck Volumes	0	0	0	0
Estimated Auto Diversion Rate	20%	25%	30%	35%
Annualization Factor	320	320	320	320
Toll Rate - Auto	\$3.00	\$4.00	\$5.00	\$6.00
O&M Cost	\$28,000,000	\$28,000,000	\$28,000,000	\$28,000,000
Debt Coverage Level	1.5	1.5	1.5	1.5
<b>Estimated Annual Tunnel Traffic</b>				
Annualized Auto Traffic	46,891,392	43,960,680	41,029,968	38,099,256
<b>Estimated Tunnel Revenues</b>				
Annual Auto Revenue	\$140,674,176	\$175,842,720	\$205,149,840	\$228,595,536
<b>Estimated O&amp;M Costs</b>				
Annual O&M Cost Estimate	\$28,000,000	\$28,000,000	\$28,000,000	\$28,000,000
<b>Estimated Net Revenue</b>				

Annual Net Revenue Estimate	\$112,674,176	\$147,842,720	\$177,149,840	\$200,595,536
Available for Bonding (Coverage Rate 1.5)	\$75,116,117	\$98,561,813	\$118,099,893	\$133,730,357
Issue Bonds (13 times Available for Bonding)	\$976,509,525	\$1,281,303,573	\$1,535,298,613	\$1,738,494,645
Percent of Total Project (\$3 billion)	32.55%	42.71%	51.18%	57.95%
Additional Cost to Project (Interest on Bonds)	\$1,095,142,893	\$1,436,965,504	\$1,721,817,679	\$1,949,699,420

Source: Sharon Greene and Associates, May 2006.

**Table 10-4:  
Order of Magnitude Toll Revenue and Level of Bonding Estimate—Autos and Trucks  
(2006 dollars)**

<b>Assumptions</b>	<b>Toll Revenue Scenario 1</b>	<b>Toll Revenue Scenario 2</b>	<b>Toll Revenue Scenario 3</b>	<b>Toll Revenue Scenario 4</b>
Estimated Weekday Total Traffic	169,581	169,581	169,581	169,581
Estimated Truck Volumes	17,853	17,853	17,853	17,853
Estimated Auto Diversion Rate	20%	25%	30%	35%
Estimated Truck Diversion Rate	25%	30%	35%	40%
Annualization Factor	320	320	320	320
Toll Rate - Auto	\$3.00	\$4.00	\$5.00	\$6.00
Toll Rate - Trucks	\$4.00	\$5.00	\$6.00	\$7.00
O&M Cost	\$33,000,000	\$33,000,000	\$33,000,000	\$33,000,000
Debt Coverage Level	1.5	1.5	1.5	1.5
<b>Estimated Annual Tunnel Traffic</b>				
Annualized Auto Traffic	38,842,240	36,414,600	33,986,960	31,559,320
Annualized Truck Traffic	4,284,720	3,999,072	3,713,424	3,427,776
<b>Estimated Tunnel Revenues</b>				
Annual Auto Revenue	\$116,526,720	\$145,658,400	\$169,934,800	\$189,355,920
Annual Truck Revenue	\$17,138,880	\$19,995,360	\$22,280,544	\$23,994,432
<b>Total Annual Revenue</b>	<b>\$133,665,600</b>	<b>\$165,653,760</b>	<b>\$192,215,344</b>	<b>\$213,350,352</b>
<b>Estimated O&amp;M Costs</b>				
Annual O&M Cost Estimate	\$33,000,000	\$33,000,000	\$33,000,000	\$33,000,000
<b>Estimated Net Revenue</b>				
Annual Net Revenue Estimate	\$100,665,600	\$132,653,760	\$159,215,344	\$180,350,352
Available for Bonding (Coverage Rate 1.5)	\$67,110,400	\$88,435,840	\$106,143,563	\$120,233,568
Issue Bonds (13 times Available for Bonding)	\$872,435,200	\$1,149,665,920	\$1,379,866,315	\$1,563,036,384
Percent of Total Project (\$3 billion)	29.08%	38.32%	46.00%	52.10%
Additional Cost to Project (Interest on Bonds)	\$411,789,479	\$737,670,488	\$1,019,444,979	\$1,166,440,977

Source: Sharon Greene and Associates, May 2006.

Also Tables 10-5 (autos only use tunnel) and 10-6 (autos and trucks use tunnel) provide additional estimates of the potential percent of the total construction costs from toll revenue bond based on variations in the toll rate and the diversion rate.

**Table 10-5:**  
**Estimated Percent of Total Construction Cost Paid by Toll Revenue Bonds – Autos Only**

<b>Diversion Rate</b>	<b>\$2 Toll</b>	<b>\$3Toll</b>	<b>\$4 Toll</b>	<b>\$5Toll</b>	<b>\$6 Toll</b>	<b>\$7 Toll</b>
15%	21%	35%	49%	64%	78%	93%
20%	19%	33%	46%	60%	73%	87%
25%	17%	30%	43%	55%	68%	81%
30%	16%	27%	39%	51%	63%	75%
35%	14%	25%	36%	47%	58%	69%
40%	12%	22%	33%	43%	53%	63%
=Maximum potential share of project funding considered reasonable						

Source: Sharon Greene and Associates, May 2006.

**Table 10-4:**  
**Estimated Percent of Total Construction Cost Paid by Toll Revenue Bonds – Autos and Trucks**

<b>Diversion Rate *</b>	<b>\$2 Auto / \$3 Truck</b>	<b>\$3 Auto / \$4 Truck</b>	<b>\$4 Auto/ \$5 Truck</b>	<b>\$5 Auto / \$6 Truck</b>	<b>\$6 Auto / \$7 Truck</b>	<b>\$7 Auto/ \$8 Truck</b>
15%A / 25%T	18%	31%	44%	58%	71%	84%
20%A / 30%T	16%	29%	41%	54%	66%	78%
25%A / 35%T	15%	26%	38%	50%	62%	73%
30%A / 40%T	13%	24%	35%	46%	56%	67%
35%A / 45%T	11%	21%	31%	42%	52%	62%
40%A / 50%T	10%	19%	28%	38%	47%	56%
* %of Autos / % of Trucks Diverted						
=Maximum potential share of project funding considered reasonable						

Source: Sharon Greene and Associates, May 2006.

***Policy Considerations***

In addition to the toll revenue generation and level of bonding potential associated with tolling, there are several risk factors that must be considered with respect to inclusion of tolling in the financial strategy for the project including model input risk, event/political risk, ramp-up risk, and construction risk. The Financial Report has described examples of recent toll projects and highlighted the types of risk experienced.

Based on those examples, it is anticipated that future projects will be required to provide more detailed analysis and justification of assumptions for the cost and revenue estimates that are submitted as part of their request for bond funding.

Bond funding will likely not be available until the construction is nearly completed or completed. Based on the project examples above, the bond market is much less likely to finance projects until the detailed construction costs and revenue estimates are available. This would include items like the final concrete and steel costs since these construction components costs can fluctuate greatly and there is no futures market for either component. Additionally, as a

financial strategy, it is more advantageous to wait until the toll revenue will be generated so the agency will not have to capitalize interest on bonds while waiting for revenue service to start.

### ***Revenue Potential***

With consideration to the assumptions and risk factors, tolling could potentially play a role in the funding and financing of a project.

- Total annual net revenue generated from tolls (total annual revenue *minus* estimated annual O&M costs) was estimated to range from \$100 million to \$200 million. As shown in the tables above, the level of annual revenue generated would be dependent on a number of factors – including the magnitude of the toll charged and the extent to which potential users diverted to alternate free routes.
- As the toll charge increased, the diversion rate to alternate free routes was also assumed to increase. Trucks were assumed to have a higher elasticity with respect to toll rates, with higher diversion rates than other vehicular traffic. Thus, higher tolls were assumed to result in fewer trips being made on the facility. As a key goal of the project is to provide regional and local transportation benefits, it would be necessary to resolve the conflicting objectives of maximizing toll revenue generation and maximizing facility usage.
- As a cursory estimate of the share of construction cost that could be funded through tolls, this analysis indicated that tolling could potentially fund up to 50 percent of the construction cost. There are strong caveats to this statement, on both the cost side and the revenue side, including the lack of a real project cost estimate or phasing plan; and exclusion of key cost elements including real and inflationary impacts on construction costs over time, financing costs, and transaction costs; and the cursory estimation of toll revenues in the absence of real projections.
- As demonstrated by the examples, there is a high level of risk associated with financing start-up toll projects. To offset some of the risks, high coverage ratios, double-barreled revenue commitments, and bond insurance would likely be required.

### **10.3 Screening of Sources**

The following provides a brief description of several programs that were identified as potential funding sources for the Route 710 Tunnel project, however, at this time they were not carried forward into the financial strategies analysis.

- **Federal Sources:**
  - Transportation, Community, and System Preservation Program (TCSP) is intended to address the relationships among transportation, community, and system preservation plans and practices and identify private sector-based initiatives to improve those relationships. Due to this programs limited total funding level and limited funding levels available for individual projects, it was not included in the financial strategies analysis.

- Transportation Enhancement Activities program is intended for bicycle, transit, landscaping, public art, or historic projects linked to transportation. On a per project basis, limited funding (less than \$5 million) is available and therefore was not included in the financial strategies analysis.
- FTA Section 5307 Urbanized Area Formula Funds Program provides transit capital and operating assistance to urbanized areas. For the Route 710 Tunnel, no or limited funding is expected to be available for transit-related project components.
- FTA Section 5309 Discretionary Funds Program provides capital assistance for new or extensions to fixed guideways, fixed guideway modernization, and bus/bus related facilities. If a transit guideway is included in the design of the Route 710 Tunnel this program could potentially be pursued. However, at this stage of project development the Section 5309 program was not included in the financial strategies analysis.
- Department of Defense (DOD) Military Construction Funds are Congressional earmarks in the annual Military Construction Appropriations bill and/or in the DOD's Future Years Defense Program for safety, health, environmental, and military utility. This program could be re-evaluated in the future due to the improved connection between the Ports and inland logistical bases provided by the Route 710 Tunnel.
- **Regional/Local Sources:** Transportation impact fees and tax increment financing programs have been successfully used around the country on major public projects. However, since this is an early phase of project development it is not appropriate to include these two sources as part of this Financial Strategies Report. However, in the future if the project moves forward and additional engineering and cost details evolve, these approaches could be re-evaluated for potential inclusion as a component of the Financial Plan.

## 10.4 Financial Scenarios

Seven preliminary financial scenarios were developed based on the funding sources identified in Section 10.2. Each financial scenario places different levels of emphasis on federal, state, regional/local and toll revenue bond funding contributions. Three scenarios assumed the project would not include toll revenue bond proceeds as a funding source and four scenarios assumed the project would include toll revenue bond proceeds. Table 10-7 summarizes the ranges of potential federal, state, regional/local and toll revenue bond funding comprising the seven scenarios. The target percentages and equivalent funding contributions shown in the following assume a working construction cost estimate of \$3.0 billion (2006 dollars). However, depending on which construction scenario is chosen and when construction begins, the \$3 billion (2006 dollar) order of magnitude construction cost estimate is projected to be in the range of \$4.3 to \$5.5 billion year of expenditure dollars. At this stage of project development, it is assumed that revenue from the sources identified in the following sections would grow at the same rate of inflation as the construction costs. As a result the target percent shares from the different funding sources would be maintained as shown in the figures below. Finally, for the purpose of this analysis, the cost curves for the seven financial scenarios reflect the 11.5 year construction schedule of Construction Scenario 2 described in the study's Financial Strategy Report.

**Table 10-5:**  
**Levels of Federal, State, Regional/Local and Toll Revenue**  
**Funding Comprising the Financial Scenarios**  
**(2006 dollars)**

<b>Funding Sources</b>	<b>Percent Range</b>	<b>Funding Range</b>
Federal Contribution	0 Percent to 48 Percent	\$0.0 to \$1.4 billion
State Contribution	12 Percent to 20 Percent	\$360 million to \$600 million
Regional/Local Contribution	28 Percent to 58 Percent	\$840 million to \$1.74 billion
Toll Revenue <sup>1</sup>	0 Percent to 50 Percent	\$0 million to \$1.5 billion

Note: <sup>1</sup> For this analysis it was assumed that the toll rates and diversion percentages would support the level of bonding assumed in the four scenarios that include toll revenue bond proceeds as a source.

Source: Sharon Greene & Associates, May 2006.

Table 10-8 and Figure 10-1 summarize the levels of federal, state, and regional/local funding comprising the three financial scenarios that do not include tolling.

**Table 10-6:**

10-133

**Preliminary Route 710 Tunnel Financial Scenarios - No Toll Revenue Bonds  
(2006 dollars)**

CONTRIBUTOR	SCENARIOS WITHOUT TOLLING					
	SCENARIO 1: (48-12-40-0)		SCENARIO 2: (30-20-50-0)		SCENARIO 3: (30-12-58-0)	
	% Share	\$ Share	% Share	\$ Share	% Share	\$ Share
<b>FEDERAL (range: 30%-48%)</b> <i>FHWA Core Programs</i> <i>FHWA Earmarks</i> <i>TIFIA</i> <i>Tolling Programs</i>	48%	\$1,440,000,000	30%	\$900,000,000	30%	\$900,000,000
<b>STATE (range: 12%-20%)</b> <i>STIP:IRTP</i> <i>STIP-GARVEE Bonds</i> <i>Future State Bond Program</i>	12%	\$360,000,000	20%	\$600,000,000	12%	\$360,000,000
<b>REGIONAL/LOCAL (range: 40% - 58%)</b> <i>STIP: RTIP</i> <i>STIP: GARVEE Bonds</i> <i>Proposition C Funding</i> <i>Future County Sales Tax</i>	40%	\$1,200,000,000	50%	\$1,500,000,000	58%	\$1,740,000,000
<b>TOTAL</b>	<b>100%</b>	<b>\$3,000,000,000</b>	<b>100%</b>	<b>\$3,000,000,000</b>	<b>100%</b>	<b>\$3,000,000,000</b>

Source: Sharon Greene & Associates, May, 2006.

**Figure 10-1:  
Composition of Proposed Revenues – No Toll Revenue Bond Scenarios**

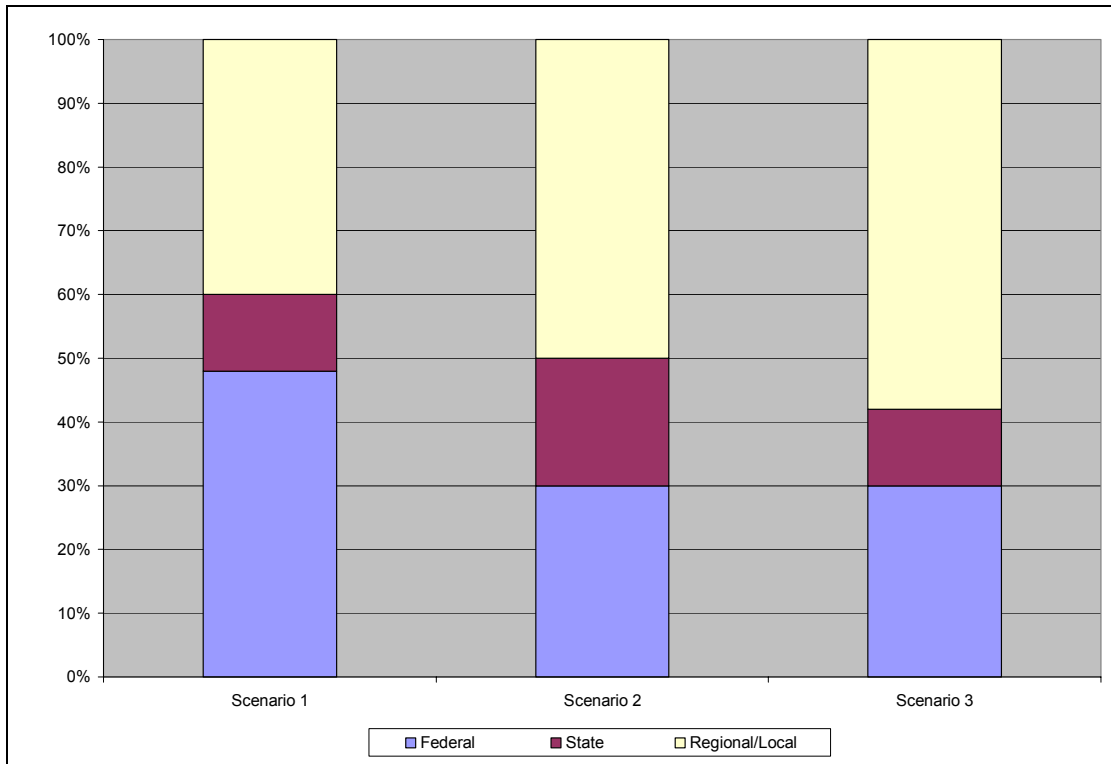

Source: Sharon Greene & Associates, May 2006

Table 10-9 and Figure 10-2 summarize the levels of federal, state, regional/local, and toll revenue bond funding comprising the four financial scenarios that do include tolling. The

seven scenarios are described in more detail following the tables.

**Figure 10-2:  
Composition of Proposed Revenues – Toll Revenue Bond Scenarios**

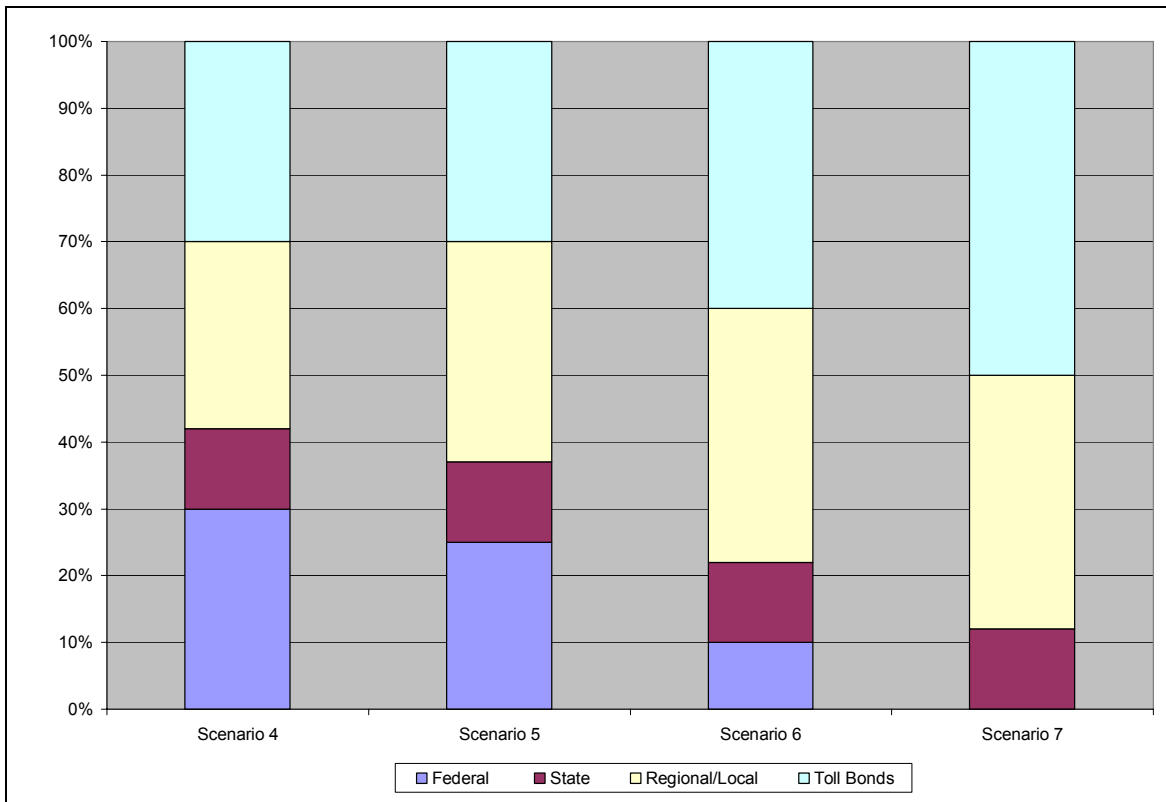

Source: Sharon Greene & Associates, May 2006



**Table 10-7:  
Preliminary Route 710 Tunnel Financial Scenarios – Includes Toll Revenue Bonds  
(2006 dollars)**

	SCENARIOS WITH TOLLING							
	SCENARIO 4: (30-12-28-30)		SCENARIO 5: (25-12-33-30)		SCENARIO 6: (10-12-38-40)		SCENARIO 7: (0-12-38-50)	
CONTRIBUTOR	% Share	\$ Share	% Share	\$ Share	% Share	\$ Share	% Share	\$ Share
<b>FEDERAL (range: 0% - 30%)</b>	<b>30%</b>	<b>\$900,000,000</b>	<b>25%</b>	<b>\$750,000,000</b>	<b>10%</b>	<b>\$300,000,000</b>	<b>0%</b>	<b>\$0</b>
<i>FHWA Core Programs FHWA Earmarks TIFIA Tolling Programs</i>								
<b>STATE ( 12% all scenarios)</b>	<b>12%</b>	<b>\$360,000,000</b>	<b>12%</b>	<b>\$360,000,000</b>	<b>12%</b>	<b>\$360,000,000</b>	<b>12%</b>	<b>\$360,000,000</b>
<i>STIP:IRTP STIP-GARVEE Bonds Future State Bond Program</i>								
<b>REGIONAL/LOCAL (range: 28% - 38%)</b>	<b>28%</b>	<b>\$840,000,000</b>	<b>33%</b>	<b>\$990,000,000</b>	<b>38%</b>	<b>\$1,140,000,000</b>	<b>38%</b>	<b>\$1,140,000,000</b>
<i>STIP: RTIP STIP: GARVEE Bonds Proposition C Funding Future County Sales Tax</i>								
<b>TOLL BONDS (range: 30% - 50%)</b>	<b>30%</b>	<b>\$900,000,000</b>	<b>30%</b>	<b>\$900,000,000</b>	<b>40%</b>	<b>\$1,200,000,000</b>	<b>50%</b>	<b>\$1,500,000,000</b>
<i>Bonds</i>								
<b>TOTAL</b>	<b>100%</b>	<b>\$3,000,000,000</b>	<b>100%</b>	<b>\$3,000,000,000</b>	<b>100%</b>	<b>\$3,000,000,000</b>	<b>100%</b>	<b>\$3,000,000,000</b>

Source: Sharon Greene & Associates, May, 2006.

## 10.5 Financial Scenarios Without Tolling

Based on discussions with LACMTA staff, three financial scenarios were developed that do not include funding from toll revenue bonds. As a starting point, the following were assumed to be the maximum feasible levels of participation from the funding sources:

- Federal: not to exceed 30 percent of total project funding from earmarked federal sources due to the competition with other national and regionally significant projects in the region and the impact of earmarked funding on MTA's STIP-RIP share;
- State: up to 12 percent of total project funding based on maximizing MTA's potential share of the Urban ITIP program using GARVEE bonds; and
- Regional/Local: up to 40 percent of total project funding based on the need to fund other regional and local projects in the RTIP.

In order to develop financial scenarios that would achieve the level of funding required, one or more of the feasible levels of participation would be exceeded. For example, if the state and regional/local funding shares remain within the feasible limit, then the federal funding share would exceed its maximum feasible level. At this point of project development, of the three financial scenarios without tolling, Scenarios 2 and 3 would be considered feasible only if new funding sources were implemented at the state and regional levels.

### 10.5.1 Scenario 1

#### *Description*

Financial Scenario 1 assumes the largest federal share, with 48 percent of project funding from earmarked federal sources. The remaining 52 percent in matching funds is assumed to be derived from a state match of 12 percent, and a regional/local match of 40 percent.

#### *Policy Considerations*

This scenario meets the state and regional/local feasible funding limits but exceeds the range considered reasonable for federal earmarked funding by 18 percent. Due to the competition for federal funds from other projects and the impact on MTA's county STIP share, it is unlikely that the Route 710 Tunnel would be able to achieve this level of federal funding.

#### *Revenue Potential*

Figure 10-3 illustrates the annual levels of funding that would be required over the Route 710 Tunnel's twelve year planning, design and construction period assumed for this analysis.

**Figure 10-3**  
**Scenario 1: (48% Federal, 12% State, 40% Regional/Local)**  
**Capital Funding Required, by Year (2006 Dollars)**

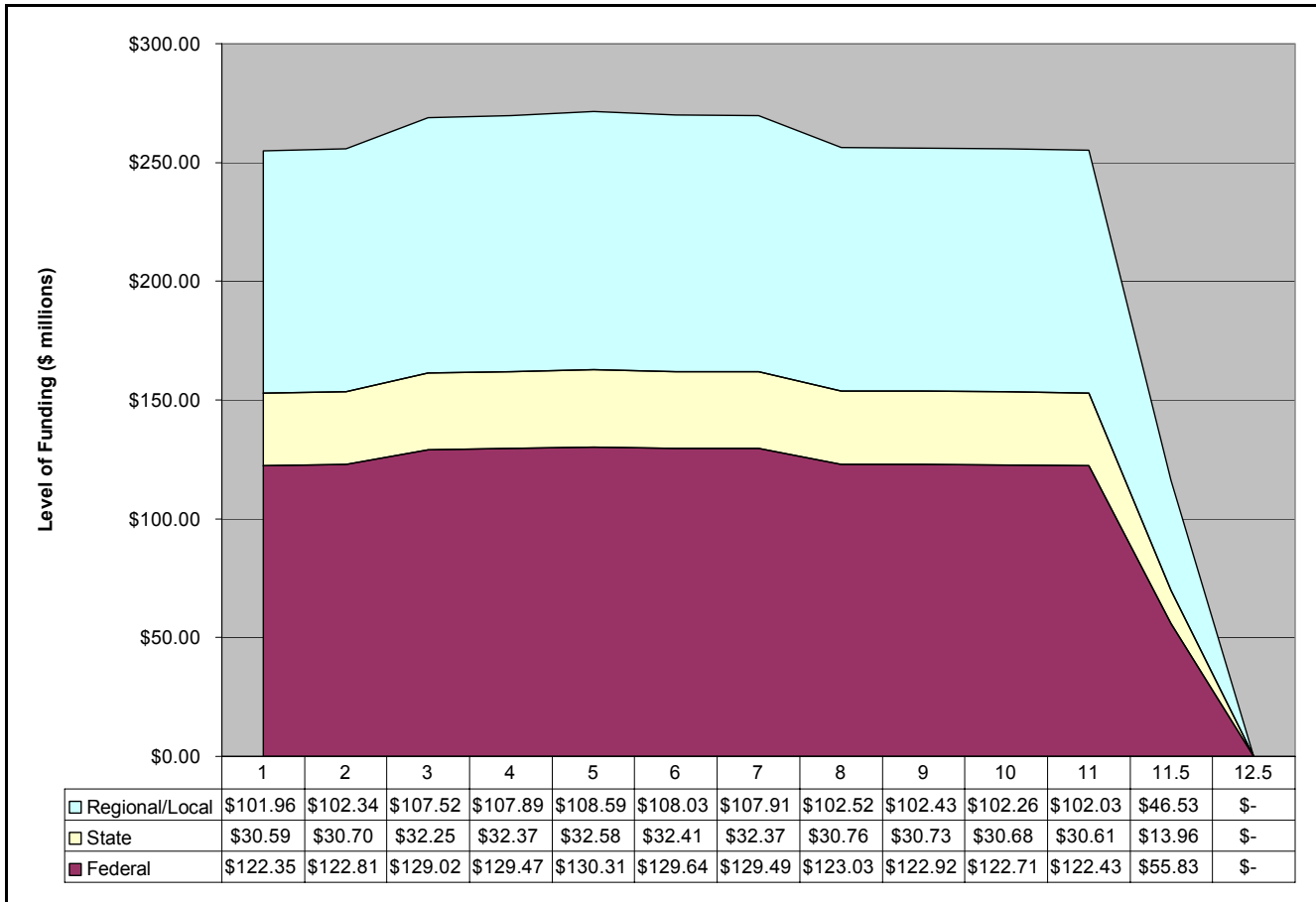

Source: Sharon Greene & Associates, May 2006.

### 10.5.2 Scenario 2

#### *Description*

Financial Scenario 2 assumes a federal match of 30 percent, a state match of 20 percent and a regional/local match of 50 percent.

#### *Policy Considerations*

This scenario is within the feasible federal funding limit but exceeds the state limit by 8 percent and the regional/local limit by 10 percent. However, this scenario could be considered a feasible option if new funding sources became available at the state and the region/local level.

#### *Revenue Potential*

Figure 10-4 illustrates the annual levels of funding that would be required over the Route 710 Tunnel’s twelve year planning, design and construction period assumed for this analysis.

**Figure 10-4**  
**Scenario 2: (30% Federal, 20% State, 50% Regional/Local)**  
**Capital Funding Required, by Year (2006 Dollars)**

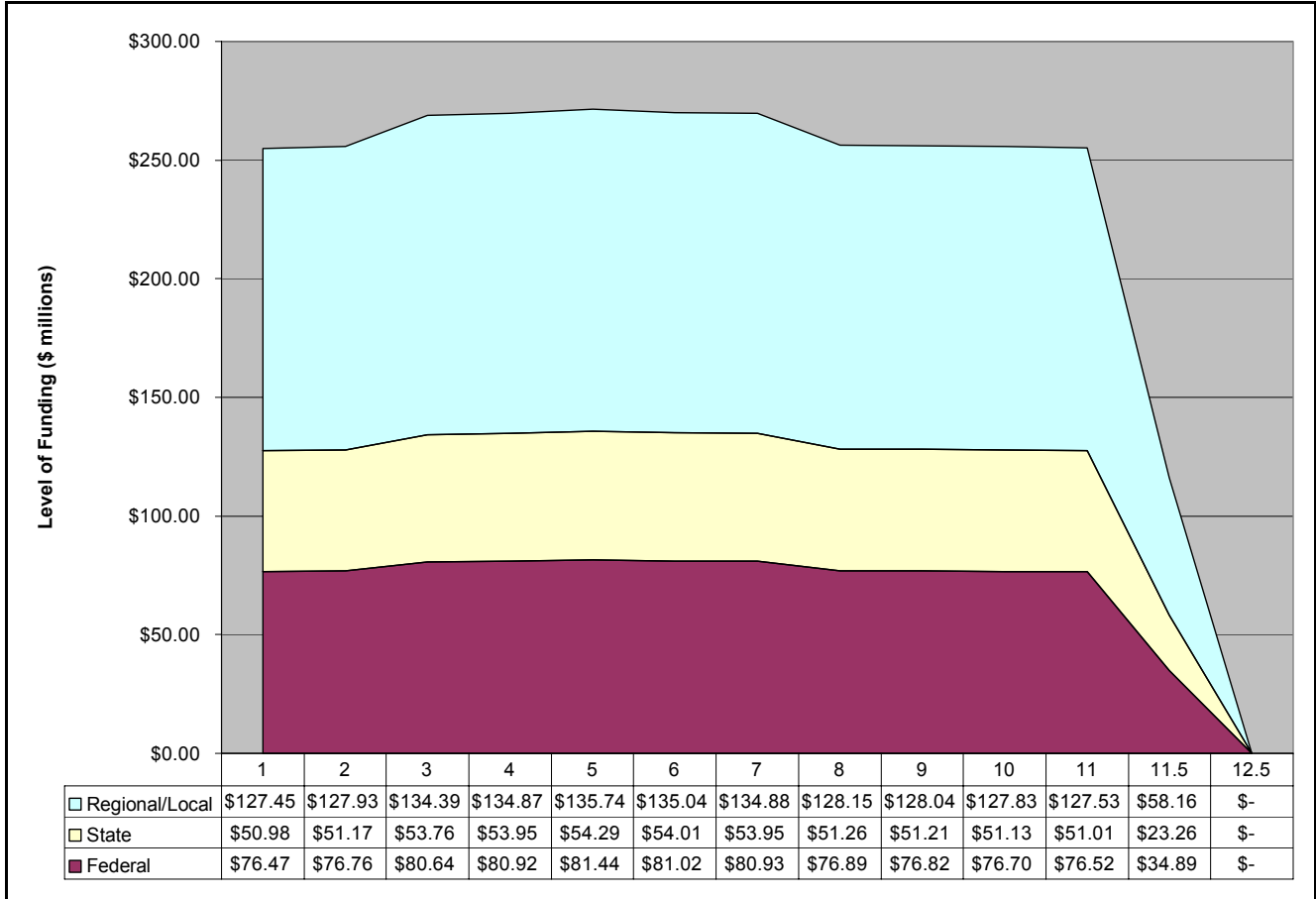

Source: Sharon Greene & Associates, May 2006.

### 10.5.3 Scenario 3

#### *Description*

Financial Scenario 3 assumes a federal match of 30 percent, a state match of 12 percent and a regional/local match of 58 percent.

#### *Policy Considerations*

This scenario meets the federal and state feasible funding limits but exceeds the regional/local limit by 18 percent. However, this scenario could be considered a feasible option if a new funding source became available at the region/local level.

*Revenue Potential*

Figure 10-5 illustrates the annual levels of funding that would be required over the Route 710 Tunnel’s twelve year planning, design and construction period assumed for this analysis.

**Figure 10-5**  
**Scenario 3: (30% Federal, 12% State, 58% Regional/Local)**  
**Capital Funding Required, by Year (2006 Dollars)**

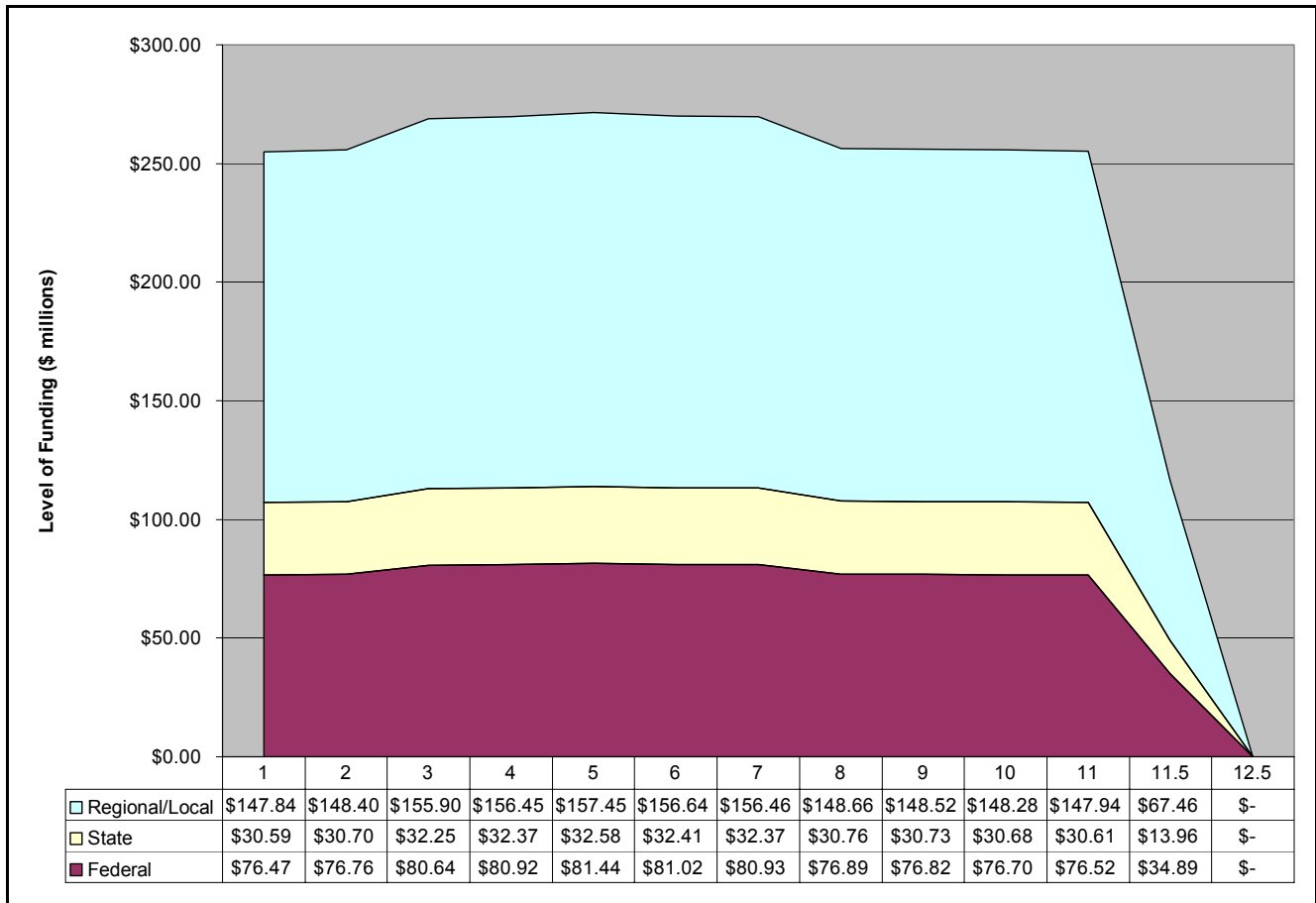

Source: Sharon Greene & Associates, May 2006.

**10.6 Scenarios with Tolling**

Based on discussions with LACMTA staff, four scenarios were developed that incorporated user fees (toll revenue bond proceeds) as a fourth funding source. The percent of the total construction cost from toll revenue bond proceeds ranged from 30 to 50 percent. This range allowed for a variety of ways to keep federal, state and regional/local participation within the feasible levels (30 percent, 12 percent, and 40 percent respectively).

**10.6.1 Scenario 4**

*Description*

Financial Scenario 4 assumes a federal participation of 30 percent, a State match of 12 percent, a Regional/Local match of 28 percent, and toll revenue bond proceeds of 30 percent. Funding from the toll revenue bonds would be used during the last 4.5 years of the project construction period.

*Policy Considerations*

Of the four financial scenarios with toll revenue bonds, the objective of this scenario is to maximize federal funding, while minimizing reliance on tolling and on regional/local funding.

*Revenue Potential*

Figure 10-6 illustrates the annual levels of funding that would be required over the Route 710 Tunnel’s twelve year planning, design and construction period assumed for this analysis.

**Figure 10-6**  
**Scenario 4: (30% Federal, 12% State, 28% Regional/Local, 30% Toll Revenue Bonds)**  
**Capital Funding Required, by Year (2006 Dollars)**

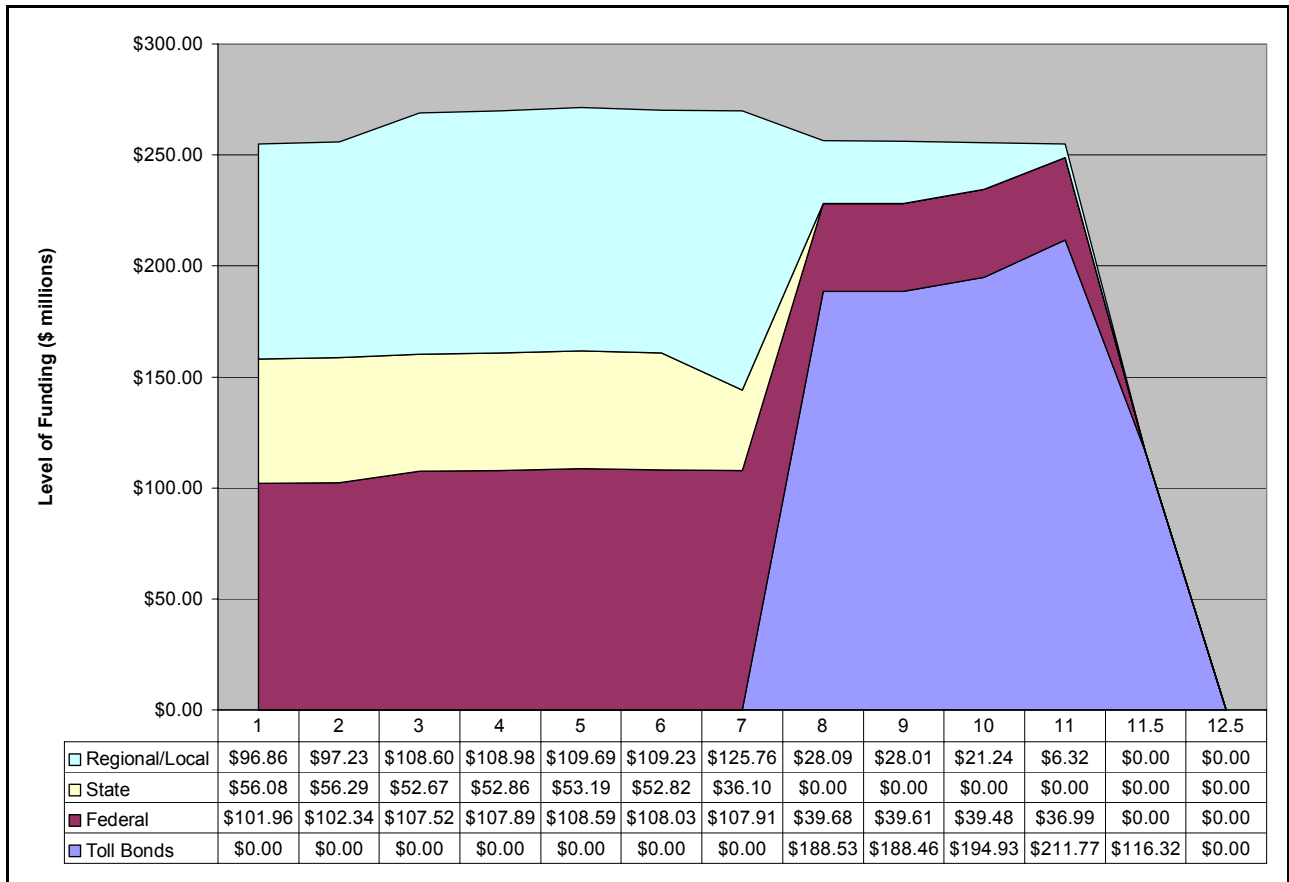

Source: Sharon Greene & Associates, May 2006.

### **10.6.2 Scenario 5**

#### *Description*

Financial Scenario 5 would reduce federal participation to 25 percent, maintain State participation at 12 percent, slightly increase the Regional/Local participation to 33 percent, and maintain toll revenue bond proceeds at 30 percent. Funding from the toll revenue bonds would be used during the last 4.5 years of the project construction period.

#### *Policy Considerations*

The objective of this scenario is to illustrate the impact of a reduction in the level of federal funding participation from 30 percent to 25 percent, and the associated increase in the level of regional/local funding. The increased regional/local level (33 percent) is within the maximum feasible limit (40 percent) for this funding source.

#### *Revenue Potential*

Figure 10-7 illustrates the annual levels of funding that would be required over the Route 710 Tunnel's twelve year planning, design and construction period assumed for this analysis.

**Figure 10-7**  
**Scenario 5: (25% Federal, 12% State, 33% Regional/Local, 30% Toll Revenue Bonds)**  
**Capital Funding Required, by Year (2006 Dollars)**

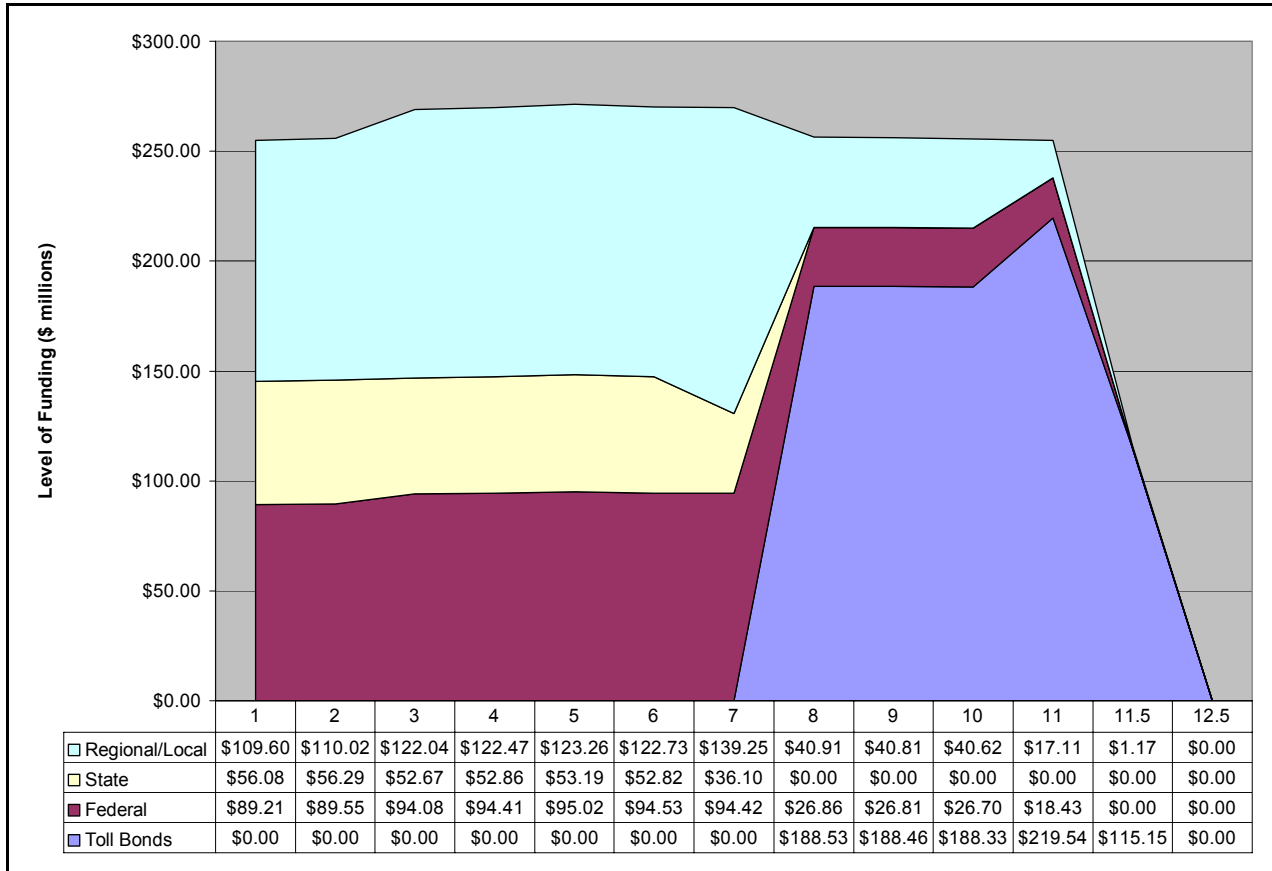

Source: Sharon Greene & Associates, May 2006.

### 10.6.3 Scenario 6

#### *Description*

Financial Scenario 6 would further reduce funding from federal earmarked sources to 10 percent, maintain State participation at 12 percent, increase the Regional/Local match to 38 percent, and increase toll revenue bond participation to 40 percent. Funding from the toll revenue bond proceeds would be used during the last 5 years of the project construction period.

#### *Policy Considerations*

This scenario further reduces the level of federal funding participation and increases the level of regional/local funding and toll revenue bond proceeds by the same amount. The increased regional/local level (38 percent) is within the maximum feasible limit (40 percent) for this funding source.



*Revenue Potential*

Figure 10-8 illustrates the annual levels of funding that would be required over the Route 710 Tunnel’s twelve year planning, design and construction period assumed for this analysis.

**Figure 10-8**  
**Scenario 6: (10% Federal, 12% State, 38% Regional/Local, 40% Toll Revenue Bonds)**  
**Capital Funding Required, by Year (2006 Dollars)**

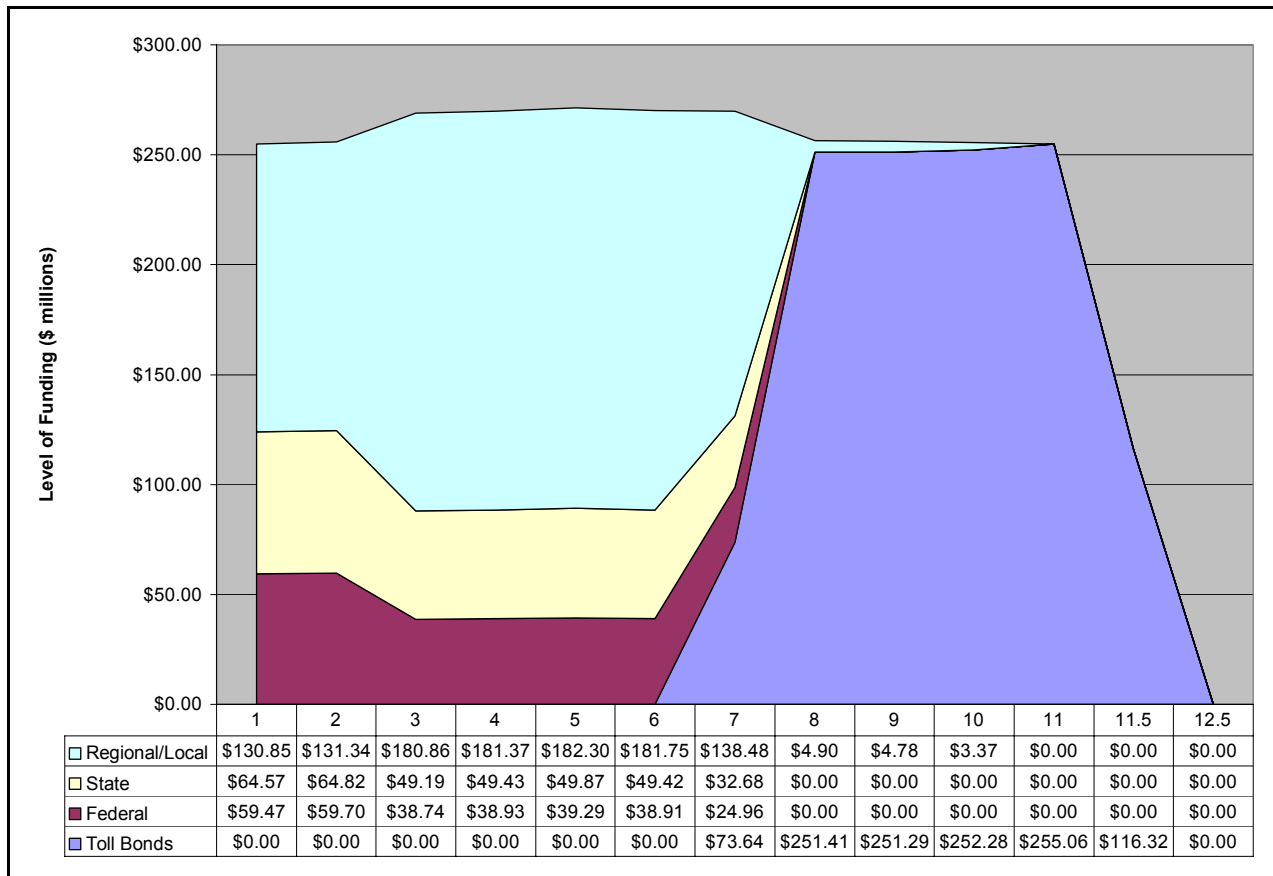

Source: Sharon Greene & Associates, May 2006.

**10.6.4 Scenario 7**

*Description*

Financial Scenario 7 assumes no funding from federal earmarked sources, maintains State participation at 12 percent, maintains the Regional/Local match at 38 percent, and increases toll revenue bond participation to 50 percent. Funding from the toll revenue bond proceeds would be used during the last 6 years of the project construction period.

*Policy Considerations*

To compensate for the assumption of no federal participation in the project, the level of construction costs covered by toll revenue bonds would be increased to 50 percent. Based on the

information available at this time, this level of funding from toll revenue bond proceeds is considered the maximum feasible level of participation for this funding source.

*Revenue Potential*

Figure 10-9 illustrates the annual levels of funding that would be required over the Route 710 Tunnel’s twelve year planning, design and construction period assumed for this analysis.

**Figure 10-9**  
**Scenario 7: (0% Federal, 12% State, 38% Regional/Local, 50% Toll Revenue Bonds)**  
**Capital Funding Required, by Year (2006 Dollars)**

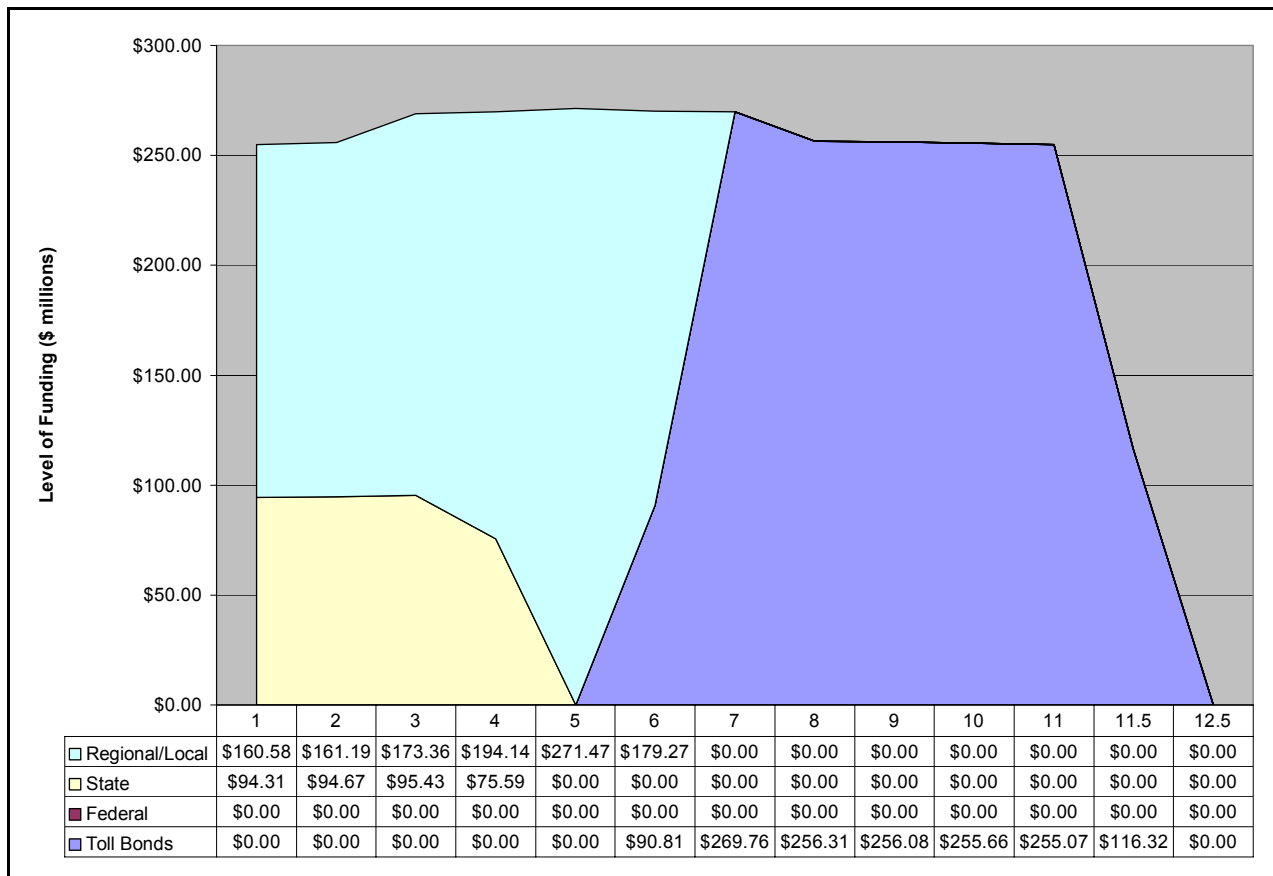

Source: Sharon Greene & Associates, May 2006.

**10.7 Next Steps**

The funding sources and financial scenarios considered in this report provide a starting point for development of a financial plan for the Project. Implementation of the project will require a significant investment from a variety of federal, state, regional and local funding programs. At this point of project development and as described in this report, there are a number of funding programs and several financing scenarios available to consider as the project moves forward. However, it will be important for LACMTA, Caltrans, and SCAG to continue to work with local,

state and federal officials to demonstrate the significance of the project and to make the case in order to be competitive for future funding.

Additionally, as the project proceeds through the state and federal environmental and project implementation processes, completion of a comprehensive financial plan, that includes construction costs and project costs associated with the environmental documentation, preliminary and final design, construction management, insurance, and agencies/force account oversight and staff, will be required component.

Finally, consideration should also be given to potential institutional arrangements that could facilitate implementation of the project. Such institutional arrangements could include formation of a special-purpose Joint Powers Authority (JPA) to design, build, finance, and potentially operate and maintain the Route 710 Tunnel. An overview of key issues associated with the formation of Joint Powers Authority has been discussed in the Study's Financial Analysis Report.

This Page Intentionally Left Blank

## **11.0 Feasibility Assessment Conclusions**

### **11.1 Introduction**

Over the past year, the Metropolitan transportation Authority (MTA) study team, in coordination with its consultant, has been conducting a feasibility assessment of a bored or mined tunnel to complete the Route 710 Gap. This assessment has been performed in close coordination with the technical staff from the state, regional and local agencies affected by the tunnel concept. Representatives from these affected agencies formed the Route 710 Tunnel technical feasibility assessment's Working Group and provided technical input throughout the study.

The purpose of the Route 710 Tunnel Technical Feasibility Assessment was to determine whether a bored or mined tunnel alternative is viable and practical; and to determine whether additional actions or studies should be undertaken to advance this concept further. The technical feasibility of the tunnel concept was addressed from the Physical, Environmental and Financial perspectives.

The conclusions and the findings of this feasibility study are summarized below.

### **11.2 Physical Feasibility**

The primary purpose of the tunnel feasibility assessment from the physical perspective is to assess the viability and suitability of implementing a tunnel through the Route 710 Gap based on current engineering and construction practices. This assessment was performed, in consideration, with the suitability of the geotechnical, geologic, hydrological, seismic conditions and the ability of the tunnel concepts to satisfy traffic demand, highway and geometric standards, ventilation requirements, and other safety criteria.

Although this tunnel feasibility assessment is broad in nature, based upon the technical evaluations and analyses conducted for this study, it appears that a tunnel alternative is a viable concept to close the Route 710 Gap from the physical perspective. However, more comprehensive and detailed evaluations will be necessary to develop strategies and methods to effectively address specific elements related to overall feasibility of the tunnel concept.

The following is a brief summary of the physical elements and considerations that led to the general conclusion that the tunnel concept is feasible and valid from the physical aspects.

#### **11.2.1 Traffic Considerations**

From the traffic modeling and analysis effort, alternative tunnel scenarios were considered including options that provided three or four lanes of traffic in each direction and scenarios with and without the inclusion of a fully directional interchange at Huntington Drive. This feasibility assessment addressed the potential implication of adding an interchange connecting traffic along Huntington Drive and the tunnel. For this interchange, the analysis evaluated the provision of a

full service interchange with four on- and off-ramps serving both northbound and southbound tunnel directions. Additionally, the analysis considered traffic with and without large trucks permitted to use the tunnel. The traffic forecasting and analysis considered alternative operational tunnel scenarios with the following options: a) three and four lane per directions; b) mixed use traffic (all vehicular types) and restricted traffic excluding truck use in the tunnel; and c) with and without an interchange at Huntington Drive.

For the detailed traffic results, refer to Chapter 5 entitled Traffic Modeling/Traffic Analysis. The traffic analysis concluded that the tunnel would require four lanes in each direction to adequately serve the anticipated future 2030 traffic demand. The tunnel scenario that included four lanes of traffic in each direction without the Huntington Drive interchange proved to have sufficient capacity to maintain an acceptable Level of Service (LOS) “E” in the forecast year of 2030. For highways, a typical measure of its operating characteristics or performance along a segment of the facility is Level of Service. LOS is a qualitative description of the freeway’s ability to accommodate peak period traffic in terms of the maneuverability and delay. The LOS ratings range from LOS “A” (free-flow conditions) to LOS “F” (considerable to severe congestion or “stop-and-go” conditions). LOS “E” has been established as the minimum acceptable threshold for facilities in the Los Angeles regional area.

Tunnel scenarios with three lanes per direction with or without the Huntington Drive interchange were determined to yield an unacceptable level of service and motorists will experience severely congested conditions during the peak periods, and so the three lane tunnel options were discarded due to their inability to adequately meet the future traffic volumes. Additionally the four-lane tunnel scenario with the Huntington Drive interchange would result in additional constraints since a segment of the northbound tunnel, between the southern portal and the interchange, would still experience LOS “F” operations during the afternoon peak period.

Although the inclusion of an interchange should remain an option in future study, this technical feasibility assessment focused its evaluation of tunnel concepts on the options that provided four lanes of traffic in each direction without the interchange at Huntington Drive. As discussed in Chapter 6, “Tunnel Configuration and Alignment”, nine representative tunnel cross-sections were considered and evaluated as part of this assessment. Each of these alternatives provided four lanes of traffic in each direction in either two or three tunnels depending on the tunnel configuration. All tunnel concepts that provided four lanes of traffic in both directions without the interchange were determined to provide an adequate capacity to meet the anticipated traffic demand while maintaining traffic operations at LOS “E” or better.

The comparison of the scenarios with and without truck traffic concluded that the tunnel traffic operations would only be marginally improved by imposing the restriction on trucks using the Route 710 tunnel. Although tunnel traffic operational performance improved comparing the “Truck-restricted” scenarios compared to the mixed vehicular use scenarios, the improvement did result in a significant improvement in performance. In no comparisons did the anticipated traffic performance improve to the next better level of service classification by restricting truck

use through the tunnel. Although the restriction on truck use appears to have some operational benefit and may have some environmental benefit, it should be noted that the restriction may preclude potential funding sources available for “Goods Movement” or other programs. The inclusion of truck traffic would affect tunnel configuration, cost, financial, environmental, and operational

The effect of the Route 710 tunnel alternatives on the adjacent freeway and arterial network was evaluated and determined that, generally, the completion of the Route 710 gap has a neutral or beneficial traffic impact on most adjacent freeways and arterials in proximity to the study area. Currently in the absence of a continuous Route 710 freeway through the El Sereno area of Los Angeles, Alhambra, South Pasadena and Pasadena, motorists use a variety of routes to get from one end of the gap to the other. Some of motorists use the adjacent freeway network or arterial streets to traverse the Gap. The analysis of the traffic model data comparing the tunnel scenarios to the Base Case condition without the closure of the gap revealed that a continuous Route 710 would cause a re-distribution of trips through study area.

On the freeway network in the vicinity of the study area, the tunnel alternatives resulted generally in a slight reduction or minimal change in traffic volumes during the peak periods as compared to the Base Case condition. However, the freeways, I-210 and I-10, on either end of the Route 710 tunnel will experience a growth in traffic volumes as compared to the Base Case. This increased traffic is directly attributable to trips that are attracted to the continuous link provided by the tunnel concept.

Along the I-210 Foothill freeway north of the US 134 Ventura Freeway, the peak hour traffic will increase between 1,900 to 2,500 vehicles per hour. This increased traffic volume is equivalent to approximately the hourly capacity of one freeway lane. Similarly Route 710 south of the I-10 San Bernardino Freeway, the traffic volumes of the tunnel concept is greater than the Base Case by roughly 600 to 2,000 vehicles during the peak hour. The likely impact of this added traffic is that it will degrade the level of service along these freeway segments.

The impact of the tunnel scenarios to the arterial street network is generally positive as compared to the Base Case. It is seen that traffic volumes for all tunnel scenarios generally decrease on all arterial streets segments at the southern end of the tunnel, including the Route 710 on-and off-ramps at Valley Boulevard, Valley Boulevard itself, Fremont Avenue, Atlantic Boulevard and Garfield Avenue. The decrease is also greater for the scenarios which include the Huntington Drive Interchange. This is to be expected, since the Huntington Drive interchange would provide an additional opportunity for vehicles to exit and enter the proposed tunnel.

Traffic volumes increase, however, on Huntington Drive west of Fremont Avenue for the scenarios that include the Huntington Drive Interchange, reflecting the longer trips using the tunnel without the interchange.

Generally, traffic volumes on arterial street segments north of Huntington Drive are projected to decrease with the gap-closure alternatives. In particular, significant reductions in projected traffic volumes are observed at Pasadena Avenue and St. John Avenue at California Boulevard. Reductions in traffic volumes are also observed on Fair Oaks Avenue and California Boulevard.

Based on the above discussion, from a traffic engineering perspective, it was determined that the four-lane tunnel concepts were feasible due to the following factors:

### **11.2.2 Geologic and Geotechnical Considerations**

The study tasks covered in Chapter 3 focused on the subsurface ground conditions based upon available geological data and supplemented with a minor geotechnical exploration program consisting of drilling three deep exploratory boreholes along the study corridor.

The study area for the potential tunnel alignments is quite large being over four miles long and two miles wide, and with the tunnel possibly as deep as 300 feet below the surface. The necessary data to enable full design would require much more extensive subsurface exploration program to augment the limited geotechnical information that is available at this time.

The currently available geotechnical information indicates that the subsurface conditions are favorable for tunneling. Soil conditions anticipated include predominantly soft sedimentary rocks – shales, sandstones, siltstones, and conglomerates and alluvial soils. These geologic and geotechnical conditions beneath the study area appear to have physical properties that are well suited for bored or mined tunneling.

Groundwater conditions are not well defined at this point but the recent field borings encountered groundwater at measured depths of 66 feet and 82 feet below the surface. Previous borings have encountered groundwater at depths shallower than 50 feet. The depth of the groundwater throughout the study area is not known and supplemental investigations are needed to fully characterize the conditions. However based on this limited information on the groundwater, the tunnel invert, or bottom of the interior floor of the tunnel, should be well below the groundwater.

The Los Angeles basin is a known area of active geologic deformation and seismic activity. Active seismic faults in the proximity of or crossing the potential corridor will influence the tunnel design for ground movement, shaking and displacement, during earthquakes. These conditions are not unusual and can be found throughout California, and numerous underground transportation facilities have been implemented in Los Angeles and San Francisco with similar seismic conditions. There are a number of identified faults that may influence the tunnel alignment; however, the most significant seismic fault to be considered is the Raymond Hill fault or as commonly referred to as the Raymond fault. Additional studies will be needed to better characterize the Raymond fault, but it represents conditions similar to the Metro Red Line subway tunnel that was driven through the Santa Monica-Hollywood fault system.



The study corridor would not pass through any known operating or abandoned oil or gas fields or identified methane zones. No known tar or oil seeps occur along tunnel study corridor. However, discontinuous seams of lignite coal have been found within the Topanga Sandstone and occurrences of methane and natural gas have been noted throughout the Los Angeles Basin. Therefore, it should be considered possible that the tunnel may encounter gassy conditions south of the Eagle Rock fault. North of the Eagle Rock fault, it is not anticipated that the tunnel will encounter gassy conditions. Should gassy subsurface conditions be encountered, a number of mitigation measures have been developed to overcome this on other underground projects.

In summary based upon the limited existing geologic and geotechnical information and the exploratory drilling program conducted for this feasibility assessment, the ground conditions are favorable for tunneling. From a geologic and geotechnical evaluation, the physical ground properties are considered to be suitable for tunneling in the study area. However, significant additional subsurface investigation is needed to more fully characterize the conditions.

### **11.2.3 Tunnel Technology**

To provide four-lanes of traffic in a single bored or mined tunnel will push the Route 710 tunnel concepts to the forefront of modern tunnel technology. However, there are a number of recent or active highway tunnel projects that lend credibility to physical feasibility of this concept. During research and discussion with industry experts, it is considered within the realm of reality that a Tunnel Boring Machine (TBM) may approach an outside diameter in the 55 to 56 feet range in the near future. This study considered four-lane bored tunnel alternatives with outside diameters ranging from 48 feet to 57 feet. Also considered were four-lane mined tunnel alternatives with outside diameters ranging from 60 feet to 72 feet.

In Chapter 2, Summary of Large Highway Tunnels - Domestic and International, there are a number of highway tunnels in urban settings that have attributes similar to the concepts for the Route 710 tunnel. The tunnels reviewed represent many of the world's most recent large diameter highway tunnels that feature state-of-the-art construction methods, equipment and operational concepts.

Three tunnels have particular relevance to the Route 710 tunnel concepts and these are the A-86 Motorway in Paris, France, the M30 Motorway in Madrid, Spain and the Mount Baker Ridge Tunnel in Seattle, Washington. The A-86 Motorway in Paris is located in an urban or suburban environment and includes a 6.2 mile long auto-only two-level (stacked roadway) tunnel. The tunnel will provide a total of six lanes of traffic (each travel lane is roughly 9.2 feet in width); three lanes of one-way traffic per level in this stacked configuration. The A-86 Motorway tunnel is being constructed using Tunnel Boring Machine (TBM) excavation method. The M30 Motorway in Madrid is at the center of a major urban renewal project and serves as the city's inner ring road. This project is currently under construction using the world's largest TBM. The South By Pass portion of this ring road includes a 2.2 mile segment of bored twin 50 feet diameter tunnels carrying three lanes of traffic per tunnel. The M30 Motorway shares many

characteristics with some of the Route 710 tunnel concepts. Finally, the Mt. Baker Ridge tunnel along I-90 in Seattle, Washington is an example of a tunnel that used innovative construction technique to construct a stacked, double deck roadway tunnel. This Seattle tunnel provides for one-way traffic through a five-lane double deck stacked tunnel cross-section (three lanes on the top level and two lanes below).

Each of the above described tunnels has selected specific physical attributes similar to the tunnel alternatives considered by this assessment. These physical attributes and features include tunnels in congested and environmentally sensitive urban settings, large diameter highway tunnels, double-deck stacked roadway configurations and large diameter TBM excavated tunnels (A-86 and M30 tunnels). In the determination of the physical feasibility of the Route 710 tunnel concepts these tunnels, along with other large highway tunnels, current and emerging tunnel technologies and construction methods were all considered. Some of the key factors evaluated as part of the potential applicable tunnel technologies are briefly described below. For a complete description of all factors considered by this assessment refer to Chapter 4 Tunnel Technologies.

#### **11.2.3.1 Horizontal Alignment**

The alignment of the tunnel alternatives will be controlled by traffic flow requirements, minimum highway curvature for the vehicle design speeds and geometric constraints for the connections to the existing freeways and existing right-of-way. For a tunnel of the size required, the smallest curve radius that a Tunnel Boring Machine (TBM) can negotiate would be in the range of 1,000 feet. This would be one of the design criteria used to layout the horizontal alignment and is well within the horizontal curvature of the example alignments considered in determining feasibility under this study.

Twin or multiple tunnels would need to maintain a minimum horizontal separation of approximately one tunnel diameter along the alignment to prevent overstressing of the central rock or soil pillar due to redistribution of ground loads around the tunnels as they are excavated.

#### **11.2.3.2 Vertical Alignment**

The vertical alignment of the tunnel would also be controlled by the approach elevations, highway standards for vertical curves, and the requirement to maintain sufficient cover over the crown of the tunnel. The vertical alignment establishes the tunnel cover and the hydrostatic pressure to be considered in the design, construction feasibility and planning. Other considerations would be possible ventilation shaft locations and any need for a potential interchange at Huntington Drive.

For this study, an effort was made to maximize the cover over the tunnel crown to reduce the potential for surface settlement and impacts on existing structures. A minimum cover of two tunnel diameters or 100 feet (assuming a 50 feet excavated diameter) has been selected for the feasibility analysis. At the tunnel entrances where the ramps approach the tunnel portals,

shallow cover will be necessary for the transition into the assumed nominal 100-foot depth of cover of the main alignment.

### **11.2.3.3 Tunnel Cross-Sectional Requirements**

In Chapter 6 Tunnel Configuration and Alignment, Figure 6.1 schematically illustrates cross sections assumed to accommodate four-lane tunnels in each direction, including allowance for shoulders and walkways – either to full highway standards or reduced standards. Depending on the final requirements for the cross section, the minimum excavated TBM diameter could vary from about 38 to 57 feet, and in the Sequentially Excavated Method (SEM) tunnels could span up to approximately 72. The larger TBM cross-sections would therefore need to exceed the size of the most recently constructed tunnels described in Chapter 2, but is comparable with the size of the M30 tunnel being constructed in Madrid, Spain, which has a 50 feet excavated diameter. Currently, the M30 tunnel is being constructed with the largest diameter tunnel boring machine used to date. Many tunneling industry authorities believe that a larger diameter TBM approaching the mid-50 feet will be feasible in the future. Consequently, the TBM excavated alternatives under consideration are within the range of current tunnel technology or emerging advancement in the field. However, the Route 710 cross-section that has a 57 feet diameter and complies with full highway standards which may need to be narrowed slightly to be compatible with the future technological limits.

### **11.2.3.4 Tunneling Methods**

Tunnel construction methods sequences, equipment, and systems must be selected considering tunnel size and function, cost and schedule and the full range of geologic and hydrologic conditions, possible impacts on the adjacent structures, compatibility with final ground support, safety, and economy. This assessment focused on tunnel construction by two primary methods, Tunnel Boring Machine (TBM) and Sequential Excavation Method (SEM) approaches. Extensive or lengthy use of the Cut-and-Cover method of tunnel construction was not considered due to the potential significant disruption to the surface improvements and right-of-way requirements. However it is conceivable that even with primary tunnel construction using the TBM or SEM methods, limited segments near the portals – where the depth of the tunnel is shallower – may require the use of cut-and-cover methods.

It is critical that the face of the tunnel excavation and its full perimeter are tightly controlled to minimize ground losses (soil movement toward the tunnel shield) and movements of the overlying ground and ground surface. For these reasons, the primary underground construction methods to be considered for the 710 Tunnel would be Pressure Face Tunnel Boring Machines. Other methods, such as the Sequential Excavation Method (SEM) may also prove effective, and warrant consideration for non-circular cross sections or short reaches for cross-passages and adits (due to the additional construction flexibility offered).

### 11.2.3.5 Fault Crossings

Seismic faults and conditions are not unusual and can be found throughout California and numerous underground transportation facilities have been constructed in the Los Angeles metropolitan area. The major fault crossing within the study area is the Raymond Hill fault. Ground is expected to vary between highly fractured to crushed with seams of clay gouge.

MTA's Metro Red Line tunnels were constructed through the Santa Monica Fault zone. Seismic design for the Santa Monica Fault crossing included an oversized, mined tunnel section to facilitate repair in the event of fault displacement. The mined section was constructed using SEM with shotcrete and lattice girders as final support.

While additional study is required to characterize the fault in the location of the Route 710 tunnel crossing, feasible construction methods for a fault crossing could include SEM using multiple drifts and specialized support, such as ground treatment through grouting, or TBM driven tunnels with specially reinforced segments. The means and methods for the Route 710 tunnel to cross the Raymond Hill fault is area that warrant more comprehensive analysis to ensure public safety is maximized.

## 11.3 Environmental Feasibility

The preliminary environmental analysis conducted for this study was intended to address the likely and potential issues and impacts related to construction and operation of a major highway tunnel upon the adjacent and affected communities and the environment. It was not intended to provide the level of detail of evaluations contained in an environmental document. The focus of the preliminary environmental assessment is to address the potential tunnel issues and impacts to the environment within the study area and to identify any issues or constraints that will preclude additional consideration of the tunnel concept to close the Route 710 Gap.

For more complete discussions regarding the Preliminary Environmental Analysis refer to Chapter 8 of this report. This section summarizes the preliminary level of environmental analysis based upon early assumptions of the project description to support the feasibility study and to identify any potential key issues associated with the feasibility of any tunnel alternative to complete the Route 710 freeway. If it were decided to explore a tunnel option in more detail then the subsequent refinements in project description, alignments, or environmental laws would require a more detailed evaluation of the issues raised under this initial study, with formulation of a comprehensive mitigation strategy.

The Preliminary Environmental Analysis for the conceptual Route 710 tunnel alternatives has considered the existing conditions, the environmental constraints, the potential impacts that could occur, and suggested typical mitigation measures for further examination.

From the environmental perspective, the proposal to complete the Route 710 gap in the freeway system via a highway tunnel appears viable and feasible. The environmental impacts to the following resources may occur: noise, air quality, historic properties, aesthetics, archaeology, hazardous waste, soil disposal, and storm water impacts. However the severity of these impacts can be minimized, eliminated or mitigated. Based upon this preliminary environmental assessment, no insurmountable environmental issues have been identified that would preclude further consideration of the tunnel alternative. However, it is recommended that additional detailed evaluations and analyses be conducted to determine the tunnel alternative including alignment, features and amenities that would be the most environmentally suited to the community and the Route 710 corridor.

The main environmental constraints to the tunnel concept relate to the portal locations, the ventilation shafts, and the potential interchange at Huntington Drive.

During subsequent environmental evaluation or additional conceptual planning for the tunnel alternatives, more detailed evaluations are warranted to identify the most appropriate strategies to minimize, eliminate or mitigate these impacts. It will be necessary to include an active public participation program to review concepts and provide feedback of the various project proposals.

### **11.3.1 Potential Impacts and Mitigation Measures**

This section describes the typical environmental impacts that may occur and the typical types of mitigation that could be used to avoid, minimize or mitigate those impacts.

#### **11.3.1.1 Noise**

##### *During Construction*

Temporary noise barriers can be used to reduce construction noise levels from equipment operating at the surface. Consideration should be given to determine whether permanent noise barriers should be implemented initially if they provide the appropriate level of mitigation of construction activity noise. Construction activities during nighttime and/or weekend hours will be subject to noise level limits based on the existing ambient levels. No significant impacts are expected.

##### *During Operation*

Noise impacts during the actual operation of the tunnel are not anticipated to be above established noise thresholds as methods can be utilized to minimize noise levels. Soundwalls and sound absorptive treatments would be used at the portals to decrease the extent of noise emanating from the portal areas.

Sound attenuators for ventilation fans and tunnel portal jet fans would be used to reduce noise levels to the areas around the ventilation buildings to meet the level permitted by the local noise

ordinance. The ventilation fan buildings have been assumed to be located beneath ground level to reduce impacts.

Additional traffic that would be circulated to surrounding roadways (I-10, SR 134 and I-210) would not result in any increased noise at these locations. The maximum traffic noise would occur at roadway capacity (1950 vehicles/lane/hour) operating at a free flow condition of Level of Service (69 miles per hour). Additional traffic volumes exceeding capacity on these roadways would reduce travel speed effectively reducing noise levels.

### **11.3.1.2 Air Quality**

#### *During Construction*

Typically, project related construction impacts would be localized, and predominant emissions would be nitrogen dioxide, carbon monoxide, sulfur oxides, and diesel particulate matter from diesel powered construction equipment; carbon monoxide emissions from worker vehicles, and PM<sub>10</sub> or dust emissions from vehicles traveling on unpaved surfaces, or as the result of grading and other earthmoving activities.

There could be substantial PM<sub>10</sub> emissions associated with excavation and tunneling activities (grading, excavation, creation of storage piles, loading of material onto haul trucks, etc.). Implementing a fugitive dust program that could include measures such as site wetting and other controls would minimize impacts of construction. Maintenance of construction equipment emissions control systems could also be implemented to reduce construction impacts. Application of these standard measures would reduce construction related air quality impacts to below a level of significance.

#### *During Operation*

Potential impacts of the vehicular emissions would be generated within the proposed tunnel and would be released to the atmosphere through the tunnel's two portals and the ventilation stacks. CO, PM<sub>10</sub>, and DPM are pollutants of concern for this analysis. Particulate matter and diesel particulate matter would be considered because of the diesel vehicles that may travel through the tunnel.

The significance of localized project impacts depends on whether predicted CO and PM<sub>10</sub> levels in the vicinity of the portals would be above or below the NAAQS and whether the projected increases in DPM near the tunnel portals would be above or below the SCAQMD's significant impact threshold.

If air pollutant levels would be found to exceed these standards and thresholds, then the following potential mitigation measures could be considered:

- Raising the height of the ventilation shafts to increase atmospheric dispersion.
- Relocate ventilation shafts away from areas of residential land use.
- Revise the ventilation system to minimize the discharge at the portals.
- Modify the ventilation system at the portal to increase dispersion.

### 11.3.1.3 Historic Properties

#### *During Construction*

Potential impacts to historic properties would occur in relation to ground vibration and settlement during the excavation of the tunnel under historic properties and/or historic districts. This potential impact would be greater with shallower tunnel depths occurring near the portal locations.

If it were decided to proceed with an interchange at Huntington Drive more vibration impact may occur at the Short Line Villa Tract Historic District.

The potential ground vibration impact would be temporary in nature as the tunnel boring machine passed underneath the historic property and/or historic district. Different construction techniques and building protection can be utilized to protect and minimize vibration and settlement to these structures.

#### *During Operation*

The operation of rubber tired vehicles within the tunnel would result in imperceptible ground vibration levels to the historic properties above. No impacts would be expected.

The tunnel portal structures and ventilation buildings and shafts are large-scale structures that could have a major visual and aesthetic impact on the surrounding communities. Aesthetic treatments to the structures themselves, such as decorative architectural features and incorporation of art can be included in the design of the tunnel and associated structures to decrease their visual impacts and increase the aesthetics of their design. Softscape treatments such as landscape buffers, vegetated slopes and walls, and the conversion of remnant parcels into neighborhood parks can help blend the structures into the surrounding area, enhance the overall aesthetics of the surrounding area, and minimize visual impacts.

Architectural and urban designs for the portal structures, ventilation shafts, and surrounding areas should consider context sensitive design; visual quality; safety and operational requirements; security through environmental design; appropriate lighting; architectural treatments; and landscape interfaces. Workshops can be used to address key design issues with stakeholders. A focused community outreach and design process can help establish consensus on key design issues. A comprehensive landscape plan can be developed for integration of the physical structures into the surrounding community. The plan could incorporate features that

meet the goals for aesthetic character and design for the area as established by the community's goals.

Some initial examples of portal and ventilation stack treatments are provided in Chapter 7 to indicate some potential mitigation ideas.

#### **11.3.1.4 Archeological Impacts**

Archaeological sites are not anticipated to be found within the project area.

#### **11.3.1.5 Hazardous Materials/Waste**

If hazardous materials are encountered during Geological boring activities, the cuttings would be properly disposed and the boring would be backfilled with bentonite grout. Any structures that would be demolished as part of construction will also undergo an evaluation for the presence of hazardous materials prior to demolition, in accordance with the ESA process.

Because dewatering activities may be necessitated by the proposed project, groundwater analyses will need to be performed, prior to issuance of the National Pollution Discharge Elimination System (NPDES) dewatering permit, to determine the type and extent of any hazardous materials/waste contamination.

#### **11.3.1.6 Disposal of Soil During Construction**

Another environmental impact relates to the disposal of soil during construction. Using trucks to haul soil to a landfill or other disposal site(s) via the freeway system would also have noise, air quality, and traffic impacts along the haul route. If the Union Pacific railroad spur (near the southern portal location) is used to remove the soil, the associated environmental impacts may be reduced.

#### **11.3.1.7 Storm Water Impacts**

Best management practices (BMPs) would be implemented during construction for stormwater pollution control, in accordance with the National Pollutant Discharge Elimination System (NPDES). The project would need to comply with all Regional Water Quality Control Board's water quality standards and waste discharge requirements and Caltrans Statewide NPDES Storm Water requirements.

The proposed project would not create long-term demand for water and demand for water during construction would be limited. The proposed project would not include any activities that would have long-term effects on local water sources; therefore, additional contribution of runoff water would not exceed the capacity of existing or planned stormwater drainage systems, provide substantial additional sources of polluted runoff, or degrade water quality.



Some issues that may have significant impacts and will be studied at a later project phase include the following:

- Water quality standards or waste discharge requirements
- Depletion of groundwater supplies or interference with groundwater recharge or a lowering of the local groundwater table level
- Alteration of the existing drainage pattern of the site or area, which could result in erosion or siltation or increase the rate or amount of surface runoff which could result in flooding on- or off-site
- Creation or contribution to runoff water which could exceed the capacity of existing or planned storm water drainage systems or provide additional sources of polluted runoff
- Impacts on the physical, chemical, or biological qualities of water quality

## **11.4 Financial Feasibility**

### **11.4.1 Financial Feasibility**

The Route 710 Gap Closure is a project of regional significance. Should the freeway be completed by a four-lane per direction tunnel alternative, this facility will be one of the biggest and longest highway tunnels in the Western Hemisphere. The technical feasibility assessment considered a myriad of tunnel alternatives and optional physical features with costs ranging from approximately \$2.3 billion to \$3.6 billion (2006 dollars). A “representative” tunnel cost estimate of \$3 billion (2006 dollars) was used for the purposes of identifying potential funding sources and developing financial strategies to reflect the range of tunnel alternatives considered.

### **11.4.2 Financial Strategy**

The purpose of developing financial strategies is to assist the Los Angeles County Metropolitan Transportation Authority (MTA) in identifying potential funding sources and funding scenarios for the future implementation of a Tunnel Alternative for the Route 710 Gap Closure.

This Financial Strategy Report provides a starting point for the development of the project’s financial plan. As the Route 710 Tunnel project proceeds through the state and federal environmental and project implementation processes, completion of a comprehensive financial plan will be required. Additionally, since the initial order of magnitude construction cost estimate for the tunnel is \$3 billion (2006 dollars), the Route 710 Tunnel project would fall under the Federal Highway Administration’s (FHWA) Mega Project classification which requires the development of a comprehensive financial plan. Under the FHWA Mega Projects Financial Plan process, project sponsors must submit an Initial Financial Plan that provides information on the immediate and longer term financial implications resulting from implementing the project. Project sponsors must then submit annual updates of the Financial Plan to provide information on actual cost and revenue performance in comparison to initial estimates as well as to update

estimates of future year obligations and expenditures. The annual updates provide information on cost and revenue trends, current and potential funding shortfalls and the financial adjustments necessary to assure completion of the project.

The purpose and need for the Route 710 Gap Closure tunnel alternative provides the basis for identifying potential revenue sources related to accomplishing specific goals and objectives required to enhance mobility and connectivity for people and goods, improve environmental quality, and increase safety and security.

### **11.4.3 Financial Strategy Development**

The financial strategy development process is based on achieving federal, state, regional, and local coordination to identify and secure the financial resources needed to resolve the transportation issues that residents, workers, and visitors to the region experience daily. The process of identifying potential financial strategies for the Route 710 Tunnel began by first defining the magnitude of capital costs. For the purposes of this financial strategy report for the Route 710 tunnel concept, this report uses the current order of magnitude cost estimate of \$3 billion (2006 dollars) to be a representative cost of the tunnel alternatives considered. The technical feasibility assessment considered a myriad of tunnel alternatives and optional physical features with costs ranging from approximately \$2.3 billion to \$3.6 billion (2006 dollars). This \$3 billion tunnel cost estimate is reflective of a tunnel alternative with features that may be deemed acceptable and was selected as a representative cost estimate for the development of the financial strategy report.

Additionally it is important to note that the \$3 billion estimate reflects construction related costs only. Should additional evaluations of the tunnel concept be performed, supplemental efforts should be undertaken to refine the cost estimates and construction methods. Currently, cost estimates have not been developed for the project's land acquisitions, environmental documentation, preliminary and final design, construction management, insurance, and agencies/force account oversight and staff. Further as a result of the significant construction cost of the Huntington Drive interchange, this optional feature is not included in the \$3 billion cost estimate.

Also, the \$3 billion construction cost estimate, as well as revenue estimates from federal, state, regional/local, and user fee sources, all reflect current year/un-inflated dollars (2006 dollars). Two preliminary construction scenarios, each with two starting dates, are being evaluated for the Route 710 Tunnel. The start dates of 2015 and 2023 are assumptions made for the purpose of financial strategies development.

- Construction Scenario 1: TBM – 9 years to complete construction.
- Construction Scenario 2: SEM – 11.5 years to complete construction.

Based on these two scenarios, the \$3 billion (2006 dollar) order of magnitude construction cost estimate is projected to be in the range of \$4.3 to \$5.4 billion year of expenditure dollars for Construction Scenario 1 and in the range of \$4.4 to \$5.5 billion year of expenditure dollars for Construction Scenario 2. At this time, it is assumed that the revenue from the potential funding sources identified in this report would grow at the same rate of inflation as the construction costs.

Based on the \$3 billion (2006 dollars) estimate, a three step process was then used to evaluate, screen, and refine possible funding sources and financial strategies which included: 1) identifying and screening a long list of potential federal, state, regional, and local funding sources; 2) identifying and analyzing potential funding and financing scenarios; and 3) preparing this financial strategies report.

Following the development of the order of magnitude construction cost estimate, potential funding sources, both conventional and innovative, were identified and screened in conjunction with the Study Team and Working Group. The screened funding sources remaining for consideration were then combined into four potential funding strategies. Each financial strategy places different levels of emphasis on the relative share of funding to be provided at the federal, state, regional, and local levels and with regard to the potential for tolling.

#### **11.4.4 Potential Funding Sources**

The array of potential funding sources for the Route 710 Tunnel include federal, state, regional, and local funding sources that could be considered by the MTA and Caltrans. As shown in Tables 1 and 2 of Chapter 10, over 25 federal, state, regional, and local funding sources were identified and screened to a more promising list of 14 potential funding sources. The potential funding sources that were carried forward in the financial scenarios analysis are described in greater detail in the sections below.

##### **11.4.4.1 Federal Sources**

The anticipated Purpose and Need of the Route 710 Gap Closure addresses issues of national and regional significance related to: improving air quality; providing a connection to balance the existing transportation system; linking a major port with inland goods movement, and improving the connection to critical national defense facilities. For addressing these issues, the Route 710 Tunnel should be considered a strong candidate for receipt of federal funding.

The following U.S. Department of Transportation, Federal Highway Administration (U.S. DOT, FHWA) programs were considered as potential funding sources for the Route 710 Tunnel. Federal funding programs are divided into four categories:

- 1) “Core” programs which are formula based meaning each state receives a certain percentage of available funds based on measures such as population, lane-miles of Federal-aid highways, total vehicle-miles traveled on those Federal-aid highways, estimated contributions to the highway account of the highway trust fund; or lane miles. Core programs include:
  - i) National Highway System

- ii) Surface Transportation Program
  - iii) Congestion Mitigation and Air Quality Program
  - iv) Highway Safety Improvements
- 2) Discretionary programs which the overall dollar amount for the program is authorized by Congress and funding is provided either in the form of earmarks or the FHWA decided which projects get the funds based on evaluations. Discretionary programs include:
- i) High Priority Project Earmark
  - ii) Projects of National and Regional Significance
  - iii) National Corridor Infrastructure Improvement Program
  - iv) Transportation Improvement Projects
  - v) Freight Intermodal Distribution Pilot Grant Program
  - vi) Interstate Maintenance Program
  - vii) Bridge Program

#### **11.4.4.2 State Sources**

Four state funding sources were considered as potential funding sources for the Route 710 Tunnel: the Interregional Improvement Program component of the State Transportation Improvement Program (STIP), Grant Anticipation Revenue Vehicle (GARVEE) bonds, proceeds from potential future State infrastructure bonding, and proceeds from the sale of excess right-of-way previously acquired for the Route 710 Gap Closure at-grade alternative. Descriptions and analysis of these programs are provided in Chapter 10.

#### **11.4.4.3 Regional/Local Sources**

Four regional sources were considered as potential funding sources for the Route 710 Tunnel: 1) the STIP Regional Improvement Program (funds distributed to the regional agencies from the State); 2) MTA Call for Projects which allocates discretionary funds to regionally significant projects; 3) Proposition C 25 Percent Funds which provides for transit-related improvements to freeways and state highways; and 4) Future County Sales Tax which would allow MTA to institute an additional transactions and use tax at the rate of 0.5% for 6 1/2 years or less.

#### **11.4.4.4 Tolling**

A financial strategy that merits consideration for funding a portion of the Route 710 Tunnel is toll revenues. Bonds leveraged from anticipated toll revenue could potentially be a component of the funding and financing proposed for the Route 710 Tunnel.

#### **11.4.5 Financial Scenarios**

Seven preliminary financial scenarios were developed based on the funding sources identified in Chapter 10, Section 2. Each financial scenario places different levels of emphasis on federal,

state, regional/local and toll revenue bond funding contributions. Three scenarios assumed the project would not include toll revenue bond proceeds as a funding source and four scenarios assumed the project would include toll revenue bond proceeds. Table 9 summarizes the ranges of potential federal, state, regional/local and toll revenue bond funding comprising the seven scenarios. The target percentages and equivalent funding contributions shown in the following assume a working construction cost estimate of \$3.0 billion (2006 dollars). However, as stated earlier depending on which construction scenario is chosen and when construction begins, the \$3 billion (2006 dollar) order of magnitude construction cost estimate is projected to be in the range of \$4.3 to \$5.5 billion year of expenditure dollars. At this stage of project development, it is assumed that revenue from the sources identified in the following sections would grow at the same rate of inflation as the construction costs. As a result the target percent shares from the different funding sources would be maintained as shown in the figures below. Finally, for the purpose of this analysis, the cost curves for the seven financial scenarios reflect the 11.5 year construction schedule of Construction Scenario 2 described in Chapter 10, Section 1.2.

## 11.5 Summary

### 11.5.1 Summary Points

- Traffic analysis indicates that 4 lanes would be required in each direction, with or without Trucks included.
- The possibility of an interchange at Huntington Drive would further attract traffic in the Gap and on Huntington Drive itself
- Traffic modeling reveals that generally, the completion of the Route 710 freeway would benefit and relieve traffic impacts on some adjacent freeways and arterials in proximity to the study area.
- Geologic conditions appear favorable to construct a tunneled solution
- Feasible Tunnel configurations, within current technology are possible
- Identified Environmental issues associated with construction and operation of the main tunnel are initially assessed to be solvable. However, more issues arise in the event that an interchange at Huntington Drive is included.
- Construction Cost Estimates in the region of \$3 billion make this a major infrastructure improvement, which would require special funding initiatives.
- The preliminary technical findings indicate that a tunnel is a viable solution and warrants to be advanced to the next more comprehensive and detailed evaluations.